

CK9,5-ED-120,00F AG - Crimp contact



1682071

<https://www.phoenixcontact.com/us/products/1682071>

Please be informed that the data shown in this PDF document is generated from our online catalog. Please find the complete data in the user documentation. Our general terms of use for downloads are valid.



Crimp contact, series: HC-M-...-120, Socket, turned, contact diameter: 9.5 mm, rated current: 300 A, connection cross section: 120 mm² ... 120 mm², AWG 4/0...4/0, contact material: Cu alloy

Commercial data

Item number	1682071
Packing unit	1 pc
Minimum order quantity	1 pc
Sales key	BF65
Product key	AF7AIH
GTIN	4067923237001
Weight per piece (including packing)	55.8 g
Weight per piece (excluding packing)	55 g
Customs tariff number	85366990
Country of origin	DE

CK9,5-ED-120,00F AG - Crimp contact



1682071

<https://www.phoenixcontact.com/us/products/1682071>

Technical data

Notes

General	HC-M-...-120 contact carrier
Assembly note	The quality of a crimp connection is determined by DIN EN 60352-2.
Assembly note	The contacts are qualified for crimping dies in accordance with DIN 46235. Klauke, for example, offers an appropriate tool: Crimping dies from the HD13 series are required for the EK12042 battery-powered hydraulic crimping pliers. Due to a wider crimping process, only one compression is required.
Assembly note	<p>Note on crimp connection technology:</p> <p>For flexible wires only. The specified conductor cross-sections refer to the nominal cross-section of the cable used.</p> <p>The wiring space of the crimp connection technology is designed for fine-stranded cables in accordance with VDE 0295 Class 5. Deviating cable structures (e.g., Class 1.2 and 6 or AWG cables) should be checked before use.</p>

Product properties

Product type	Crimp contact
Series	HC-M-...-120
Contact material type	turned

Connection data

Connection technology

Contact connection type	Socket
Connection method	Crimp connection

Conductor connection

Stripping length	22.5 mm
Connection cross section	120 mm ² ... 120 mm ²
Connection cross section AWG	4/0 ... 4/0

Material specifications

Material Contact	Cu alloy (lead-free)
Material Contact surface	Ag

Dimensions

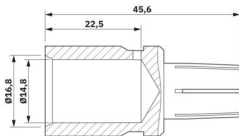
Dimensional drawing	
Length [l]	45.6 mm

CK9,5-ED-120,00F AG - Crimp contact



1682071

<https://www.phoenixcontact.com/us/products/1682071>

Diameter (Contact diameter)	9.5 mm
-----------------------------	--------

Electrical properties

Rated current	300 A ()
---------------	----------

Mechanical properties

Mechanical data

Insertion/withdrawal cycles	≥ 500
-----------------------------	-------

Environmental and real-life conditions

Ambient conditions

Ambient temperature (operation)	-40 °C ... 125 °C
---------------------------------	-------------------

CK9,5-ED-120,00F AG - Crimp contact



1682071

<https://www.phoenixcontact.com/us/products/1682071>

Drawings

Dimensional drawing

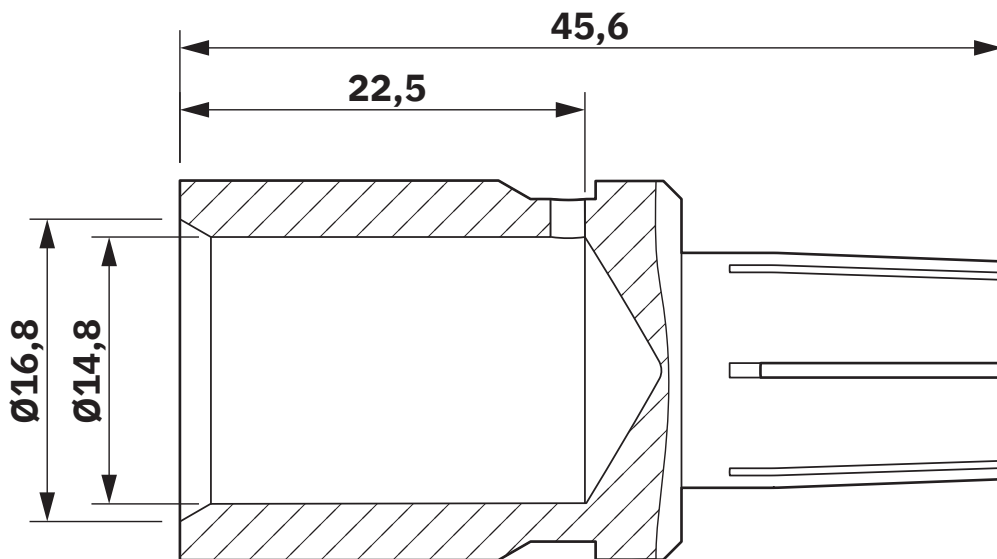

Dimensional drawing

CK9,5-ED-120,00F AG - Crimp contact



1682071

<https://www.phoenixcontact.com/us/products/1682071>

Classifications

ECLASS

ECLASS-13.0	27440204
ECLASS-15.0	27440204

ETIM

ETIM 10.0	EC000796
-----------	----------

CK9,5-ED-120,00F AG - Crimp contact



1682071

<https://www.phoenixcontact.com/us/products/1682071>

Environmental product compliance

EU RoHS

Fulfills EU RoHS substance requirements	Yes, No exemptions
---	--------------------

China RoHS

Environment friendly use period (EFUP)	EFUP-E
	No hazardous substances above the limits

EU REACH SVHC

REACH candidate substance (CAS No.)	No substance above 0.1 wt%
-------------------------------------	----------------------------

Phoenix Contact 2026 © - all rights reserved
<https://www.phoenixcontact.com>

Phoenix Contact USA
586 Fulling Mill Road
Middletown, PA 17057, United States
(+717) 944-1300
info@phoenixcon.com