

SACB-HC-B10-SMQ-8/B - Sensor distributor



1678525

<https://www.phoenixcontact.com/us/products/1678525>

Please be informed that the data shown in this PDF document is generated from our online catalog. Please find the complete data in the user documentation. Our general terms of use for downloads are valid.



Sensor distributor with HEAVYCON box mounting base B10, with double-locking latch, height 74 mm, with HC-B10-EBUC assembled with CK2,5-ED-0,5 ST AG and eight SACC-E-M12MS-5CON-PG9/05 inserted in the side walls

Commercial data

Item number	1678525
Packing unit	1 pc
Minimum order quantity	1 pc
Product key	AF7AEX
GTIN	4017918367039
Weight per piece (including packing)	499.2 g
Weight per piece (excluding packing)	499.2 g
Country of origin	DE

1678525

<https://www.phoenixcontact.com/us/products/1678525>

Technical data

Product properties

Number of positions	10
Number of slots	8

Material specifications

Material Housing	Die-cast aluminum
Contact material	Copper alloy
Contact surface material	Ag (CK2,5-ED-0,5ST AG) / Au (SACC-E_M12FS-5CON-PG9/05)
Contact carrier material	PA

Environmental and real-life conditions

Ambient conditions

Degree of protection	IP65
Ambient temperature (operation)	-25 °C ... 85 °C

SACB-HC-B10-SMQ-8/B - Sensor distributor



1678525

<https://www.phoenixcontact.com/us/products/1678525>

Drawings

Dimensional drawing

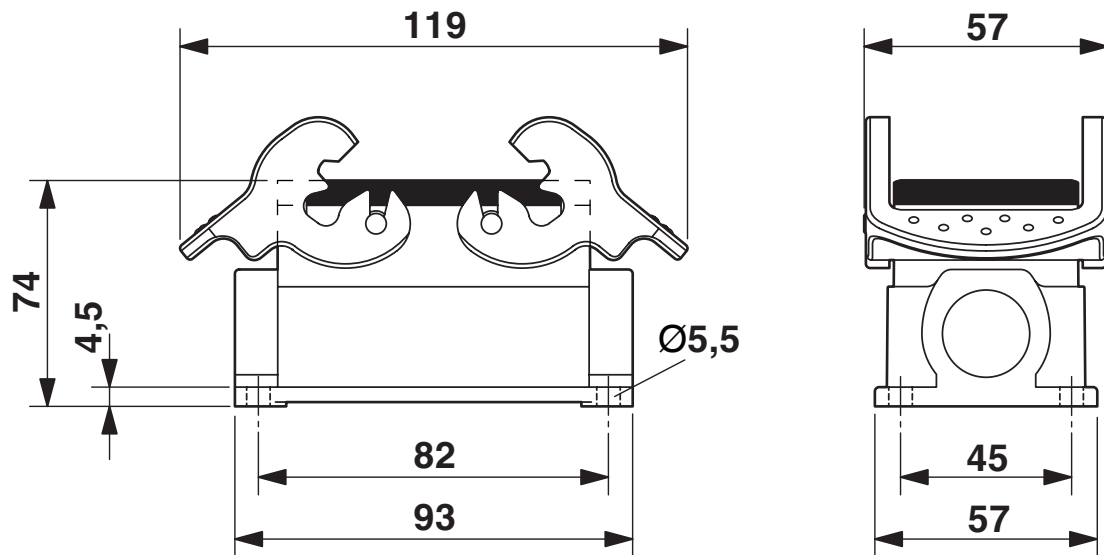

Dimensional drawing

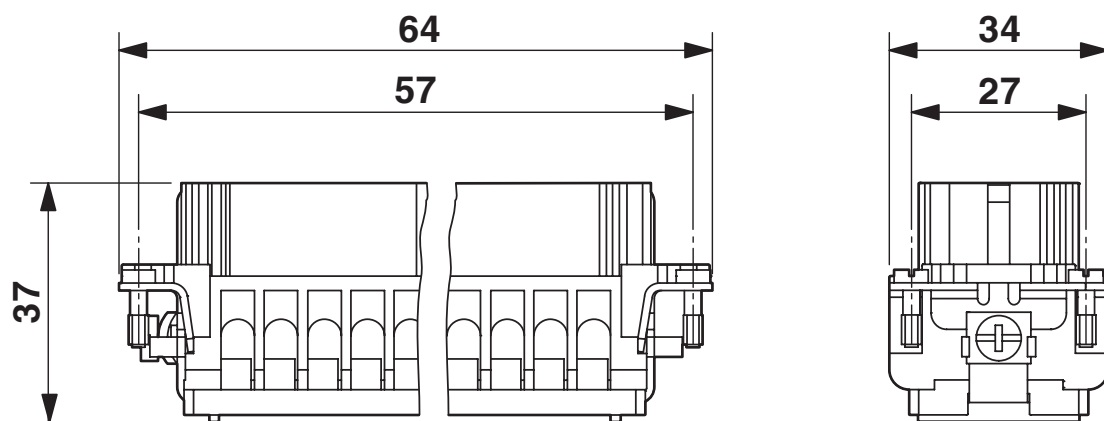

Female insert

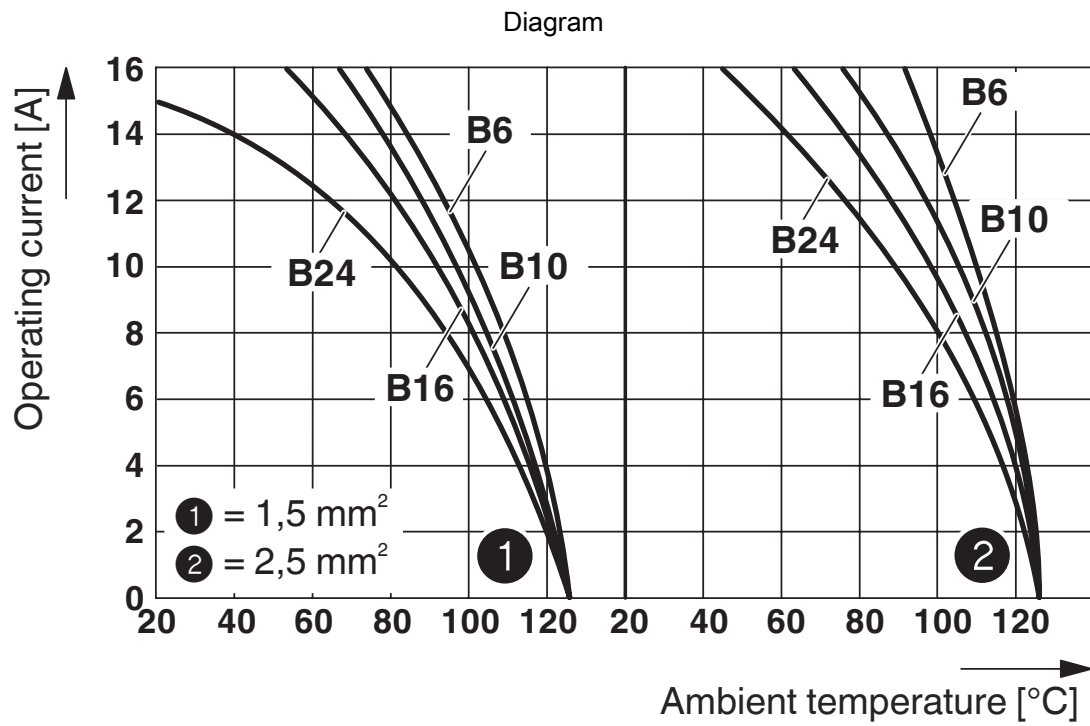

Derating diagram HC-B10-EBUC

SACB-HC-B10-SMQ-8/B - Sensor distributor



1678525

<https://www.phoenixcontact.com/us/products/1678525>

Circuit diagram

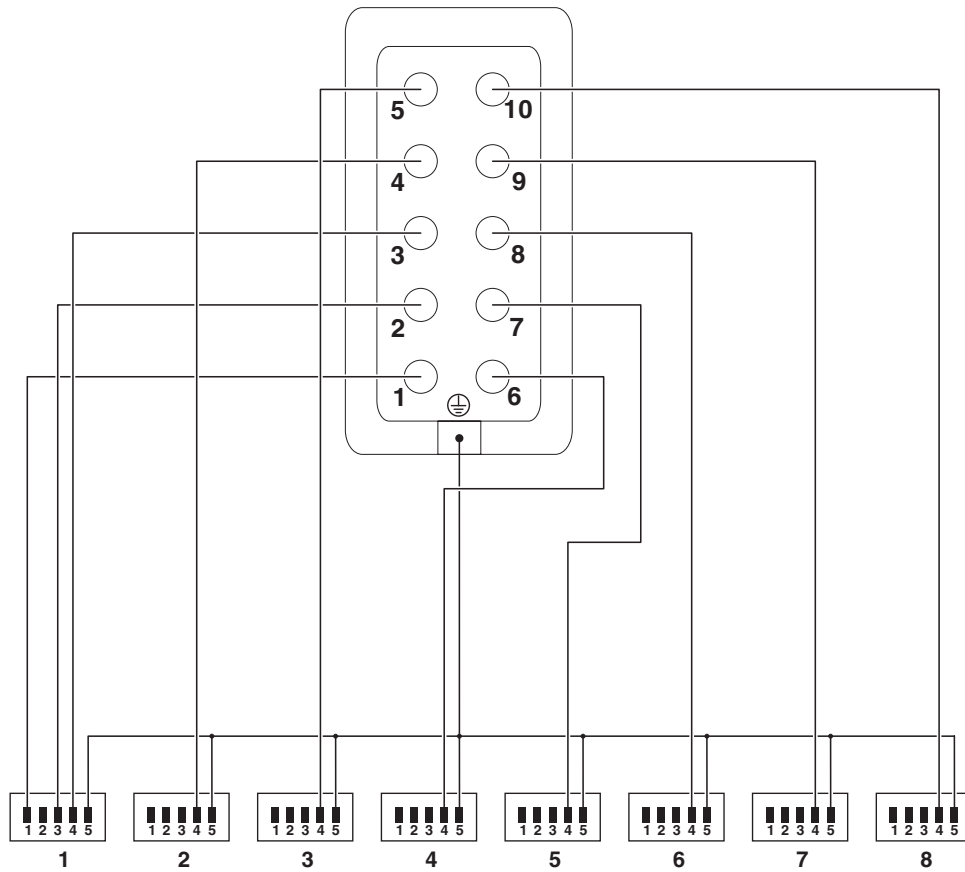

Circuit diagram

SACB-HC-B10-SMQ-8/B - Sensor distributor



1678525

<https://www.phoenixcontact.com/us/products/1678525>

Classifications

UNSPSC

UNSPSC 21.0	31261501
-------------	----------

1678525

<https://www.phoenixcontact.com/us/products/1678525>

Environmental product compliance

EU RoHS

Fulfills EU RoHS substance requirements	Yes
Exemption	6(c)

China RoHS

Environment friendly use period (EFUP)	EFUP-50
	An article-related China RoHS declaration table can be found in the download area for the respective article under "Manufacturer declaration". For all articles with EFUP-E, no China RoHS declaration table issued and required.

EU REACH SVHC

REACH candidate substance (CAS No.)	Lead(CAS: 7439-92-1)
-------------------------------------	----------------------

Phoenix Contact 2026 © - all rights reserved
<https://www.phoenixcontact.com>

Phoenix Contact USA
586 Fulling Mill Road
Middletown, PA 17057, United States
(+717) 944-1300
info@phoenixcon.com