

# HC-B 48-SML-100/O2PG29 - Housing



1675120

<https://www.phoenixcontact.com/us/products/1675120>

Please be informed that the data shown in this PDF document is generated from our online catalog. Please find the complete data in the user documentation. Our general terms of use for downloads are valid.

Box mounting base, with single locking latch, height: 100 mm, with glands, 2 x Pg29



## Commercial data

Item number	1675120
Packing unit	1 pc
Note	Made to order (non-returnable)
Sales key	BF55
Product key	AF7AAC
GTIN	4017918149888
Weight per piece (including packing)	1,250.4 g
Weight per piece (excluding packing)	1.187 g
Customs tariff number	85389099
Country of origin	DE

# HC-B 48-SML-100/O2PG29 - Housing

1675120

<https://www.phoenixcontact.com/us/products/1675120>

## Technical data

### Product properties

Product type	Housing with locking latch
Housing type	Surface mounting housing
Application	Standard
Type	B48
No. of cable outlets	2
Type of the screw connection	2x Pg29
Cable outlet	lateral
Pg screw connection	none

### Dimensions

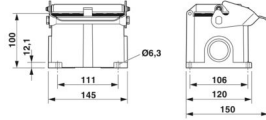
Dimensional drawing	
Width	120 mm
Height	100 mm
Length	145 mm

### Material specifications

Seal material	NBR
Housing material	Die-cast aluminum
Housing surface material	Powder-coated, gray
Locking latch material	Steel, galvanized

### Mechanical properties

#### Mechanical data

Type of the screw connection	2x Pg29
Locking type	Latch

### Mounting

Assembly note	For half and full screw connections
---------------	-------------------------------------

### Environmental and real-life conditions

#### Ambient conditions

Degree of protection	IP65
Ambient temperature (operation)	-40 °C ... 125 °C

# HC-B 48-SML-100/O2PG29 - Housing



1675120

<https://www.phoenixcontact.com/us/products/1675120>

## Drawings

Dimensional drawing

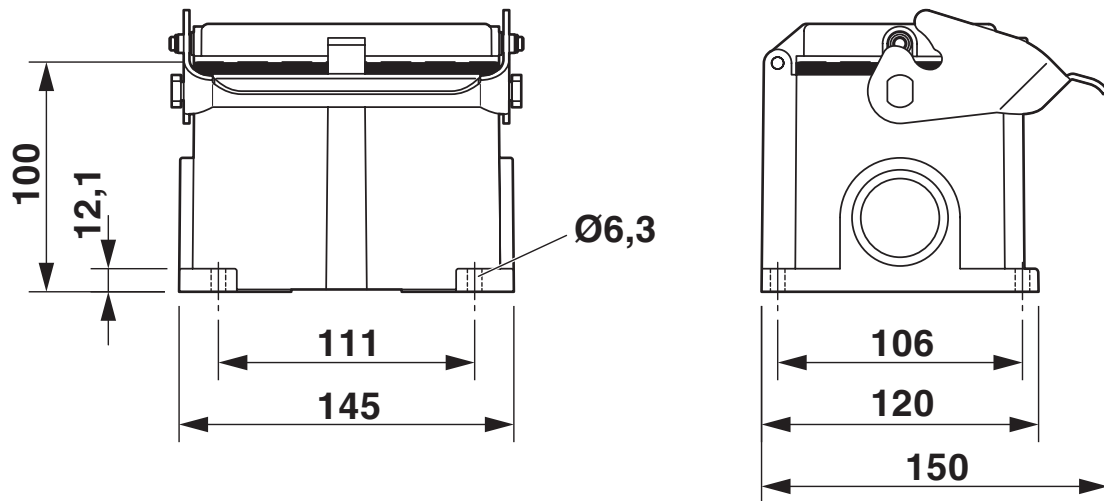

Dimensional drawing

# HC-B 48-SML-100/O2PG29 - Housing



1675120

<https://www.phoenixcontact.com/us/products/1675120>

## Classifications

### ECLASS

ECLASS-13.0	27440202
ECLASS-15.0	27440202

### UNSPSC

UNSPSC 21.0	31261501
-------------	----------

# HC-B 48-SML-100/O2PG29 - Housing



1675120

<https://www.phoenixcontact.com/us/products/1675120>

## Environmental product compliance

### EU RoHS

Fulfills EU RoHS substance requirements	Yes, No exemptions
---	--------------------

### China RoHS

Environment friendly use period (EFUP)	EFUP-E
	No hazardous substances above the limits

### EU REACH SVHC

REACH candidate substance (CAS No.)	No substance above 0.1 wt%
-------------------------------------	----------------------------

Phoenix Contact 2026 © - all rights reserved  
<https://www.phoenixcontact.com>

Phoenix Contact USA  
586 Fulling Mill Road  
Middletown, PA 17057, United States  
(+717) 944-1300  
[info@phoenixcon.com](mailto:info@phoenixcon.com)