

CK2,5-ED-0,5BU AU - Crimp contact



1674859

<https://www.phoenixcontact.com/us/products/1674859>

Please be informed that the data shown in this PDF document is generated from our online catalog. Please find the complete data in the user documentation. Our general terms of use for downloads are valid.



Crimp contact, series: HC-M-06, Socket, turned, contact diameter: 2.5 mm, rated current: 16 A, connection cross section: 0.5 mm² ... 0.5 mm², AWG 20...20, contact material: Cu alloy

Commercial data

Item number	1674859
Packing unit	100 pc
Minimum order quantity	100 pc
Sales key	BF65
Product key	AF7AID
GTIN	4017918135553
Weight per piece (including packing)	1.623 g
Weight per piece (excluding packing)	1.305 g
Customs tariff number	85366990
Country of origin	DE

CK2,5-ED-0,5BU AU - Crimp contact



1674859

<https://www.phoenixcontact.com/us/products/1674859>

Technical data

Notes

Notes on the product family	for HC-M-06..., HC-M-HV-, HC-M-08-, HC-M-20-, HC-A..., HC-B.., HC-BB..., HC-BBB..., and HC-HV contact carriers
Assembly note	The quality of a crimp connection is determined by DIN EN 60352-2.
Assembly note	For voltages less than 5 V and currents less than 5 mA, gold-plated contacts are recommended.
Assembly note	<p>Note on crimp connection technology:</p> <p>For flexible wires only. The specified conductor cross-sections refer to the nominal cross-section of the cable used.</p> <p>The wiring space of the crimp connection technology is designed for fine-stranded cables in accordance with VDE 0295 Class 5. Deviating cable structures (e.g., Class 1.2 and 6 or AWG cables) should be checked before use.</p>

Product properties

Product type	Crimp contact
Series	HC-M-06
	HC-M-HV
	HC-M-08
	HC-A
	HC-BB
	HC-B
	HC-HV
	HC-M-20
	HC-K
	HC-BBB
	HC-Q
	HC-COM
HC-M-EMV	
Contact material type	turned

Connection data

Connection technology

Contact connection type	Socket
Connection method	Crimp connection

Conductor connection

Stripping length	7.5 mm (9.5 mm at HC-M-HV...)
Connection cross section	0.5 mm ² ... 0.5 mm ²
Connection cross section AWG	20 ... 20

Material specifications

CK2,5-ED-0,5BU AU - Crimp contact



1674859

<https://www.phoenixcontact.com/us/products/1674859>

Material Contact	Cu alloy
Material Contact surface	Au

Dimensions

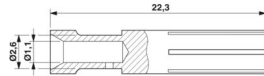
Dimensional drawing	
Diameter (Contact diameter)	2.5 mm

Electrical properties

Rated current	16 A (Take into account the derating of the contact insert used. The rated current corresponds to the maximum possible connection cross-section.)
---------------	--

Mechanical properties

Mechanical data

Insertion/withdrawal cycles	≥ 500
-----------------------------	-------

Environmental and real-life conditions

Ambient conditions

Ambient temperature (operation)	-40 °C ... 125 °C
---------------------------------	-------------------

CK2,5-ED-0,5BU AU - Crimp contact

1674859

<https://www.phoenixcontact.com/us/products/1674859>



Drawings

Dimensional drawing

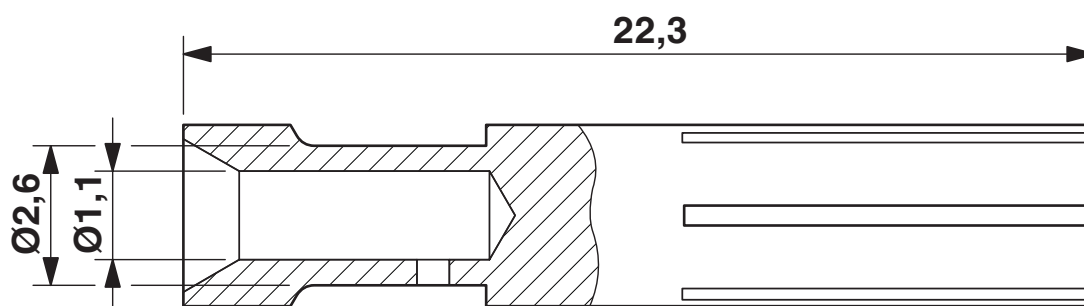

Dimensional drawing

CK2,5-ED-0,5BU AU - Crimp contact



1674859

<https://www.phoenixcontact.com/us/products/1674859>

Approvals

To download certificates, visit the product detail page: <https://www.phoenixcontact.com/us/products/1674859>



EAC

Approval ID: RU C-DE.AI30.B.01102

CK2,5-ED-0,5BU AU - Crimp contact



1674859

<https://www.phoenixcontact.com/us/products/1674859>

Classifications

ECLASS

ECLASS-13.0	27440204
ECLASS-15.0	27440204

ETIM

ETIM 10.0	EC000796
-----------	----------

UNSPSC

UNSPSC 21.0	39121500
-------------	----------

CK2,5-ED-0,5BU AU - Crimp contact



1674859

<https://www.phoenixcontact.com/us/products/1674859>

Environmental product compliance

EU RoHS

Fulfills EU RoHS substance requirements	Yes, No exemptions
---	--------------------

China RoHS

Environment friendly use period (EFUP)	EFUP-E
	No hazardous substances above the limits

EU REACH SVHC

REACH candidate substance (CAS No.)	No substance above 0.1 wt%
-------------------------------------	----------------------------

Phoenix Contact 2026 © - all rights reserved
<https://www.phoenixcontact.com>

Phoenix Contact USA
586 Fulling Mill Road
Middletown, PA 17057, United States
(+717) 944-1300
info@phoenixcon.com