

# CK1,6-ED-0,50BU AU - Crimp contact



1674480

<https://www.phoenixcontact.com/us/products/1674480>

Please be informed that the data shown in this PDF document is generated from our online catalog. Please find the complete data in the user documentation. Our general terms of use for downloads are valid.



Crimp contact, series: HC-M-12, Socket, turned, contact diameter: 1.6 mm, rated current: 10 A, connection cross section: 0.5 mm<sup>2</sup> ... 0.5 mm<sup>2</sup>, AWG 20...20, contact material: Cu alloy

## Commercial data

Item number	1674480
Packing unit	100 pc
Minimum order quantity	100 pc
Sales key	BF65
Product key	AF7AIA
GTIN	4017918135386
Weight per piece (including packing)	714 MGM
Weight per piece (excluding packing)	714 MGM
Customs tariff number	85366990
Country of origin	DE

# CK1,6-ED-0,50BU AU - Crimp contact

1674480

<https://www.phoenixcontact.com/us/products/1674480>

## Technical data

### Product properties

Product type	Crimp contact
Series	HC-M-12
	HC-M-EMV
	HC-D
	HC-DD
	VC-D
	HC-M-03/04
	HC-M-17
	HC-K
	HC-Q
	HC-COM
	HC-M-42
	HC-M-08-MBIT
Contact material type	turned

### Connection data

#### Connection technology

Contact connection type	Socket
Connection method	Crimp connection

#### Conductor connection

Stripping length	8 mm
Connection cross section	0.5 mm <sup>2</sup> ... 0.5 mm <sup>2</sup>
Connection cross section AWG	20 ... 20

### Material specifications

Material Contact	Cu alloy
Material Contact surface	Au

### Dimensions

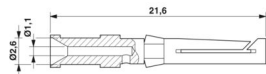
Dimensional drawing	
Diameter (Contact diameter)	1.6 mm

### Electrical properties

Rated current	10 A (Take into account the derating of the contact insert used. The rated current corresponds to the maximum possible connection cross-section.)
---------------	---

### Mechanical properties

# CK1,6-ED-0,50BU AU - Crimp contact



1674480

<https://www.phoenixcontact.com/us/products/1674480>

## Mechanical data

Insertion/withdrawal cycles	≥ 500
-----------------------------	-------

## Environmental and real-life conditions

### Ambient conditions

Ambient temperature (operation)	-40 °C ... 125 °C
---------------------------------	-------------------

# CK1,6-ED-0,50BU AU - Crimp contact



1674480

<https://www.phoenixcontact.com/us/products/1674480>

## Drawings

Dimensional drawing

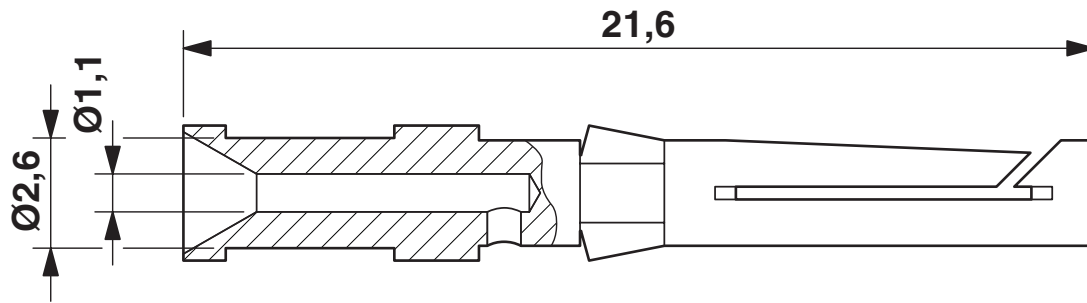

Dimensional drawing

# CK1,6-ED-0,50BU AU - Crimp contact



1674480

<https://www.phoenixcontact.com/us/products/1674480>

## Approvals

To download certificates, visit the product detail page: <https://www.phoenixcontact.com/us/products/1674480>



**EAC**

Approval ID: RU C-DE.AI30.B.01102

# CK1,6-ED-0,50BU AU - Crimp contact



1674480

<https://www.phoenixcontact.com/us/products/1674480>

## Classifications

### ECLASS

ECLASS-13.0	27440204
ECLASS-15.0	27440204

### ETIM

ETIM 10.0	EC000796
-----------	----------

### UNSPSC

UNSPSC 21.0	39121500
-------------	----------

# CK1,6-ED-0,50BU AU - Crimp contact



1674480

<https://www.phoenixcontact.com/us/products/1674480>

## Environmental product compliance

### EU RoHS

Fulfills EU RoHS substance requirements	Yes, No exemptions
---	--------------------

### China RoHS

Environment friendly use period (EFUP)	EFUP-50
	An article-related China RoHS declaration table can be found in the download area for the respective article under "Manufacturer declaration". For all articles with EFUP-E, no China RoHS declaration table issued and required.

### EU REACH SVHC

REACH candidate substance (CAS No.)	No substance above 0.1 wt%
-------------------------------------	----------------------------

### EF3.1 Climate Change

CO2e kg	0.19 kg CO2e
---------	--------------

Phoenix Contact 2026 © - all rights reserved  
<https://www.phoenixcontact.com>

Phoenix Contact USA  
586 Fulling Mill Road  
Middletown, PA 17057, United States  
(+717) 944-1300  
[info@phoenixcon.com](mailto:info@phoenixcon.com)