

CK1,6-ED-0,75BU AU - Crimp contact



1672440

<https://www.phoenixcontact.com/us/products/1672440>

Please be informed that the data shown in this PDF document is generated from our online catalog. Please find the complete data in the user documentation. Our general terms of use for downloads are valid.



Crimp contact, series: HC-M-12, Socket, turned, contact diameter: 1.6 mm, rated current: 10 A, connection cross section: 0.75 mm² ... 0.75 mm², AWG 18...18, contact material: Cu alloy

Commercial data

Item number	1672440
Packing unit	100 pc
Minimum order quantity	100 pc
Sales key	BF65
Product key	AF7AIA
GTIN	4017918135348
Weight per piece (including packing)	0.69 g
Weight per piece (excluding packing)	0.67 g
Customs tariff number	85366990
Country of origin	DE

CK1,6-ED-0,75BU AU - Crimp contact



1672440

<https://www.phoenixcontact.com/us/products/1672440>

Technical data

Notes

Note on application	for HC-M-12, HC-M-17, HC-M-03/04, HC-M-EMV, HC-D, HC-DD, HC-Q, and VC-D contact carriers
Note on application	The quality of a crimp connection is determined by DIN EN 60352-2.
Notes on the product family	For voltages less than 5 V and currents less than 5 mA, gold-plated contacts are recommended.
Notes on connection	<p>Note on crimp connection technology:</p> <p>For flexible wires only. The specified conductor cross-sections refer to the nominal cross-section of the cable used.</p> <p>The wiring space of the crimp connection technology is designed for fine-stranded cables in accordance with VDE 0295 Class 5. Deviating cable structures (e.g., Class 1.2 and 6 or AWG cables) should be checked before use.</p>

Product properties

Product type	Crimp contact
Series	HC-M-12
	HC-M-EMV
	HC-D
	HC-DD
	VC-D
	HC-M-03/04
	HC-M-17
	HC-K
	HC-Q
	HC-COM
HC-M-42	
HC-M-08-MBIT	
Contact material type	turned

Connection data

Connection technology	
Contact connection type	Socket
Connection method	Crimp connection
Conductor connection	
Stripping length	8 mm
Connection cross section	0.75 mm ² ... 0.75 mm ²
Connection cross section AWG	18 ... 18

Material specifications

Material Contact	Cu alloy
------------------	----------

CK1,6-ED-0,75BU AU - Crimp contact



1672440

<https://www.phoenixcontact.com/us/products/1672440>

Material Contact surface	Au
--------------------------	----

Dimensions

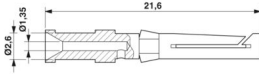
Dimensional drawing	
Diameter (Contact diameter)	1.6 mm

Electrical properties

Rated current	10 A (Take into account the derating of the contact insert used. The rated current corresponds to the maximum possible connection cross-section.)
---------------	---

Mechanical properties

Mechanical data

Insertion/withdrawal cycles	≥ 500
-----------------------------	-------

Environmental and real-life conditions

Ambient conditions

Ambient temperature (operation)	-40 °C ... 125 °C
---------------------------------	-------------------

CK1,6-ED-0,75BU AU - Crimp contact



1672440

<https://www.phoenixcontact.com/us/products/1672440>

Drawings

Dimensional drawing

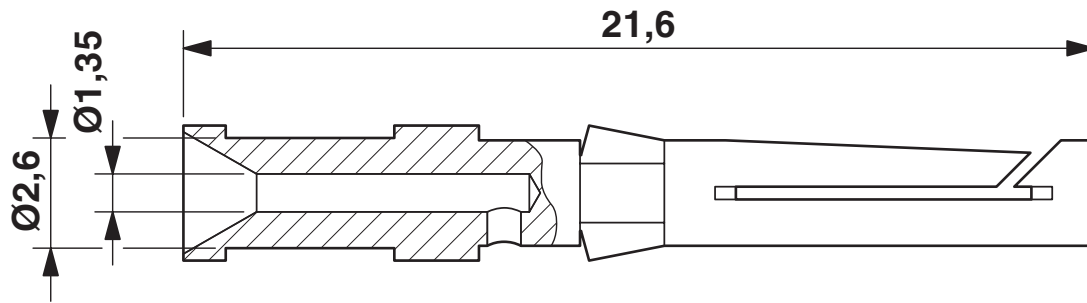

Dimensional drawing

CK1,6-ED-0,75BU AU - Crimp contact



1672440

<https://www.phoenixcontact.com/us/products/1672440>

Approvals

To download certificates, visit the product detail page: <https://www.phoenixcontact.com/us/products/1672440>



EAC

Approval ID: RU C-DE.AI30.B.01102

CK1,6-ED-0,75BU AU - Crimp contact



1672440

<https://www.phoenixcontact.com/us/products/1672440>

Classifications

ECLASS

ECLASS-13.0	27440204
ECLASS-15.0	27440204

ETIM

ETIM 10.0	EC000796
-----------	----------

UNSPSC

UNSPSC 21.0	39121500
-------------	----------

CK1,6-ED-0,75BU AU - Crimp contact



1672440

<https://www.phoenixcontact.com/us/products/1672440>

Environmental product compliance

EU RoHS

Fulfills EU RoHS substance requirements	Yes, No exemptions
---	--------------------

China RoHS

Environment friendly use period (EFUP)	EFUP-50
	An article-related China RoHS declaration table can be found in the download area for the respective article under "Manufacturer declaration". For all articles with EFUP-E, no China RoHS declaration table issued and required.

EU REACH SVHC

REACH candidate substance (CAS No.)	No substance above 0.1 wt%
-------------------------------------	----------------------------

EF3.1 Climate Change

CO2e kg	0.207 kg CO2e
---------	---------------

Phoenix Contact 2026 © - all rights reserved
<https://www.phoenixcontact.com>

Phoenix Contact USA
586 Fulling Mill Road
Middletown, PA 17057, United States
(+717) 944-1300
info@phoenixcon.com