

SACB-8/ 8-L-SC - Distributor box



1671247

<https://www.phoenixcontact.com/us/products/1671247>

Please be informed that the data shown in this PDF document is generated from our online catalog. Please find the complete data in the user documentation. Our general terms of use for downloads are valid.



Distributor box, connection method: M12 socket Plastic, number of slots: 8, number of positions: 4, coding: A, slot assignment: single, status display: yes, PNP; master cable connection: Spring-cage connection 180°, shielding: no

Your advantages

- Safety in the field, thanks to robust housing and high degree of protection
- Convenient: increased machine availability thanks to quick and easy diagnostics
- Flexible: distributor box with connector hood for on-site assembly

Commercial data

Item number	1671247
Packing unit	1 pc
Note	Made to order (non-returnable)
Sales key	NULL
Product key	AF3CBC
GTIN	4017918135096
Weight per piece (including packing)	141.3 g
Weight per piece (excluding packing)	140.6 g
Customs tariff number	85444290
Country of origin	PL

SACB-8/ 8-L-SC - Distributor box



1671247

<https://www.phoenixcontact.com/us/products/1671247>

Technical data

Product properties

Product type	Distributor box
Number of positions	4
Number of slots	8
Coding	A
LED	yes

System properties

Local diagnostics

Monitored function	Supply voltage per module
Optical representation	Green LED

Electrical properties

Max. operating voltage U_{max}	30 V DC
Local diagnostics	Supply voltage per module Green LED
	Status display I/O Yellow LED
Nominal voltage U_N	24 V DC
Rated current, total	12 A
Max. current carrying capacity per path	2 A
Current carrying capacity per slot	4 A

Connection data

Conductor connection

Sensor/actuator connection system	M12 socket
Conductor cross-section Flexible signal line	0.14 mm ² ... 1 mm ²
Conductor cross-section Flexible power supply	0.2 mm ² ... 1.5 mm ²
Connection cross section AWG Flexible signal line	26 ... 17
Connection cross section AWG Flexible power supply	24 ... 16
Stripping length Signal line	10 mm
Tightening torque slot sensor/actuator cable	0.4 Nm
Tightening torque, union nut	2.5 Nm

Connection assignment

Slot/position = Wire color or connection	1 / 4 (A) = 1 / 4
	2 / 4 (A) = 2 / 4
	3 / 4 (A) = 3 / 4
	4 / 4 (A) = 4 / 4
	5 / 4 (A) = 5 / 4
	6 / 4 (A) = 6 / 4
	7 / 4 (A) = 7 / 4
	8 / 4 (A) = 8 / 4

SACB-8/ 8-L-SC - Distributor box

1671247

<https://www.phoenixcontact.com/us/products/1671247>

	1-8 / 1 (+ 24 V) = U _N
	1-8 / 3 (0 V) = 0 V
	1-8 / 5 (PE) = PE

Signaling

Status display present	yes
------------------------	-----

Dimensions

Dimensional drawing	
Width	54 mm
Height	32 mm
Length	155 mm

Material specifications

Material Threaded sleeve	PA
Material Housing	PA
Flammability rating according to UL 94	V0
Seal material O-ring	NBR
Contact material	CuSn
Contact surface material	Ni/Au
Contact carrier material	PA
Material of contact, master cable side	CuZn
Material of the contact carrier on the master cable side	PA 6.6 V0
Material of contact surface, master cable side	NiSn

Cable/line

External cable diameter	6.5 mm ... 9.5 mm
Connection method	Spring-cage connection

Environmental and real-life conditions

Ambient conditions

Degree of protection	IP65
	IP67
Ambient temperature (operation)	-25 °C ... 75 °C

SACB-8/ 8-L-SC - Distributor box



1671247

<https://www.phoenixcontact.com/us/products/1671247>

Drawings

Dimensional drawing

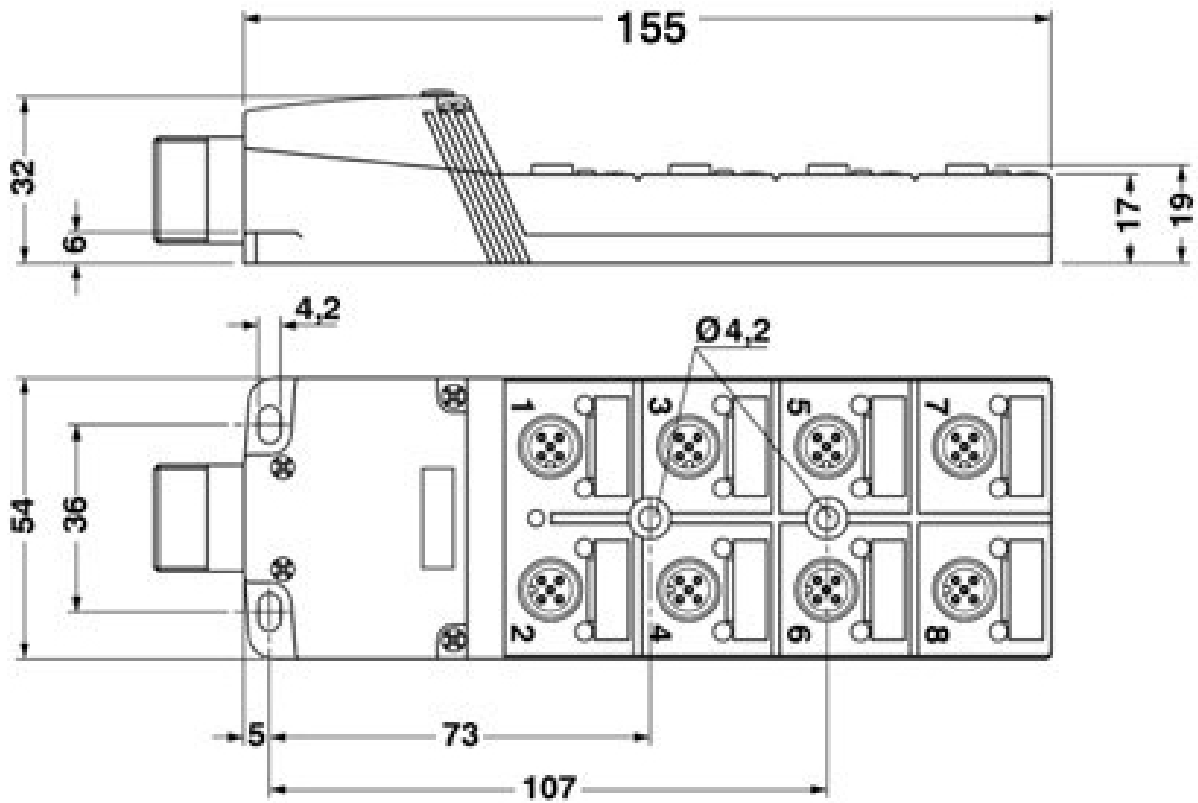

SACB-8/ 8-L-SC - Distributor box

1671247

<https://www.phoenixcontact.com/us/products/1671247>

Schematic diagram

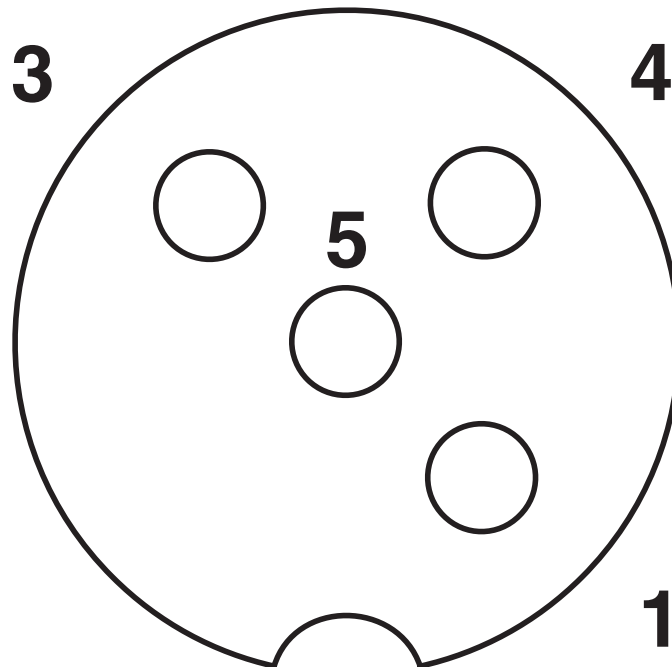

M12 slot, socket, 4-pos.

Circuit diagram

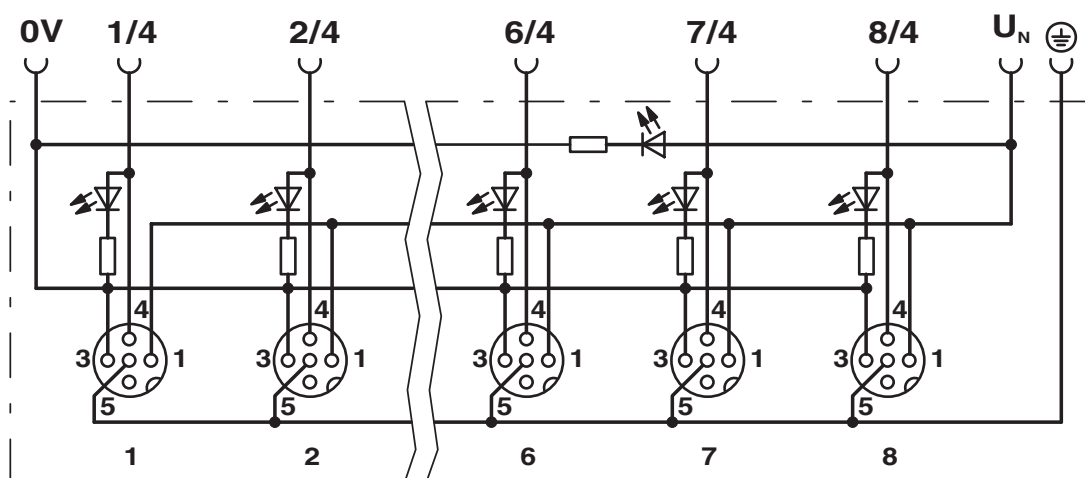

SACB-8/ 8-L-SC - Distributor box



1671247

<https://www.phoenixcontact.com/us/products/1671247>

Classifications

ECLASS

ECLASS-13.0	27440111
ECLASS-15.0	27440111

SACB-8/ 8-L-SC - Distributor box



1671247

<https://www.phoenixcontact.com/us/products/1671247>

Environmental product compliance

EU REACH SVHC

REACH candidate substance (CAS No.)	No substance above 0.1 wt%
-------------------------------------	----------------------------

Phoenix Contact 2026 © - all rights reserved

<https://www.phoenixcontact.com>

Phoenix Contact USA
586 Fulling Mill Road
Middletown, PA 17057, United States
(+717) 944-1300
info@phoenixcon.com