

HC-WR/PG16 - Protective hose



1666841

<https://www.phoenixcontact.com/us/products/1666841>

Please be informed that the data shown in this PDF document is generated from our online catalog. Please find the complete data in the user documentation. Our general terms of use for downloads are valid.

Protective hose, for protective house screw connection, packing volume: 50 m, Pg16



Commercial data

Item number	1666841
Packing unit	1 m
Note	Made to order (non-returnable)
Sales key	BF66
Product key	AF7AZW
GTIN	4017918136888
Weight per piece (including packing)	1.494 kg
Weight per piece (excluding packing)	1.494 kg
Customs tariff number	39173900
Country of origin	DE

HC-WR/PG16 - Protective hose



1666841

<https://www.phoenixcontact.com/us/products/1666841>

Technical data

Product properties

Product type	Protective hose
Pg screw connection	Pg16

Material specifications

Color	gray
Material	PA
Flammability rating according to UL 94	HB

Cable/line

External cable diameter	0.1 mm ... 21.2 mm
Bending radius, static	45.00 mm
Smallest bending radius, movable installation	45 mm

Environmental and real-life conditions

Ambient conditions

Ambient temperature (operation)	-40 °C ... 110 °C
Durability	700 N 100 mm based on size M25 700 N / 100 mm (based on size M25)

Drawings

Dimensional drawing

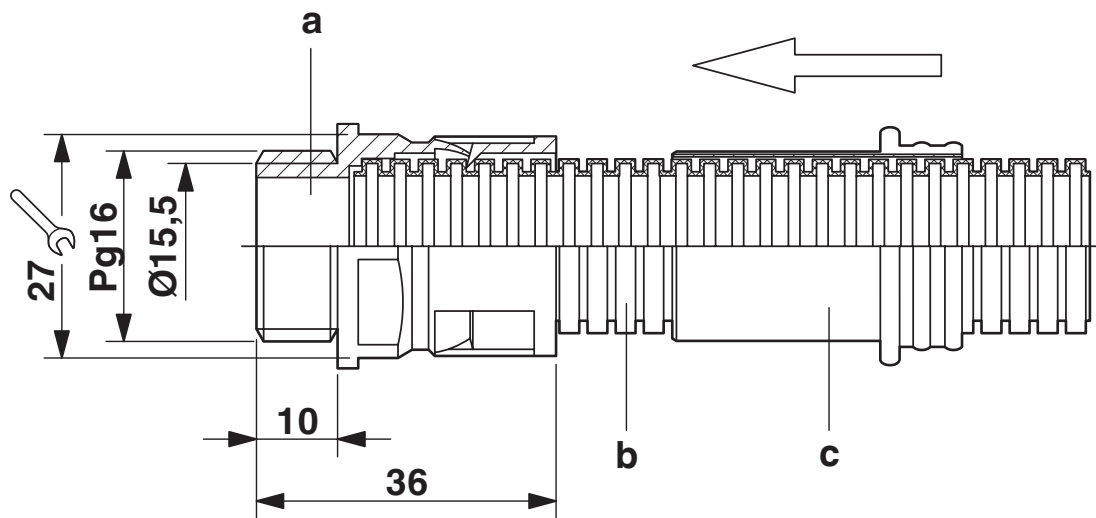

Assembly instructions for Pg16 corrugated pipe

a = Corrugated screw connection

B = Corrugated pipe

c = Opener

Installation note:

Cut the corrugated pipe in the groove to retain a round shape for insertion. The lighter seal (not depicted in the illustration) is positioned in the corrugated pipe screw connection below the safety latch. The darker outer seal (not depicted in the illustration) is placed over the corrugated pipe screw connection from outside. The corrugated pipe is then pushed as far as possible into the corrugated pipe screw connection and clicks into place. The screw connection is opened by placing the yellow corrugated pipe opener with force between the safety latch and the corrugated tube and the corrugated pipe is then pulled out.

HC-WR/PG16 - Protective hose



1666841

<https://www.phoenixcontact.com/us/products/1666841>

Environmental product compliance

EU REACH SVHC

REACH candidate substance (CAS No.)	
-------------------------------------	--

	No substance above 0.1 wt%
--	----------------------------

Phoenix Contact 2026 © - all rights reserved

<https://www.phoenixcontact.com>

Phoenix Contact USA
586 Fulling Mill Road
Middletown, PA 17057, United States
(+717) 944-1300
info@phoenixcon.com