

# CK2,5-ED-0,50ST AG - Crimp contact



1663572

<https://www.phoenixcontact.com/us/products/1663572>

Please be informed that the data shown in this PDF document is generated from our online catalog. Please find the complete data in the user documentation. Our general terms of use for downloads are valid.



Crimp contact, series: HC-M-06, Pin, turned, contact diameter: 2.5 mm, rated current: 16 A, connection cross section: 0.5 mm<sup>2</sup> ... 0.5 mm<sup>2</sup>, AWG 20...20, contact material: Cu alloy

## Commercial data

Item number	1663572
Packing unit	100 pc
Minimum order quantity	100 pc
Sales key	BF65
Product key	AF7AID
GTIN	4017918123383
Weight per piece (including packing)	1.336 g
Weight per piece (excluding packing)	1.336 g
Customs tariff number	85366990
Country of origin	DE

# CK2,5-ED-0,50ST AG - Crimp contact



1663572

<https://www.phoenixcontact.com/us/products/1663572>

## Technical data

### Notes

Notes on the product family	for HC-M-06..., HC-M-HV-, HC-M-08-, HC-M-20-, HC-A..., HC-B.., HC-BB..., HC-BBB..., and HC-HV contact carriers
Assembly note	The quality of a crimp connection is determined by DIN EN 60352-2.
Assembly note	<p>Note on crimp connection technology:</p> <p>For flexible wires only. The specified conductor cross-sections refer to the nominal cross-section of the cable used.</p> <p>The wiring space of the crimp connection technology is designed for fine-stranded cables in accordance with VDE 0295 Class 5. Deviating cable structures (e.g., Class 1.2 and 6 or AWG cables) should be checked before use.</p>

### Product properties

Product type	Crimp contact
Series	HC-M-06 HC-M-HV HC-M-08 HC-A HC-BB HC-B HC-HV HC-M-20 HC-K HC-BBB HC-Q HC-COM
Contact material type	turned

### Connection data

#### Connection technology

Contact connection type	Pin
Connection method	Crimp connection

#### Conductor connection

Stripping length	7.5 mm (9.5 mm at HC-M-HV...)
Connection cross section	0.5 mm <sup>2</sup> ... 0.5 mm <sup>2</sup>
Connection cross section AWG	20 ... 20

### Material specifications

Material Contact	Cu alloy
Material Contact surface	Ag

# CK2,5-ED-0,50ST AG - Crimp contact



1663572

<https://www.phoenixcontact.com/us/products/1663572>

## Dimensions

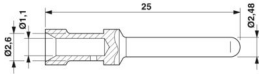
Dimensional drawing	
Diameter (Contact diameter)	2.5 mm

## Electrical properties

Rated current	16 A (Take into account the derating of the contact insert used. The rated current corresponds to the maximum possible connection cross-section.)
---------------	---

## Mechanical properties

Mechanical data	
Insertion/withdrawal cycles	≥ 500

## Environmental and real-life conditions

Ambient conditions	
Ambient temperature (operation)	-40 °C ... 125 °C

# CK2,5-ED-0,50ST AG - Crimp contact



1663572

<https://www.phoenixcontact.com/us/products/1663572>

## Drawings

Dimensional drawing

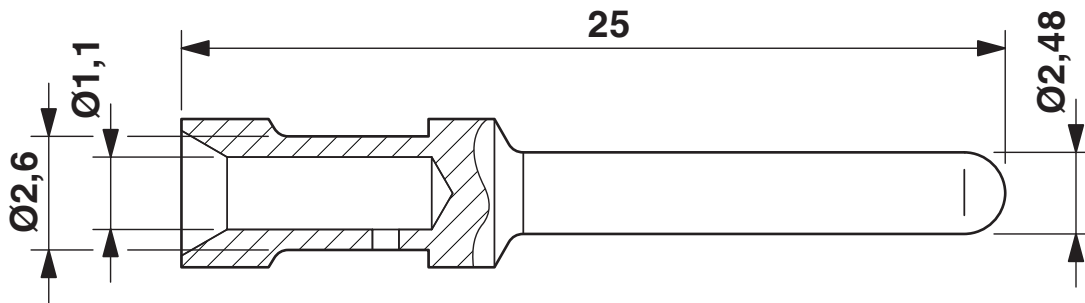

Dimensional drawing

# CK2,5-ED-0,50ST AG - Crimp contact



1663572

<https://www.phoenixcontact.com/us/products/1663572>

## Classifications

### ECLASS

ECLASS-13.0	27440204
ECLASS-15.0	27440204

### ETIM

ETIM 10.0	EC000796
-----------	----------

### UNSPSC

UNSPSC 21.0	39121500
-------------	----------

# CK2,5-ED-0,50ST AG - Crimp contact



1663572

<https://www.phoenixcontact.com/us/products/1663572>

## Environmental product compliance

### EU RoHS

Fulfills EU RoHS substance requirements	Yes, No exemptions
---	--------------------

### China RoHS

Environment friendly use period (EFUP)	EFUP-E
	No hazardous substances above the limits

### EU REACH SVHC

REACH candidate substance (CAS No.)	No substance above 0.1 wt%
-------------------------------------	----------------------------

### EF3.1 Climate Change

CO2e kg	0.021 kg CO2e
---------	---------------

Phoenix Contact 2026 © - all rights reserved  
<https://www.phoenixcontact.com>

Phoenix Contact USA  
586 Fulling Mill Road  
Middletown, PA 17057, United States  
(+717) 944-1300  
[info@phoenixcon.com](mailto:info@phoenixcon.com)