

# VS-08-SET 3 - RJ45 connector

1652648

<https://www.phoenixcontact.com/us/products/1652648>

Please be informed that the data shown in this PDF document is generated from our online catalog. Please find the complete data in the user documentation. Our general terms of use for downloads are valid.



RJ45 sleeve housing, IP67, with push-pull interlocking for panel mounting frames, for cable cross section 5.0 mm ... 6.5 mm, with pin insert VS-08-ST-RJ45, CAT5e, for litz wires AWG 26 and solid wires AWG 26 ... 24

## Commercial data

Item number	1652648
Packing unit	1 pc
Note	Made to order (non-returnable)
Sales key	NULL
Product key	ABNMAY
GTIN	4046356028707
Weight per piece (including packing)	18.2 g
Weight per piece (excluding packing)	18.2 g
Customs tariff number	85369010
Country of origin	DE

# VS-08-SET 3 - RJ45 connector

1652648

<https://www.phoenixcontact.com/us/products/1652648>



## Drawings

Dimensional drawing

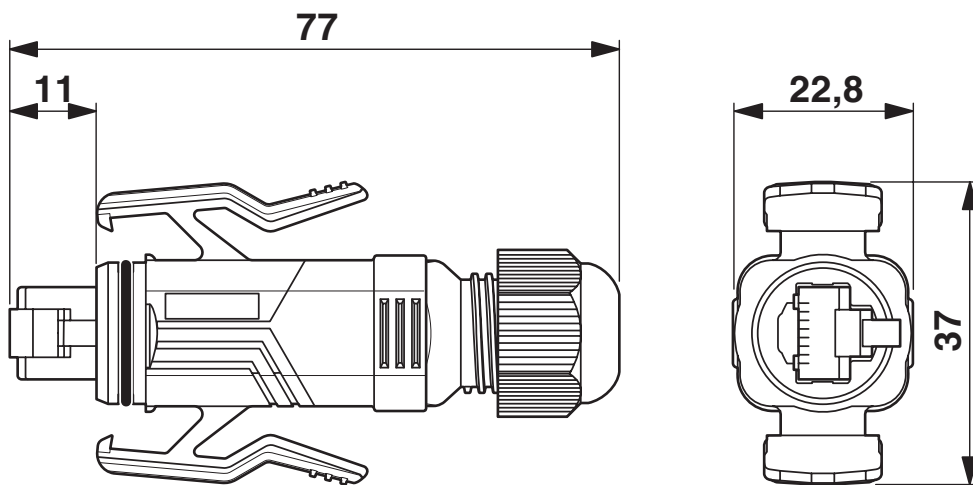

RJ45 connectors, IP67, QUICKON fast connection technology

# VS-08-SET 3 - RJ45 connector



1652648

<https://www.phoenixcontact.com/us/products/1652648>

## Environmental product compliance

### EU RoHS

Fulfills EU RoHS substance requirements	Yes, No exemptions
---	--------------------

### EU REACH SVHC

REACH candidate substance (CAS No.)	No substance above 0.1 wt%
-------------------------------------	----------------------------

Phoenix Contact 2026 © - all rights reserved

<https://www.phoenixcontact.com>

Phoenix Contact USA  
586 Fulling Mill Road  
Middletown, PA 17057, United States  
(+717) 944-1300  
[info@phoenixcon.com](mailto:info@phoenixcon.com)