

# HC-B 10-SFQD-74/O2M25 - Housing



1646515

<https://www.phoenixcontact.com/us/products/1646515>

Please be informed that the data shown in this PDF document is generated from our online catalog. Please find the complete data in the user documentation. Our general terms of use for downloads are valid.



HEAVYCON box mounting base B10, for double locking latch, height 74 mm, with supports 2xM25, with cover

## Commercial data

Item number	1646515
Packing unit	10 pc
Minimum order quantity	1 pc
Product key	AF7AAC
GTIN	4017918985196
Weight per piece (including packing)	410.3 g
Weight per piece (excluding packing)	410.3 g
Country of origin	DE

# HC-B 10-SFQD-74/O2M25 - Housing

1646515

<https://www.phoenixcontact.com/us/products/1646515>

## Technical data

### Notes

General	For contact inserts HC-B10, BB18, DD42, M, K8/24
---------	--

### Product properties

Product type	Housing with locking latch
Housing type	Surface mounting housing
Application	Standard
Type	B10
No. of cable outlets	2
Type of the screw connection	2x M25
Protective cover	yes
Shielded	no
Cable outlet	lateral
Pg screw connection	none

### Dimensions

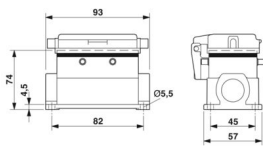
Dimensional drawing	
Width	57 mm
Height	74 mm
Length	93 mm

### Material specifications

Seal material	NBR
Housing material	Die-cast aluminum
Housing surface material	Powder-coated, gray
Material, protective cover	PA

### Mechanical properties

#### Mechanical data

Type of the screw connection	2x M25
Locking type	Pin

### Environmental and real-life conditions

#### Ambient conditions

Degree of protection	IP65 (When plugged in)
Ambient temperature (operation)	-40 °C ... 125 °C

# HC-B 10-SFQD-74/O2M25 - Housing

1646515

<https://www.phoenixcontact.com/us/products/1646515>



## Drawings

Dimensional drawing

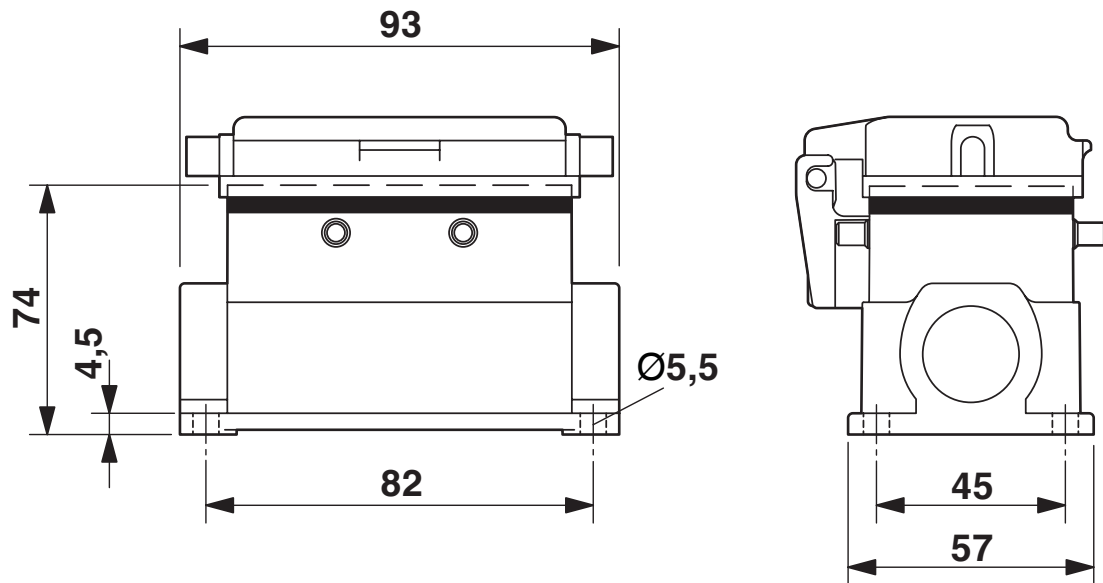

Dimensional drawing

# HC-B 10-SFQD-74/O2M25 - Housing



1646515

<https://www.phoenixcontact.com/us/products/1646515>

## Classifications

### ECLASS

ECLASS-13.0	27440202
ECLASS-15.0	27440202

# HC-B 10-SFQD-74/O2M25 - Housing



1646515

<https://www.phoenixcontact.com/us/products/1646515>

## Environmental product compliance

### EU RoHS

Fulfills EU RoHS substance requirements	Yes, No exemptions
---	--------------------

### China RoHS

Environment friendly use period (EFUP)	EFUP-E
	No hazardous substances above the limits

### EU REACH SVHC

REACH candidate substance (CAS No.)	No substance above 0.1 wt%
-------------------------------------	----------------------------

Phoenix Contact 2026 © - all rights reserved  
<https://www.phoenixcontact.com>

Phoenix Contact USA  
586 Fulling Mill Road  
Middletown, PA 17057, United States  
(+717) 944-1300  
[info@phoenixcon.com](mailto:info@phoenixcon.com)