

HC-B 16-SFQD-84/O2M32 - Housing



1645668

<https://www.phoenixcontact.com/us/products/1645668>

Please be informed that the data shown in this PDF document is generated from our online catalog. Please find the complete data in the user documentation. Our general terms of use for downloads are valid.



HEAVYCON B16 box mounting base, for double locking latch, height: 84 mm, with 2 x M32 glands, with cover

Commercial data

Item number	1645668
Packing unit	10 pc
Minimum order quantity	1 pc
Product key	AF7AAC
GTIN	4017918957902
Weight per piece (including packing)	434.13 g
Weight per piece (excluding packing)	434.13 g
Country of origin	DE

HC-B 16-SFQD-84/O2M32 - Housing

1645668

<https://www.phoenixcontact.com/us/products/1645668>

Technical data

Notes

General	For contact inserts HC-B16, BB32, BBB40, D40, DD72, HS6, M, K
---------	---------------------------------------------------------------

Product properties

Product type	Housing with locking latch
Housing type	Surface mounting housing
Application	Standard
Type	B16
No. of cable outlets	2
Type of the screw connection	2x M32
Protective cover	yes
Shielded	no
Cable outlet	lateral
Pg screw connection	none

Dimensions

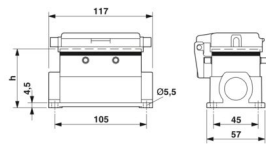
Dimensional drawing	
Width	57 mm
Height	84 mm
Length	117 mm

Material specifications

Seal material	NBR
Housing material	Die-cast aluminum
Housing surface material	Powder-coated, gray
Material, protective cover	PA

Mechanical properties

Mechanical data

Type of the screw connection	2x M32
Locking type	Pin

Environmental and real-life conditions

Ambient conditions

Degree of protection	IP65 (When plugged in)
Ambient temperature (operation)	-40 °C ... 125 °C

HC-B 16-SFQD-84/O2M32 - Housing

1645668

<https://www.phoenixcontact.com/us/products/1645668>



Drawings

Dimensional drawing

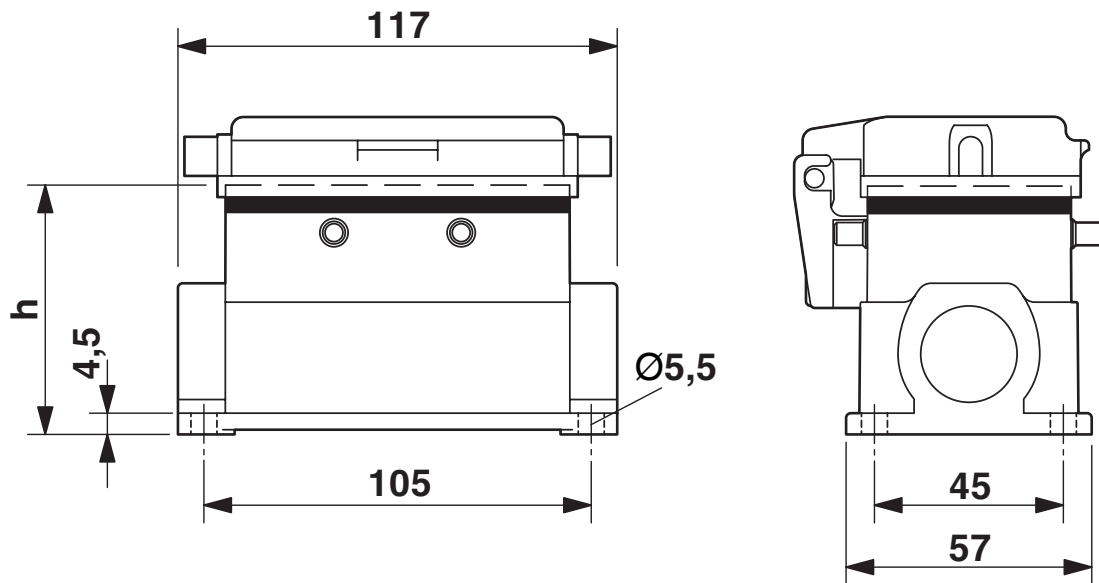

Dimensional drawing

HC-B 16-SFQD-84/O2M32 - Housing



1645668

<https://www.phoenixcontact.com/us/products/1645668>

Classifications

ECLASS

ECLASS-13.0	27440202
ECLASS-15.0	27440202

UNSPSC

UNSPSC 21.0	31261501
-------------	----------

HC-B 16-SFQD-84/O2M32 - Housing



1645668

<https://www.phoenixcontact.com/us/products/1645668>

Environmental product compliance

EU RoHS

Fulfills EU RoHS substance requirements	Yes, No exemptions
-----------------------------------------	--------------------

China RoHS

Environment friendly use period (EFUP)	EFUP-E
	No hazardous substances above the limits

EU REACH SVHC

REACH candidate substance (CAS No.)	No substance above 0.1 wt%
-------------------------------------	----------------------------

Phoenix Contact 2026 © - all rights reserved
<https://www.phoenixcontact.com>

Phoenix Contact USA
586 Fulling Mill Road
Middletown, PA 17057, United States
(+717) 944-1300
info@phoenixcon.com