

Q 1,5/2A50/11-11KU-ESA - Panel feed-through



1640948

<https://www.phoenixcontact.com/us/products/1640948>

Please be informed that the data shown in this PDF document is generated from our online catalog. Please find the complete data in the user documentation. Our general terms of use for downloads are valid.

Panel feed-through with wire exit 1.5 mm² and 0.5 m Litz wire, connecting thread: Pg11, 2-pos.



Your advantages

- Robust throughout: housing with IP65/IP67 protection for a wide range of applications

Commercial data

Item number	1640948
Packing unit	1 pc
Note	Made to order (non-returnable)
Sales key	BF50
Product key	AF6HAB
GTIN	4017918181383
Weight per piece (including packing)	38.75 g
Weight per piece (excluding packing)	38.75 g
Customs tariff number	85366990
Country of origin	DE

Q 1,5/2A50/11-11KU-ESA - Panel feed-through



1640948

<https://www.phoenixcontact.com/us/products/1640948>

Technical data

Product properties

Product type	Panel feed-through
Number of positions	2
Connection profile	2
Number of connections	2
Number of connections per position	1
Shielded	no

Insulation characteristics

Overvoltage category	III
Degree of pollution	3

Connection data

Connection technology

Connection method On the device side	Single wires
Frequency of connections between conductors of the same cross section	10 (if the conductor is connected more than once, seal and cap may need to be replaced.)

Conductor connection

Conductor cross-section flexibel	0.75 mm ² ... 1.5 mm ²
Conductor cross-section solid	0.75 mm ² ... 1.5 mm ²
Connection cross section AWG	18 ... 16
Tightening torque Union nut	2.5 Nm
Tightening torque Contact carrier	3.75 Nm
Tightening torque Locking nut	3.75 Nm
Wrench size Union nut	22 mm
Wrench size Contact carrier	22 mm

Connection assignment

Contact Color (signal designation) Contact (optional)	1 BN
	2 WH

Dimensions

Dimensional drawing	
Width	22 mm

Q 1,5/2A50/11-11KU-ESA - Panel feed-through



1640948

<https://www.phoenixcontact.com/us/products/1640948>

Height	22 mm
Length	45 mm
Diameter	22 mm

Electrical properties

Rated surge voltage (II/2)	4 kV
Rated surge voltage (III/2)	4 kV
Rated surge voltage (III/3)	4 kV
Contact resistance	3 mΩ
rated voltage (II/2)	630 V (with insulating sleeve)
rated voltage (III/2)	320 V (with insulating sleeve)
Rated voltage (III/3)	250 V (with insulating sleeve)
Nominal voltage U_N	250 V
Nominal current I_N	17.5 A

Material specifications

Color (Housing)	green (RAL 6021)
Material Housing	PA
Flammability rating according to UL 94	V0
Material wire insulation	PVC / PE
Contact material	Copper alloy
Contact surface material	Pre-nickel plated and tin-plated
Contact carrier material	PA 6.6

Cable/line

Cable length	0.5 m
Structure of individual litz in acc. with VDE 0295 / smallest wire diameter	VDE 0295 Cl.2-5, min. wire diameter 0.2 mm
External cable diameter	4 mm ... 7.5 mm
Wire diameter including insulation	≥ 3 mm
Cable cross section	1.5 mm ²

Mounting

Mounting type	Front mounting Pg11
Assembly note	If the conductor is reconnected, it must be cut off above the last contact point. QUICKON components may only be operated when under no load.

Environmental and real-life conditions

Ambient conditions

Degree of protection	IP65 IP67
Impact strength	IK06
Ambient temperature (operation)	-25 °C ... 80 °C (Specifications of the cable manufacturer must be observed.)

Q 1,5/2A50/11-11KU-ESA - Panel feed-through



1640948

<https://www.phoenixcontact.com/us/products/1640948>

	-25 °C ... 50 °C (when the conductor is connected. Specifications of the cable manufacturer must also be observed.)
Temperature when conductor connected	-5 °C ... 50 °C

Q 1,5/2A50/11-11KU-ESA - Panel feed-through



1640948

<https://www.phoenixcontact.com/us/products/1640948>

Drawings

Dimensional drawing

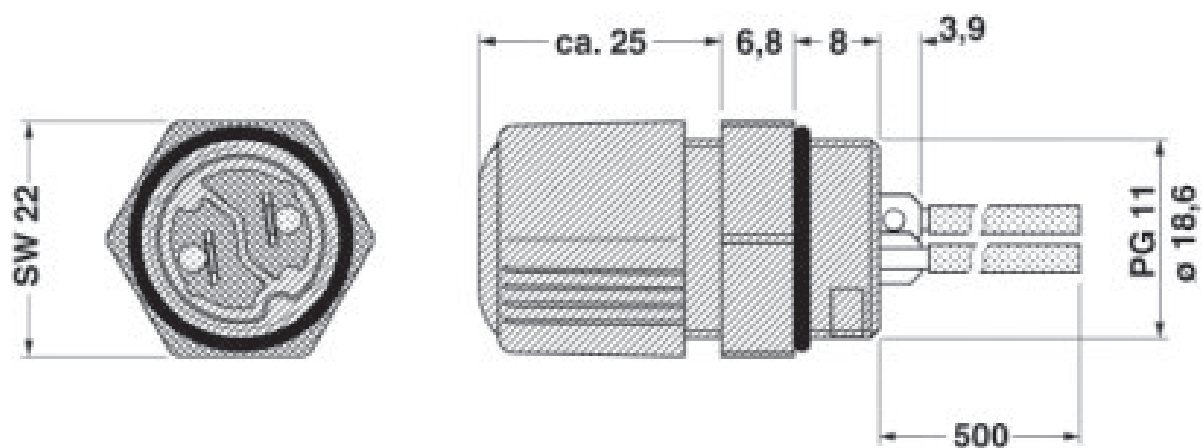

Q 1,5/2A50/11-11KU-ESA - Panel feed-through



1640948

<https://www.phoenixcontact.com/us/products/1640948>

Classifications

ECLASS

ECLASS-13.0	27440602
ECLASS-15.0	27440602

Q 1,5/2A50/11-11KU-ESA - Panel feed-through



1640948

<https://www.phoenixcontact.com/us/products/1640948>

Environmental product compliance

EU REACH SVHC

REACH candidate substance (CAS No.)	No substance above 0.1 wt%
-------------------------------------	----------------------------

Phoenix Contact 2026 © - all rights reserved

<https://www.phoenixcontact.com>

Phoenix Contact USA
586 Fulling Mill Road
Middletown, PA 17057, United States
(+717) 944-1300
info@phoenixcon.com