

EV-T1L2CC-DC125A-5,5M1ASBK01 - DC charging cable



1628122

<https://www.phoenixcontact.com/us/products/1628122>

Please be informed that the data shown in this PDF document is generated from our online catalog. Please find the complete data in the user documentation. Our general terms of use for downloads are valid.



CHARX connect, CCS type 1, cable: 5.5 m, SAE J1772, IEC 62196-3, DC charging cable with vehicle connector, open cable end, NOTE: Cable management may be required.

Product description

DC charging cable with vehicle charging connector and free cable end for fast charging of electric vehicles (EV) with direct current (DC) via CCS type 1 vehicle charging inlets, for installation at charging stations for e-mobility (EVSE)

Your advantages

- Consistent design of all Phoenix Contact Vehicle Connectors and Infrastructure Plugs
- Silver-plated surface of the power and signal contacts
- Developed and produced in accordance with the IATF 16949 automotive standard and ISO 9001
- Convenient handling, thanks to the ergonomic handle and additional, rubber grip components
- Integrated temperature sensors for monitoring the temperature at the power contacts

Commercial data

Item number	1628122
Packing unit	1 pc
Note	Made to order (non-returnable)
Sales key	EM01
Product key	XWBAAB
GTIN	4055626385358
Weight per piece (including packing)	12.34 kg
Weight per piece (excluding packing)	12.17 kg
Customs tariff number	85444290
Country of origin	DE

EV-T1L2CC-DC125A-5,5M1ASBK01 - DC charging cable



1628122

<https://www.phoenixcontact.com/us/products/1628122>

Technical data

Product properties

Product type	DC charging cable
Product family	CHARX connect
Charging standard	CCS type 1
Charging mode	Mode 4

Electrical properties

Charging power and current (DC charging)

Type of charging current	DC
Charging current	125 A DC
Charging power	125 kW
Rated voltage	1000 V

Temperature sensors (Pt 1000)

Sensor type	Pt 1000
Standards/regulations	DIN EN 60751
Attachment point	Sensor for the DC contacts
Switch-off temperature	90 °C ±1 K (equivalent to a Pt 1000 value of 1346.5 Ω)
Long-term stability	0.06 % (after 1000 hours at 130 °C)
Recommended measured current	1 mA (1 V at 0°C)
Coefficient	3850 ppm/K
Ambient temperature	-50 °C ... 130 °C (Operation)

Cable/line

Cable length	5.5 m
Stripping length of the sheath	130 mm ±20 mm
Stripping length	130 mm ±20 mm

Standards and regulations

Standards

Standards/regulations	SAE J1772
	IEC 62196-3

EV-T1L2CC-DC125A-5,5M1ASBK01 - DC charging cable

1628122

<https://www.phoenixcontact.com/us/products/1628122>

Drawings



Make sure that the vehicle charging connector is placed in an appropriate charging connector holder, which ensures a minimum protection rating of IP24 in accordance with IEC 61851-1, for the entire time between charging. To create this charging connector holder, use the dimensions of the vehicle charging connector. Detailed dimensions can also be found in the Download area.

Connection diagram



Pin assignment of the Vehicle Connector

EV-T1L2CC-DC125A-5,5M1ASBK01 - DC charging cable

1628122

<https://www.phoenixcontact.com/us/products/1628122>

Schematic diagram



“Combined Charging System” principle

Schematic diagram



Operating instructions

EV-T1L2CC-DC125A-5,5M1ASBK01 - DC charging cable

1628122

<https://www.phoenixcontact.com/us/products/1628122>

Schematic diagram

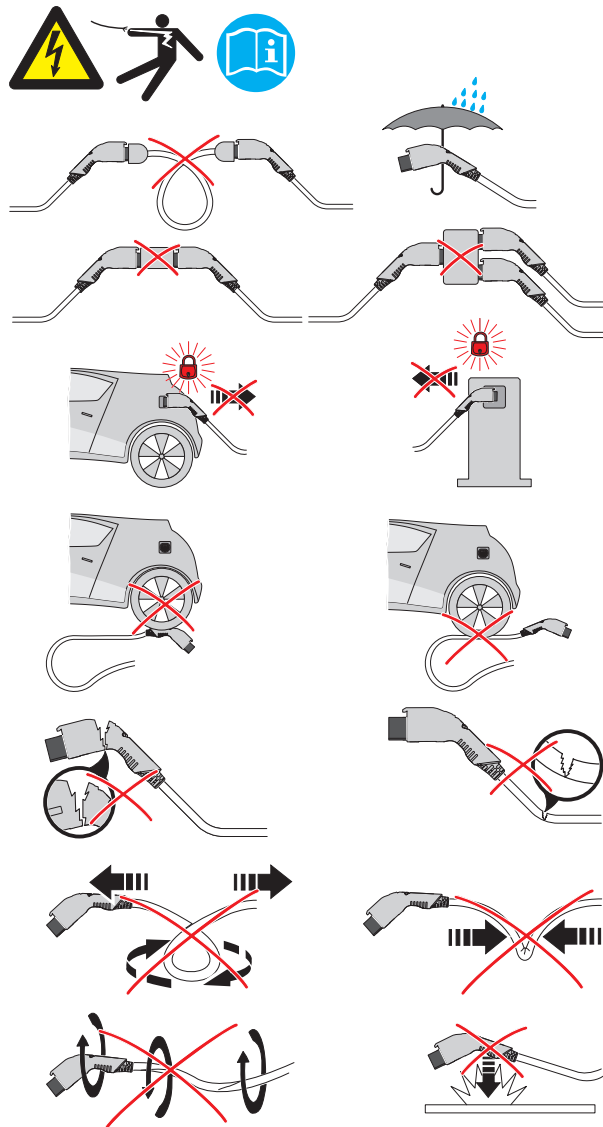

Warnings regarding use

EV-T1L2CC-DC125A-5,5M1ASBK01 - DC charging cable

1628122

<https://www.phoenixcontact.com/us/products/1628122>

Schematic diagram

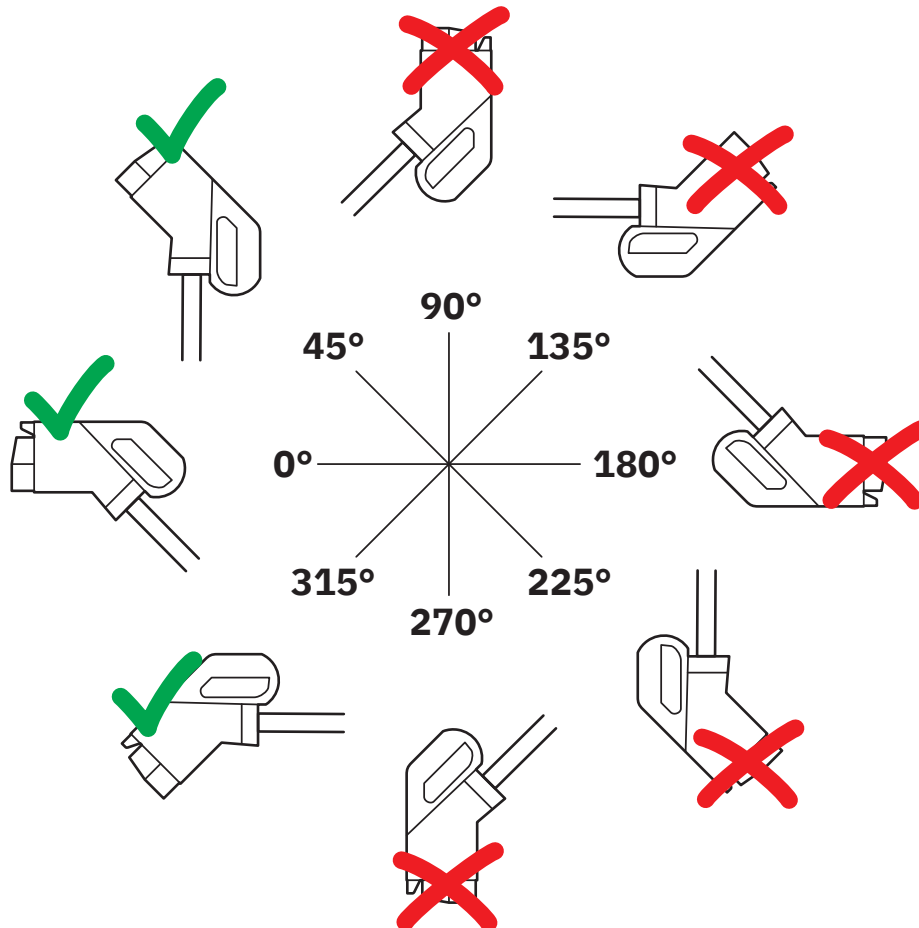

The resting position must be installed in the charging station such that the user cannot hang up the vehicle connector upside down (90° to 270°). However, positions rotated upward (45°) or downward (315°) are options for a resting position.

EV-T1L2CC-DC125A-5,5M1ASBK01 - DC charging cable



1628122

<https://www.phoenixcontact.com/us/products/1628122>

Environmental product compliance

China RoHS

Environment friendly use period (EFUP)	EFUP-10 An article-related China RoHS declaration table can be found in the download area for the respective article under "Manufacturer declaration". For all articles with EFUP-E, no China RoHS declaration table issued and required.
--	--

EU REACH SVHC

REACH candidate substance (CAS No.)	No substance above 0.1 wt%
-------------------------------------	----------------------------

Phoenix Contact 2026 © - all rights reserved
<https://www.phoenixcontact.com>

Phoenix Contact USA
586 Fulling Mill Road
Middletown, PA 17057, United States
(+717) 944-1300
info@phoenixcon.com