

# EV-T2M3SE12-3AC20A-0,5M2,5E11 - Infrastructure charging socket



1627945

<https://www.phoenixcontact.com/us/products/1627945>

Please be informed that the data shown in this PDF document is generated from our online catalog. Please find the complete data in the user documentation. Our general terms of use for downloads are valid.



CHARX connect, Type 2, Infrastructure charging socket, 20 A , 480 V AC, Gen 1, length: 0.5 m, locking actuator: 12 V, 4-pos., Rear panel mounting, additional splash protection at the rear with single-core wire seals, for charging electric vehicles (EV) with alternating current (AC), PHOENIX CONTACT logo, IEC 62196-2

## Product description

Infrastructure charging socket for charging electric vehicles (EV) with alternating current (AC), compatible with type 2 Infrastructure Plugs, for installation at charging stations for E-Mobility (EVSE)

## Your advantages

- Complete product range
- Uniform, space-saving installation space
- Available with your logo on request - for consistent branding of your charging station
- Integrated interlock during charging
- Manual emergency release of the locking actuator
- Developed and produced in accordance with the IATF 16949 automotive standard and ISO 9001

## Commercial data

Item number	1627945
Packing unit	1 pc
Minimum order quantity	1 pc
Product key	XWBADC
GTIN	4055626366920
Weight per piece (including packing)	0.446 kg
Weight per piece (excluding packing)	0.405 kg
Country of origin	DE

# EV-T2M3SE12-3AC20A-0,5M2,5E11 - Infrastructure charging socket



1627945

<https://www.phoenixcontact.com/us/products/1627945>

## Technical data

### Product properties

Product type	Infrastructure charging socket
Product family	CHARX connect
Type	Gen 1
Design	additional splash protection at the rear with single-core wire seals
Charging standard	Type 2
Charging mode	Mode 3, Case B
Affixed logo	PHOENIX CONTACT logo
Customer variations	On request

### Electrical properties

Type of signal transmission	Pulse width modulation
Note on the connection method	Crimp connection, cannot be disconnected

#### Pin assignment (Power contacts)

Number	5 (L1, L2, L3, N, PE)
Rated voltage	480 V AC
Rated current	20 A

#### Pin assignment (Signal contacts)

Number	2 (CP, PP)
Rated voltage	30 V AC
Rated current	2 A

#### Locking actuator

Locking actuator	12 V, 4-pos.
	Top center position
Possible power supply range at the motor	9 V ... 16 V
Maximum voltage for locking detection	30 V
Typical motor current for locking	0.2 A
Reverse current of the motor	max. 1 A
Max. dwell time with reverse current	1000 ms
Recommended adaptation time	600 ms
Pause time after entry or exit path	3 s
Service life insertion cycles	> 10000 load cycles
Lock recognition	available
Mechanical emergency release	available
Ambient temperature (operation)	-30 °C ... 50 °C
Cable length	0.5 m
Cable structure	4 x 0.5 mm <sup>2</sup>

# EV-T2M3SE12-3AC20A-0,5M2,5E11 - Infrastructure charging socket



1627945

<https://www.phoenixcontact.com/us/products/1627945>

## Dimensions

### Infrastructure charging socket

Width	75 mm
Height	96 mm
Depth	76.2 mm

### Bore dimensions

Width	60 mm
Height	60 mm

## Cable/line

Cable length	0.5 m (AC cables)
	0.5 m (Locking actuator cables)
Cable structure	5 x 2.5 mm <sup>2</sup> + 2 x 0.5 mm <sup>2</sup>

## Mechanical properties

### Mechanical data

Insertion/withdrawal cycles	> 10000
Insertion force	< 100 N
Withdrawal force	< 100 N

## Environmental and real-life conditions

### Ambient conditions

Ambient temperature (operation)	-30 °C ... 50 °C
Ambient temperature (storage/transport)	-40 °C ... 80 °C
Altitude	5000 m (above sea level)

## Standards and regulations

### Standards

Standards/regulations	IEC 62196-2
-----------------------	-------------

## Mounting

Mounting type Infrastructure charging socket	Rear panel mounting (0 to 90 degree frontal inclination possible)
	Front mounting (only possible when the locking actuator is removed (see EV-T2M3SE...E00 versions))
Mounting type Protective cover	rear (available separately)
Mounting hole diameter	7.00 mm (ø)

# EV-T2M3SE12-3AC20A-0,5M2,5E11 - Infrastructure charging socket



1627945

<https://www.phoenixcontact.com/us/products/1627945>

## Drawings

Dimensional drawing

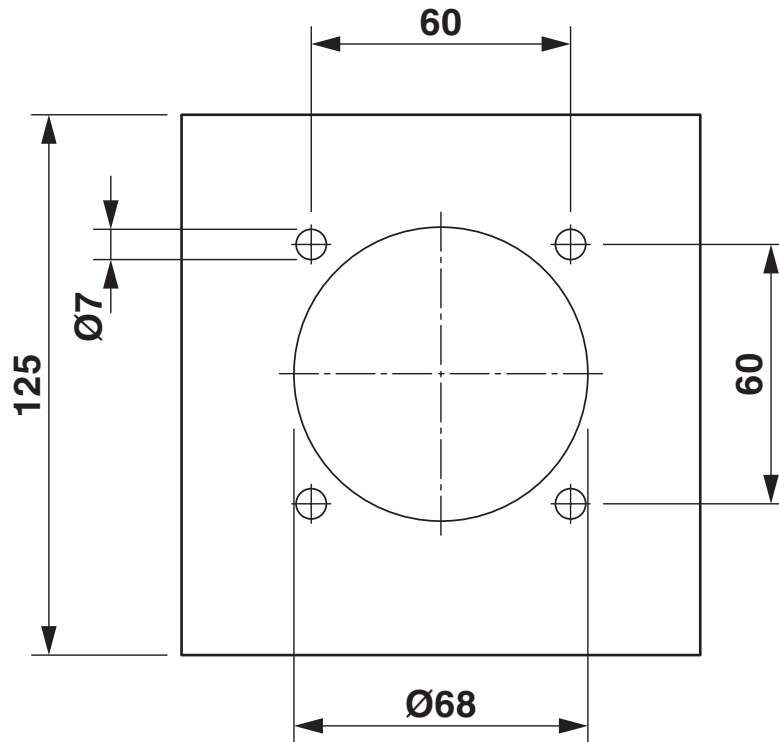

Hole image

# EV-T2M3SE12-3AC20A-0,5M2,5E11 - Infrastructure charging socket



1627945

<https://www.phoenixcontact.com/us/products/1627945>

Dimensional drawing



Dimensional drawing

# EV-T2M3SE12-3AC20A-0,5M2,5E11 - Infrastructure charging socket

1627945

<https://www.phoenixcontact.com/us/products/1627945>

Connection diagram

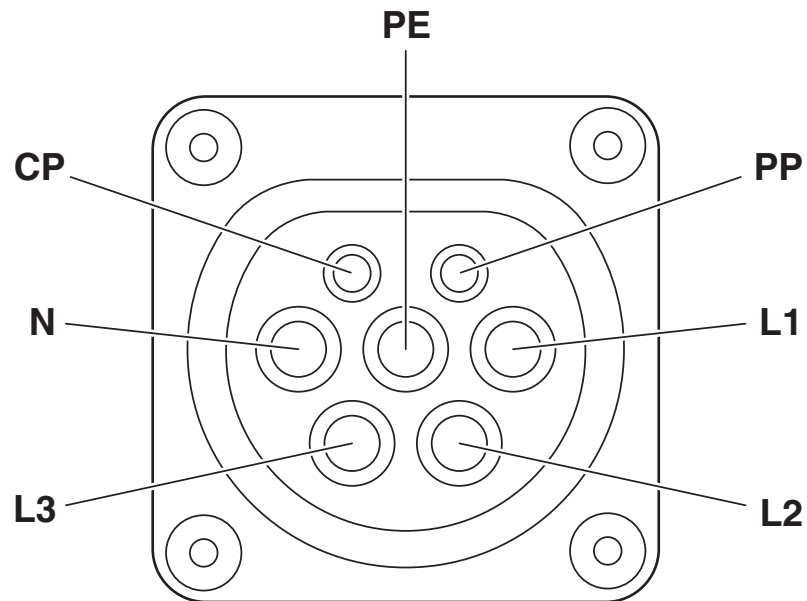

Pin assignment of infrastructure charging socket

# EV-T2M3SE12-3AC20A-0,5M2,5E11 - Infrastructure charging socket

1627945

<https://www.phoenixcontact.com/us/products/1627945>

Schematic diagram

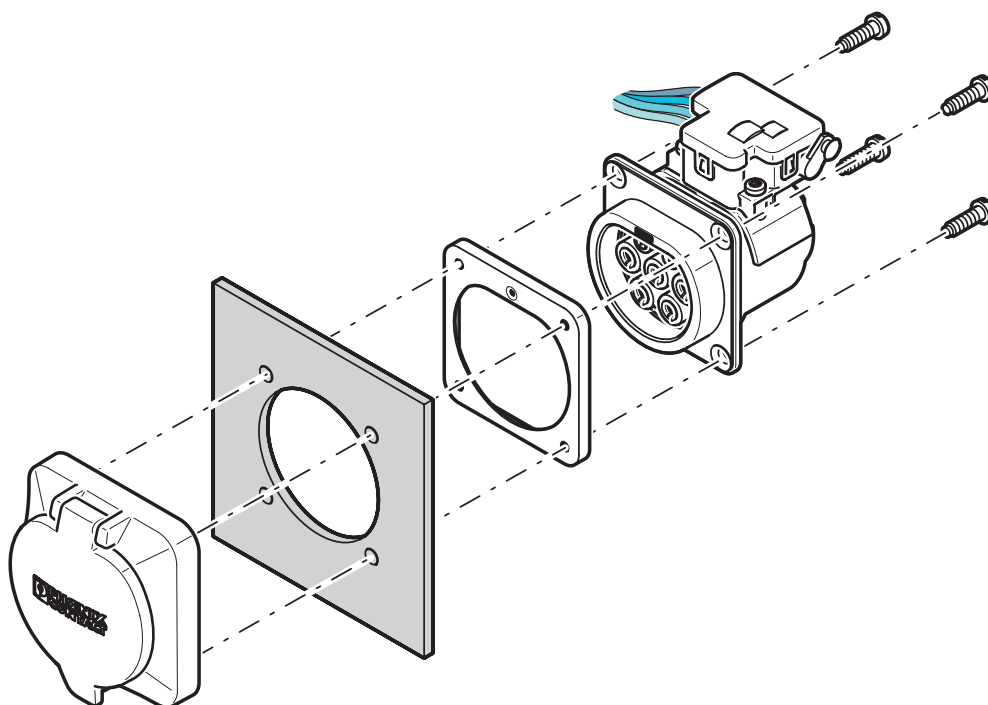

## Rear mounting with rear protective cover screw connection

The screw connection for a protective cover from the accessories range (EV-T2SC) only supports rear mounting. The panel thickness must not exceed 5 mm. The sealing frame that is slid on from the rear must contact the housing panel flush with the flat side and must completely surround the infrastructure socket outlet.

# EV-T2M3SE12-3AC20A-0,5M2,5E11 - Infrastructure charging socket

1627945

<https://www.phoenixcontact.com/us/products/1627945>

Schematic diagram

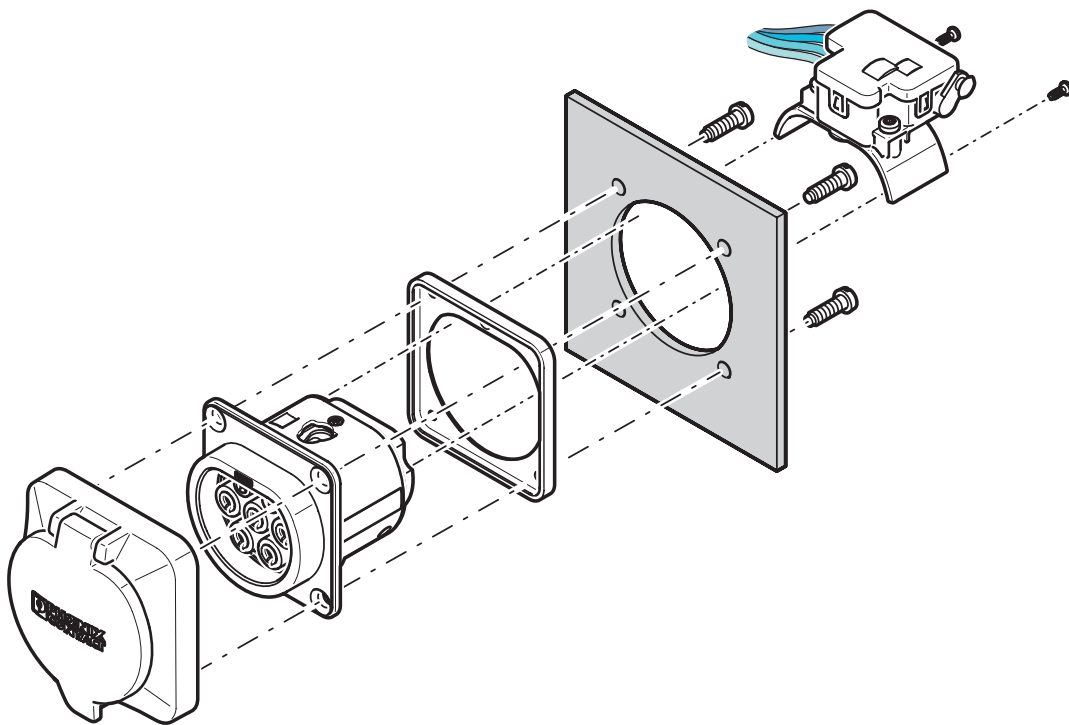

## Front mounting with rear protective cover screw connection

Front mounting is only possible when the locking actuator is removed. We recommend using an infrastructure socket outlet without pre-assembled locking actuator (EV-T2M3SE-...E0..., e.g., 1621729).

The screw connection for a protective cover from the accessories range (EV-T2SC) only supports rear mounting. The panel thickness must not exceed 10 mm. The sealing frame that is slid on from the front must contact the housing panel flush with the flat side and must completely surround the infrastructure socket outlet.

# EV-T2M3SE12-3AC20A-0,5M2,5E11 - Infrastructure charging socket

1627945

<https://www.phoenixcontact.com/us/products/1627945>

Schematic diagram



Operating instructions

# EV-T2M3SE12-3AC20A-0,5M2,5E11 - Infrastructure charging socket

1627945

<https://www.phoenixcontact.com/us/products/1627945>



Detection of the Infrastructure Plug

## Schematic diagram



Installation positions

# EV-T2M3SE12-3AC20A-0,5M2,5E11 - Infrastructure charging socket

1627945

<https://www.phoenixcontact.com/us/products/1627945>

Schematic diagram

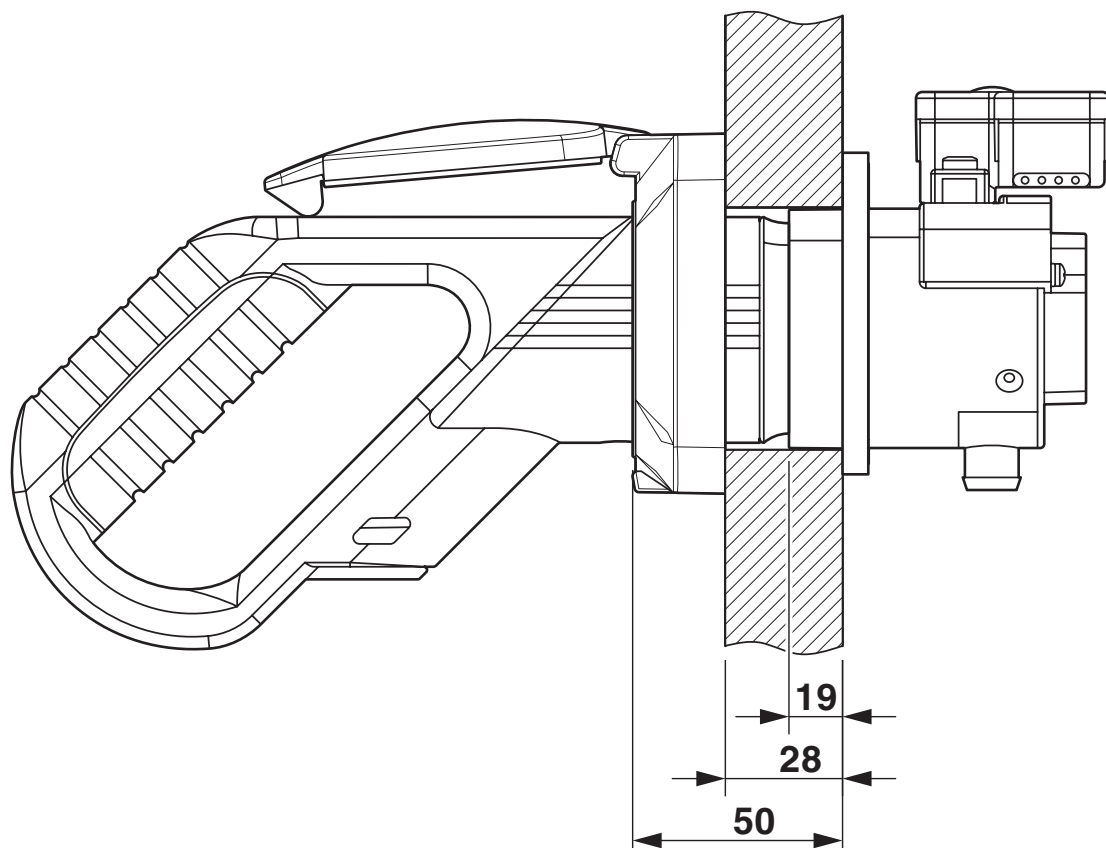

Panel thickness for rear mounting (max. 50 mm, with Phoenix Contact protective cover, max. 22 mm)

# EV-T2M3SE12-3AC20A-0,5M2,5E11 - Infrastructure charging socket

1627945

<https://www.phoenixcontact.com/us/products/1627945>

Schematic diagram

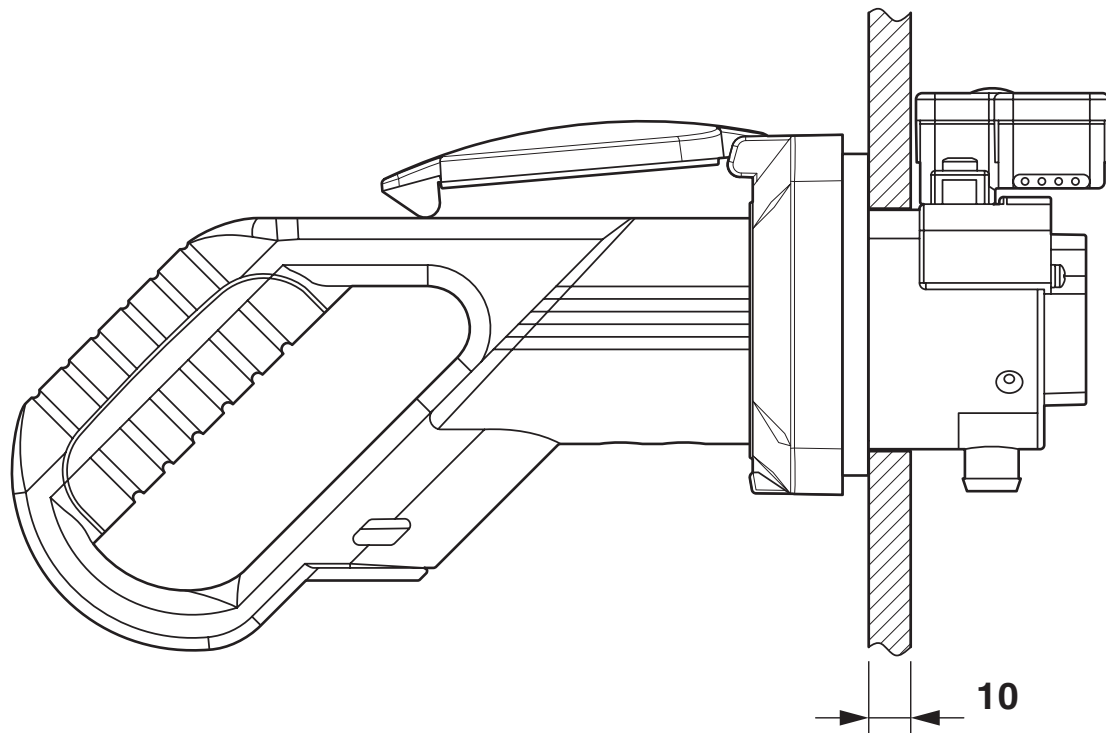

Panel thickness for front mounting (in mm)

# EV-T2M3SE12-3AC20A-0,5M2,5E11 - Infrastructure charging socket

1627945

<https://www.phoenixcontact.com/us/products/1627945>

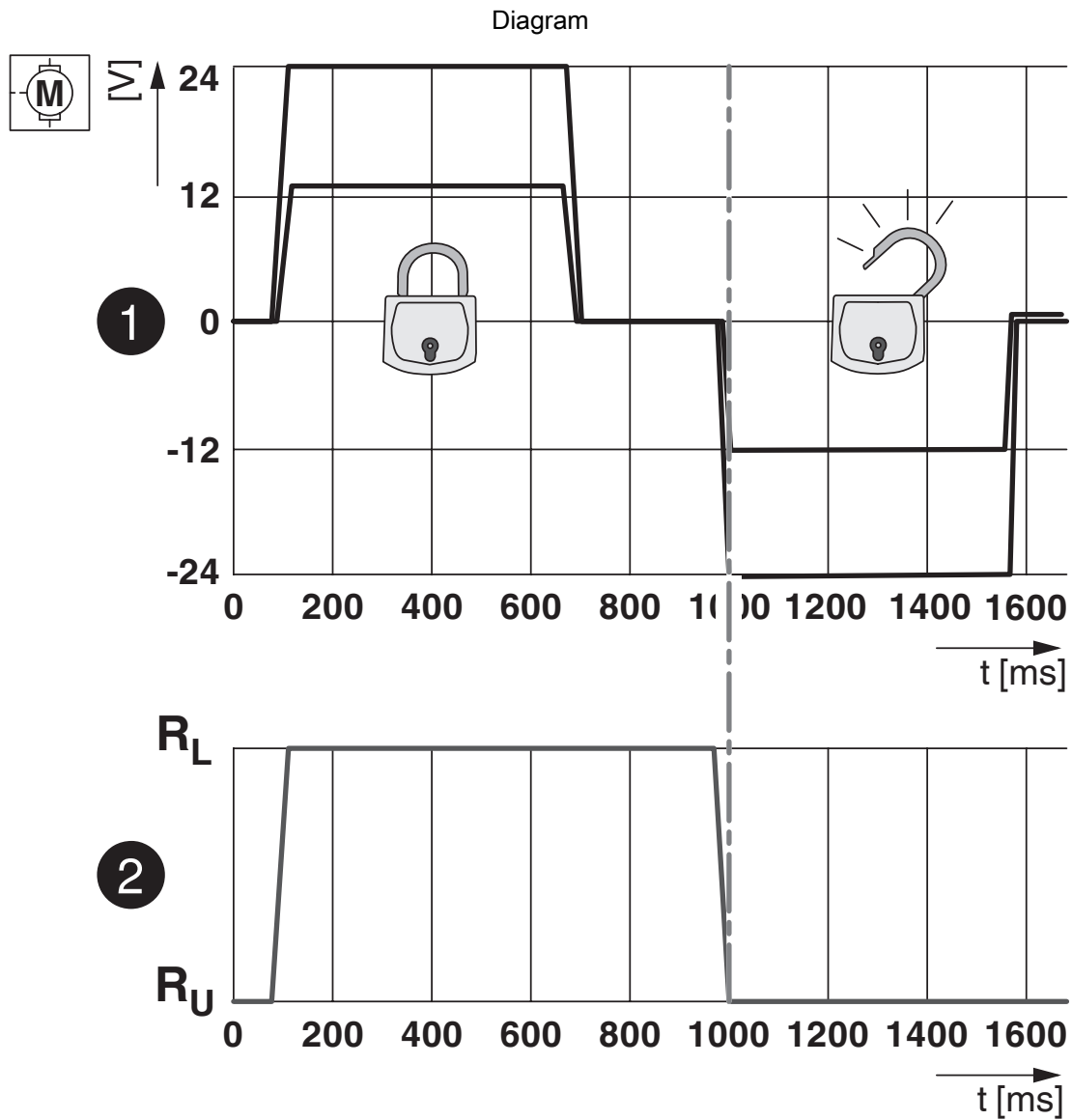

Locking states of the locking actuator

# EV-T2M3SE12-3AC20A-0,5M2,5E11 - Infrastructure charging socket

1627945

<https://www.phoenixcontact.com/us/products/1627945>

Block diagram

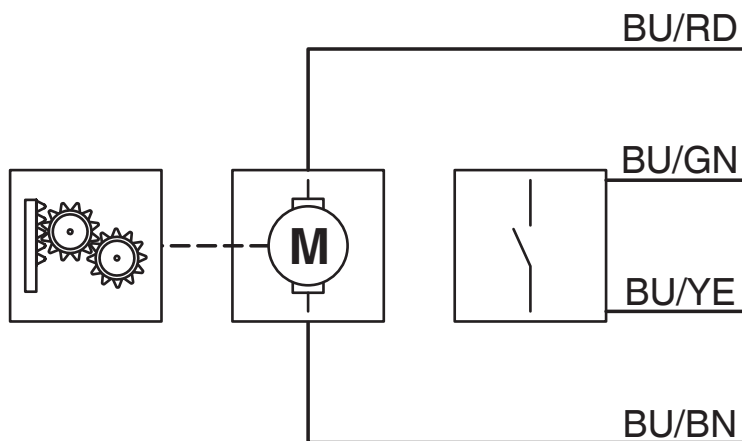

Block diagram of the locking actuator

# EV-T2M3SE12-3AC20A-0,5M2,5E11 - Infrastructure charging socket



1627945

<https://www.phoenixcontact.com/us/products/1627945>

## Classifications

### UNSPSC

UNSPSC 21.0	39121522
-------------	----------

# EV-T2M3SE12-3AC20A-0,5M2,5E11 - Infrastructure charging socket



1627945

<https://www.phoenixcontact.com/us/products/1627945>

## Environmental product compliance

### EU RoHS

Fulfills EU RoHS substance requirements	Yes
Exemption	6(c)

### China RoHS

Environment friendly use period (EFUP)	EFUP-10
	An article-related China RoHS declaration table can be found in the download area for the respective article under "Manufacturer declaration". For all articles with EFUP-E, no China RoHS declaration table issued and required.

### EU REACH SVHC

REACH candidate substance (CAS No.)	Lead(CAS: 7439-92-1)
-------------------------------------	----------------------

Phoenix Contact 2026 © - all rights reserved  
<https://www.phoenixcontact.com>

Phoenix Contact USA  
586 Fulling Mill Road  
Middletown, PA 17057, United States  
(+717) 944-1300  
[info@phoenixcon.com](mailto:info@phoenixcon.com)