

EV-T2CCS-PARK - Charging connector holder



1624153

<https://www.phoenixcontact.com/us/products/1624153>

Please be informed that the data shown in this PDF document is generated from our online catalog. Please find the complete data in the user documentation. Our general terms of use for downloads are valid.



CHARX connect standard, CCS type 2, Charging connector holder, Accessories, Front mounting, housing: black, for vehicle charging connectors on charging stations (EVSE), IEC 62196-3, Item is not compatible with the HPC CCS type 2 charging cable from Phoenix Contact.

Product description

Retainer for Vehicle Connector as parking position at charging stations for E-Mobility (EVSE)

Commercial data

Item number	1624153
Packing unit	1 pc
Minimum order quantity	1 pc
Sales key	EM01
Product key	XWBMY
GTIN	4055626242873
Weight per piece (including packing)	182.9 g
Weight per piece (excluding packing)	131 g
Customs tariff number	39269097
Country of origin	PL

EV-T2CCS-PARK - Charging connector holder



1624153

<https://www.phoenixcontact.com/us/products/1624153>

Technical data

Notes

Note on application	Item is not compatible with the HPC CCS type 2 charging cable from Phoenix Contact.
---------------------	---

Product properties

Product type	Charging connector holder
Product family	CHARX connect standard
Type	Accessories
Charging standard	CCS type 2
Charging mode	Mode 4
Customer variations	On request

Dimensions

Bore dimensions

Width	60 mm
Height	103 mm

Material specifications

Color (Housing)	black (9005)
Flammability rating according to UL 94	V0 ()

Mechanical properties

Securing	With locking clips for locking contour
Removal	Lifting and removal

Environmental and real-life conditions

Ambient conditions

Degree of protection	IP54 (plugged in)
Ambient temperature (operation)	-30 °C ... 50 °C
Ambient temperature (storage/transport)	-40 °C ... 80 °C

Standards and regulations

Standards

Standards/regulations	IEC 62196-3
-----------------------	-------------

Mounting

Mounting type Charging connector holder	Front mounting (0° ... 45° frontal inclination possible)
Mounting hole diameter	6.00 mm (ø)

EV-T2CCS-PARK - Charging connector holder

1624153

<https://www.phoenixcontact.com/us/products/1624153>



Drawings

Dimensional drawing

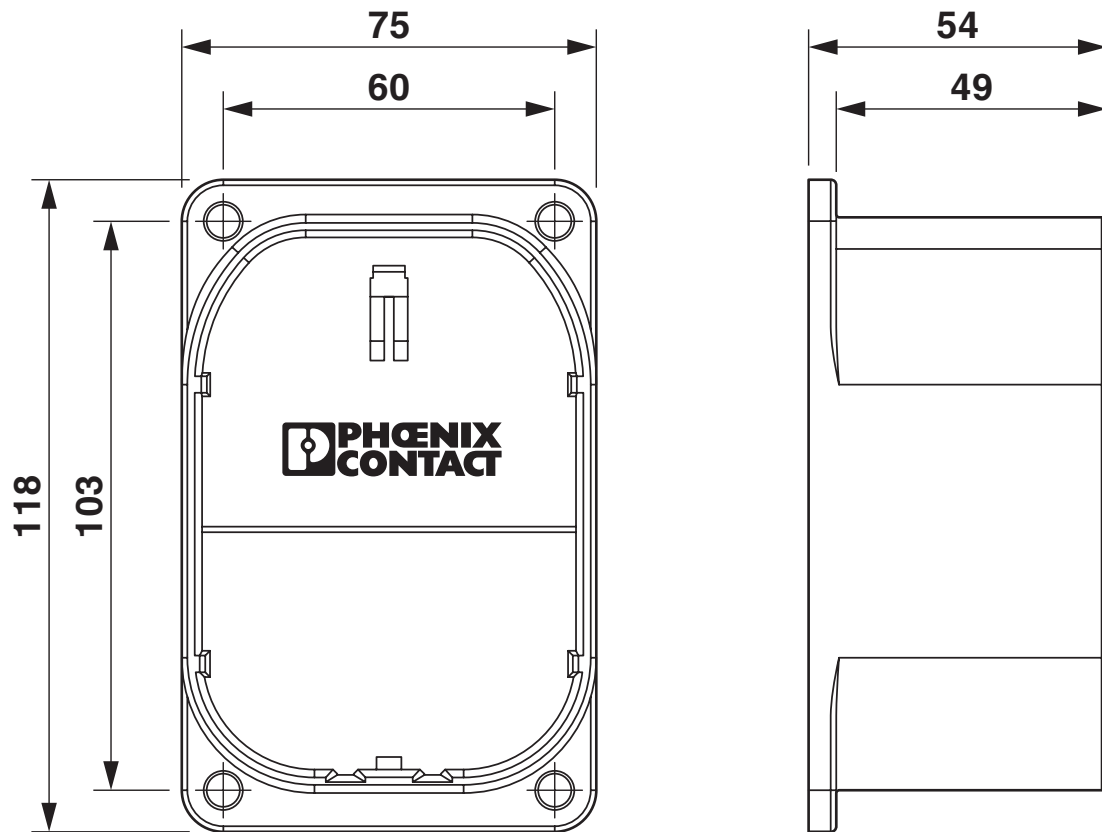

Dimensional drawing

EV-T2CCS-PARK - Charging connector holder

1624153

<https://www.phoenixcontact.com/us/products/1624153>

Schematic diagram

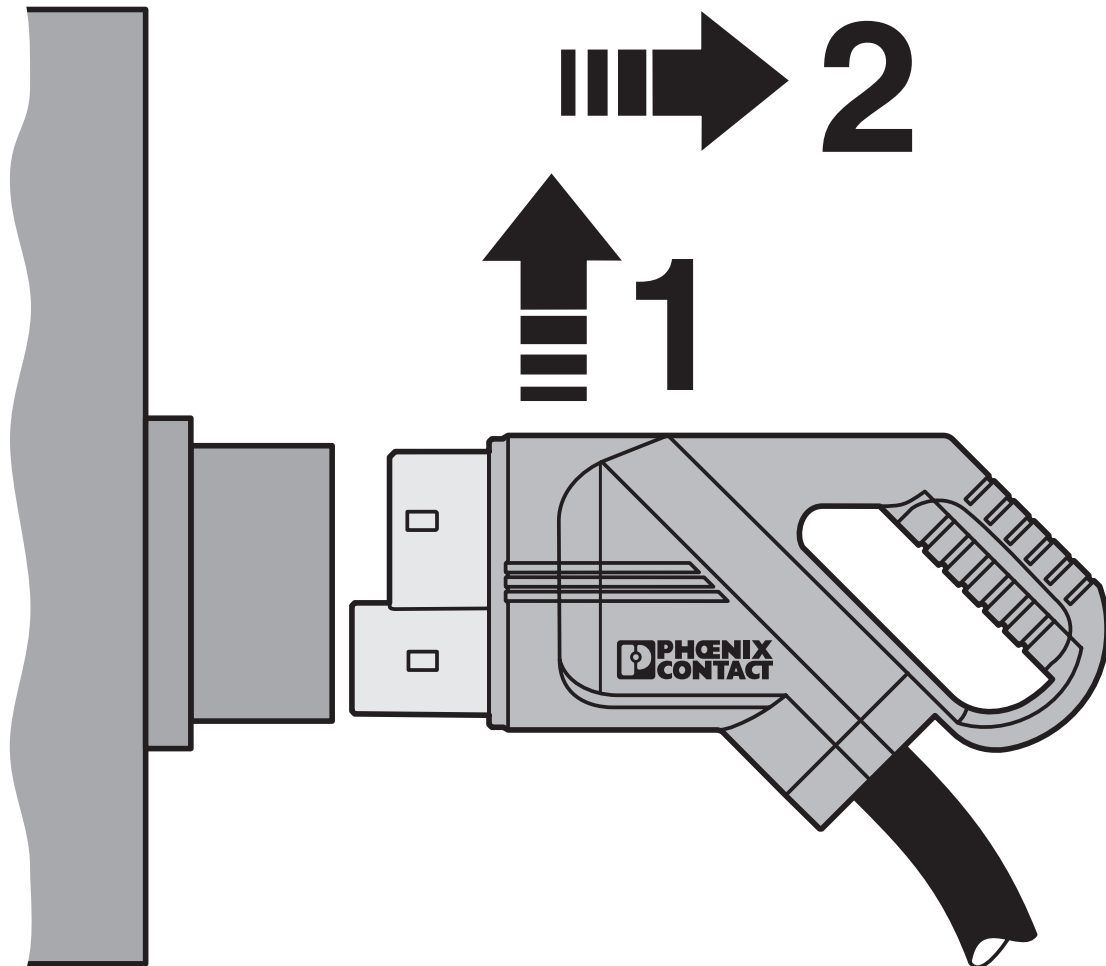

The attached DC Vehicle Connector is raised in the holder, releasing it from the integrated locking clip, and it can then be removed.

EV-T2CCS-PARK - Charging connector holder



1624153

<https://www.phoenixcontact.com/us/products/1624153>

Classifications

ECLASS

ECLASS-13.0	27144792
ECLASS-15.0	27144792

ETIM

ETIM 10.0	EC002884
-----------	----------

UNSPSC

UNSPSC 21.0	39121500
-------------	----------

EV-T2CCS-PARK - Charging connector holder



1624153

<https://www.phoenixcontact.com/us/products/1624153>

Environmental product compliance

EU RoHS

Fulfills EU RoHS substance requirements	Not applicable, No electrical and electronic equipment (EEE), cannot be used in EEE
---	---

EU REACH SVHC

REACH candidate substance (CAS No.)	No substance above 0.1 wt%
-------------------------------------	----------------------------

Phoenix Contact 2026 © - all rights reserved

<https://www.phoenixcontact.com>

Phoenix Contact USA

586 Fulling Mill Road

Middletown, PA 17057, United States

(+717) 944-1300

info@phoenixcon.com