

EV-T1M3C-1AC32A-10M6,0ESBK00 - AC charging cable



1623597

<https://www.phoenixcontact.com/us/products/1623597>

Please be informed that the data shown in this PDF document is generated from our online catalog. Please find the complete data in the user documentation. Our general terms of use for downloads are valid.

CHARX connect, Type 1, cable: 10 m, straight, IEC 62196-2, SAE J1772, AC charging cable with Vehicle Connector, open cable end, with protective cap, NOTE: Signal transmission is dependent on the cable length and may be adversely affected.



Product description

AC charging cable with vehicle charging connector and free cable end for charging electric vehicles (EV) with alternating current (AC) via type 1 vehicle charging inlets, for installation at charging stations for e-mobility (EVSE)

Your advantages

- Consistent design of all Phoenix Contact Vehicle Connectors and Infrastructure Plugs
- Silver-plated surface of the power and signal contacts
- Developed and produced in accordance with the IATF 16949 automotive standard and ISO 9001
- Convenient handling, thanks to the ergonomic handle and additional, rubber grip components

Commercial data

Item number	1623597
Packing unit	1 pc
Minimum order quantity	1 pc
Product key	XWBAAA
GTIN	4055626172026
Weight per piece (including packing)	3,618 g
Weight per piece (excluding packing)	3.53 g
Country of origin	DE

EV-T1M3C-1AC32A-10M6,0ESBK00 - AC charging cable



1623597

<https://www.phoenixcontact.com/us/products/1623597>

Technical data

Product properties

Product type	AC charging cable
Product family	CHARX connect
Charging standard	Type 1
Charging mode	Mode 3, Case C

Electrical properties

Charging power and current (AC charging, 1-phase)

Type of charging current	AC single-phase
Charging current	32 A AC (1-phase)
Charging power	8 kW
Rated voltage	250 V

Cable/line

Cable length	10 m
Wiring standards/regulations	prEN 50620/DIN EN 50620
Wiring certifications	VDE
Cable weight	max. 305.00 kg/km
Cable type	Class 5
Cable type	straight
Cable structure	3 x 6.0 mm ² + 1 x 0.5 mm ²
External cable diameter	12.80 mm ±0.4 mm
Outer sheath, material	TPE-U
Stripping length of the sheath	45 mm ±10 mm
Stripping length	45 mm ±10 mm
Cable resistance	≤ 0.0033 Ω/m (based on a power core, at an ambient temperature of 20°C)
Bending radius	min. 96 mm (7.5x diameter)
Cable length	10 m
Stripping length	45 mm ±10 mm
External cable diameter	12.80 mm ±0.4 mm
Cable type	Class 5
Wiring certifications	VDE
Wiring standards/regulations	prEN 50620/DIN EN 50620
Cable resistance	≤ 0.0033 Ω/m (based on a power core, at an ambient temperature of 20°C)

Standards and regulations

Standards

Standards/regulations	IEC 62196-2
	SAE J1772

EV-T1M3C-1AC32A-10M6,0ESBK00 - AC charging cable

1623597

<https://www.phoenixcontact.com/us/products/1623597>

Drawings

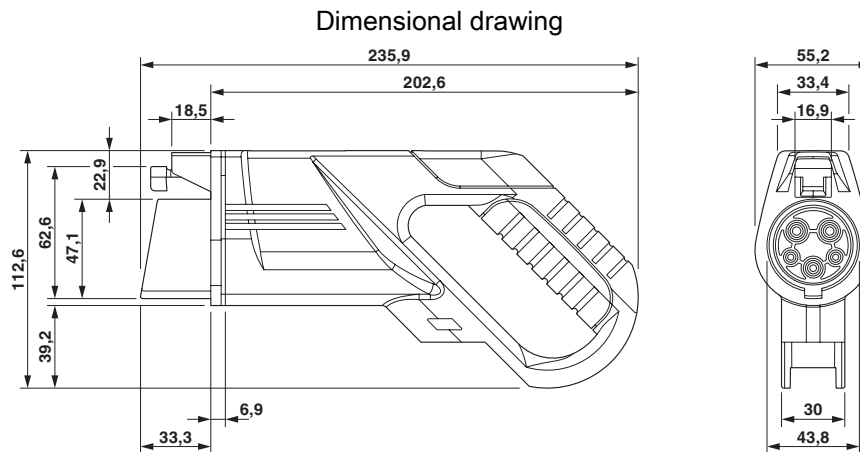

Make sure that the vehicle charging connector is placed in an appropriate charging connector holder, which ensures a minimum protection rating of IP24 in accordance with IEC 61851-1, for the entire time between charging. To create this charging connector holder, use the dimensions of the vehicle charging connector. Detailed dimensions can also be found in the Download area.



Pin assignment of the Vehicle Connector

EV-T1M3C-1AC32A-10M6,0ESBK00 - AC charging cable

1623597

<https://www.phoenixcontact.com/us/products/1623597>

Schematic diagram

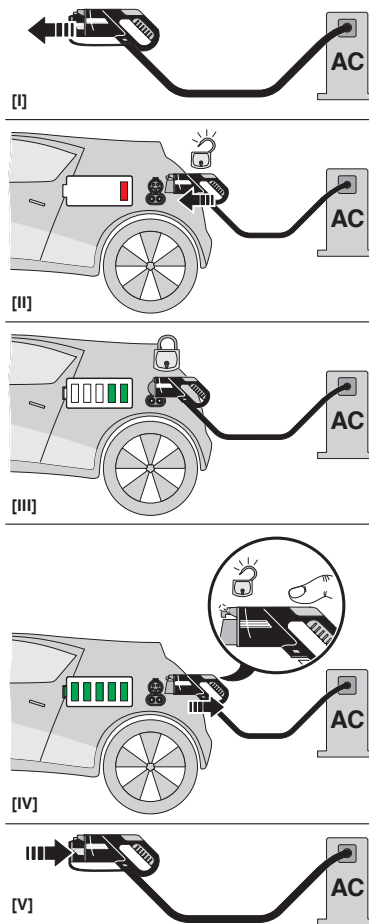

Operating instructions

EV-T1M3C-1AC32A-10M6,0ESBK00 - AC charging cable



1623597

<https://www.phoenixcontact.com/us/products/1623597>

Environmental product compliance

China RoHS

Environment friendly use period (EFUP)	EFUP-10 An article-related China RoHS declaration table can be found in the download area for the respective article under "Manufacturer declaration". For all articles with EFUP-E, no China RoHS declaration table issued and required.
--	--

EU REACH SVHC

REACH candidate substance (CAS No.)	No substance above 0.1 wt%
-------------------------------------	----------------------------

Phoenix Contact 2026 © - all rights reserved
<https://www.phoenixcontact.com>

Phoenix Contact USA
586 Fulling Mill Road
Middletown, PA 17057, United States
(+717) 944-1300
info@phoenixcon.com