

EV-GBSC - Protective cover



1623416

<https://www.phoenixcontact.com/us/products/1623416>

Please be informed that the data shown in this PDF document is generated from our online catalog. Please find the complete data in the user documentation. Our general terms of use for downloads are valid.



CHARX connect basic, GB/T, Type 2, Protective cover, Accessories, circular, Front mounting, housing: black, with self-locking mechanism, for attachment to infrastructure charging sockets, Adhered "PHOENIX CONTACT" sticker, GB/T 20234.2, IEC 62196-2

Product description

Self-closing protective cover for infrastructure charging socket

Your advantages

- Developed and produced in accordance with the IATF 16949 automotive standard and ISO 9001
- Individual branding, thanks to the use your own logo
- Reliable protection of your socket outlet from weather and vandalism

Commercial data

Item number	1623416
Packing unit	1 pc
Minimum order quantity	1 pc
Sales key	EM01
Product key	XWBFAFF
GTIN	4055626242903
Weight per piece (including packing)	50.5 g
Weight per piece (excluding packing)	50.5 g
Customs tariff number	39269097
Country of origin	CN

EV-GBSC - Protective cover



1623416

<https://www.phoenixcontact.com/us/products/1623416>

Technical data

Product properties

Product type	Protective cover for Socket Outlet
Product family	CHARX connect basic
Type	Accessories
Design	with self-locking mechanism
Charging standard	GB/T
	Type 2
Charging mode	Mode 3, Case B
Design (Protective cover)	circular
Affixed logo	Adhered "PHOENIX CONTACT" sticker
Label	14.1 mm x 44.8 mm (customer logo on request)
Customer variations	On request

Dimensions

Protective cover

Dimensional drawing	
Width	76.6 mm
Height	76.6 mm
Depth	24.7 mm

Bore dimensions

Dimensional drawing	
Width	60 mm
Height	60 mm

Material specifications

Color (Housing)	black (9005)
Material (Housing)	Plastic
Flammability rating according to UL 94	V0 ()

Environmental and real-life conditions

EV-GBSC - Protective cover



1623416

<https://www.phoenixcontact.com/us/products/1623416>

Ambient conditions

Degree of protection (Protective cover)	IP54 (plugged in)
Ambient temperature (operation)	-30 °C ... 50 °C
Ambient temperature (storage/transport)	-40 °C ... 80 °C

Standards and regulations

Standards

Standards/regulations	GB/T 20234.2
	IEC 62196-2

Mounting

Mounting type Protective cover	Front mounting (rear screw connection)
Mounting type Infrastructure charging socket	right or left-sided installation
Mounting hole diameter	4.30 mm (ø)

EV-GBSC - Protective cover

1623416

<https://www.phoenixcontact.com/us/products/1623416>

Drawings

Dimensional drawing

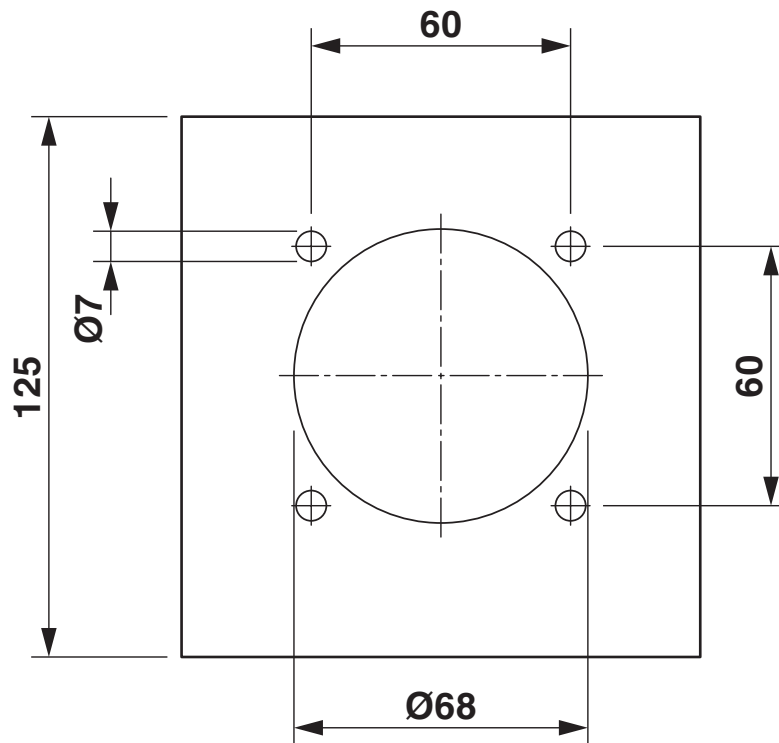

Dimensional drawing

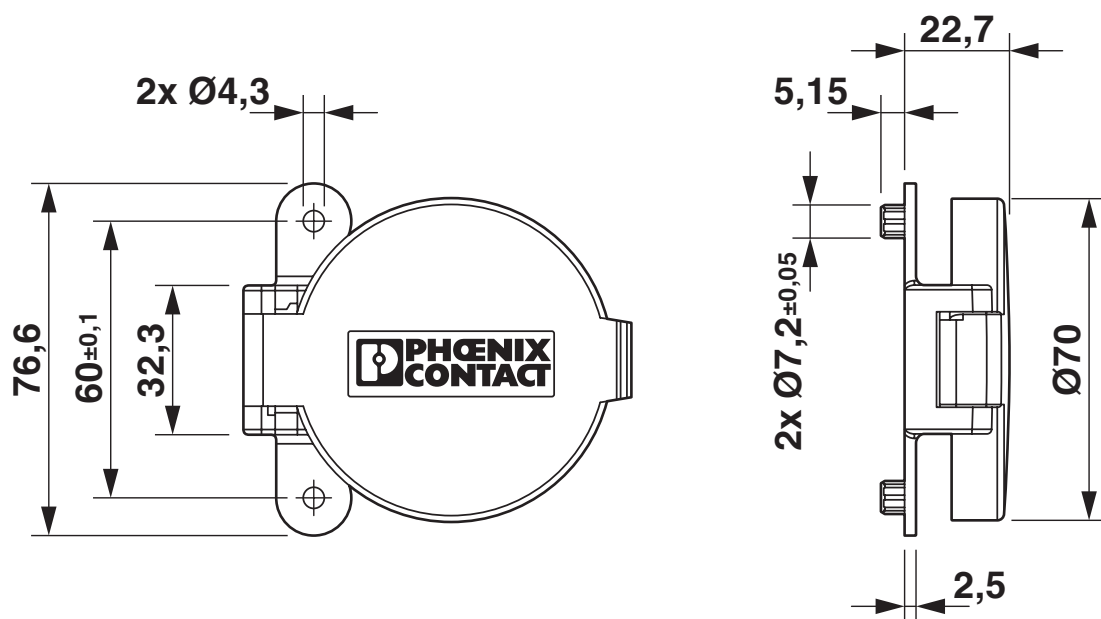

EV-GBSC - Protective cover

1623416

<https://www.phoenixcontact.com/us/products/1623416>

Schematic diagram

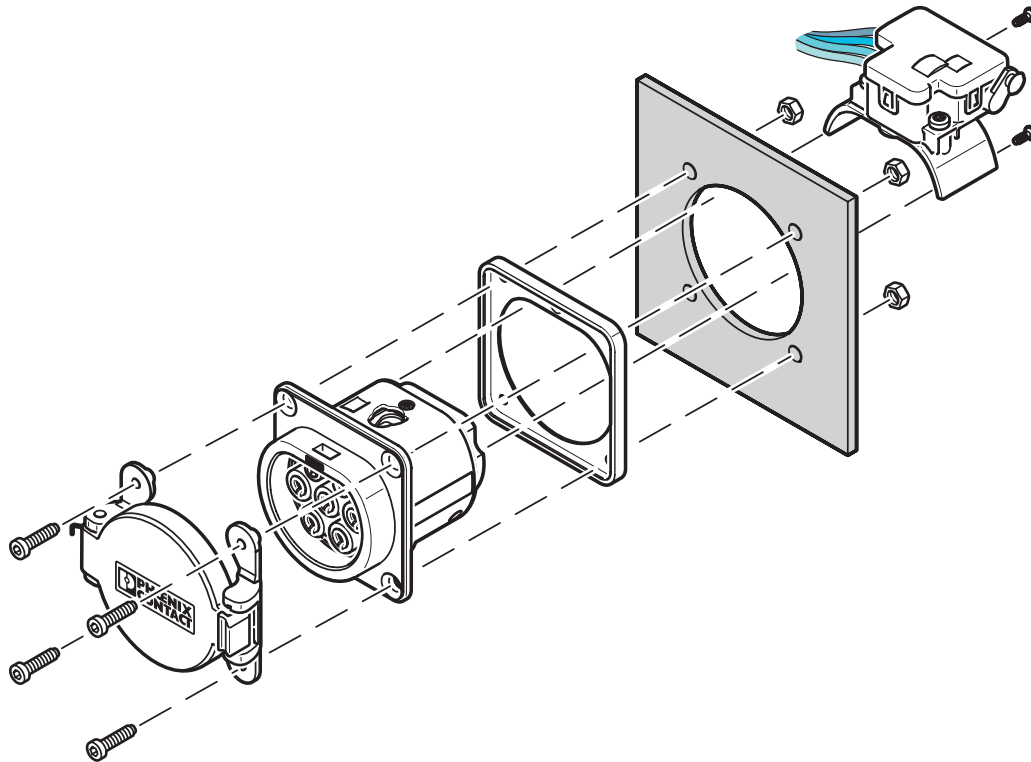

Front mounting with rear protective cover screw connection

Front mounting is only possible when the locking actuator is removed. The screw connection for a protective cover from the accessories range (EV-GBSC...) only supports rear mounting.

EV-GBSC - Protective cover



1623416

<https://www.phoenixcontact.com/us/products/1623416>

Classifications

ECLASS

ECLASS-13.0

27144792

ETIM

ETIM 9.0

EC002884

UNSPSC

UNSPSC 21.0

39121500

EV-GBSC - Protective cover



1623416

<https://www.phoenixcontact.com/us/products/1623416>

Environmental product compliance

EU RoHS

Fulfills EU RoHS substance requirements	Not applicable, No electrical and electronic equipment (EEE), cannot be used in EEE
---	---

EU REACH SVHC

REACH candidate substance (CAS No.)	Lead(CAS: 7439-92-1)
SCIP	e7fcf690-31d6-4bcc-982c-5000017bbf32

Phoenix Contact 2026 © - all rights reserved

<https://www.phoenixcontact.com>

Phoenix Contact USA
586 Fulling Mill Road
Middletown, PA 17057, United States
(+717) 944-1300
info@phoenixcon.com