

# EV-T2M3PC-3AC20A-12M2,5ESBK00 - AC charging cable



1622581

<https://www.phoenixcontact.com/us/products/1622581>

Please be informed that the data shown in this PDF document is generated from our online catalog. Please find the complete data in the user documentation. Our general terms of use for downloads are valid.

CHARX connect, Type 2, cable: 12 m, IEC 62196-2, Mobile AC charging cable with vehicle connector and infrastructure plug, with protective cap, NOTE: The capacitance between CP and PE exceeds the normative guideline value of 1500 pF.



## Product description

Mobile AC charging cable with vehicle charging connector and infrastructure charging plug for charging electric vehicles (EV) with alternating current (AC) via type 2 vehicle charging inlets, compatible with type 2 infrastructure charging sockets at charging stations for e-mobility (EVSE)

## Your advantages

- Consistent design of all Phoenix Contact Vehicle Connectors and Infrastructure Plugs
- Silver-plated surface of the power and signal contacts
- Developed and produced in accordance with the IATF 16949 automotive standard and ISO 9001
- Convenient handling, thanks to the ergonomic handle and additional, rubber grip components

## Commercial data

Item number	1622581
Packing unit	1 pc
Minimum order quantity	1 pc
Product key	XWBAEC
GTIN	4055626046426
Weight per piece (including packing)	22.22 g
Weight per piece (excluding packing)	22.22 g
Country of origin	DE

# EV-T2M3PC-3AC20A-12M2,5ESBK00 - AC charging cable



1622581

<https://www.phoenixcontact.com/us/products/1622581>

## Technical data

### Product properties

Product type	AC charging cable
Product family	CHARX connect
Charging standard	Type 2
Charging mode	Mode 3, Case B

### Electrical properties

#### Charging power and current (AC charging, 3-phase)

Type of charging current	AC 3-phase
Charging current	20 A AC (1-phase)
Charging power	16.63 kW
Rated voltage	440 V

### Cable/line

Cable length	12 m
--------------	------

### Standards and regulations

#### Standards

Standards/regulations	IEC 62196-2
-----------------------	-------------

# EV-T2M3PC-3AC20A-12M2,5ESBK00 - AC charging cable



1622581

<https://www.phoenixcontact.com/us/products/1622581>

## Drawings

Dimensional drawing



Vehicle connector

Dimensional drawing



Infrastructure plug

# EV-T2M3PC-3AC20A-12M2,5ESBK00 - AC charging cable



1622581

<https://www.phoenixcontact.com/us/products/1622581>

Connection diagram

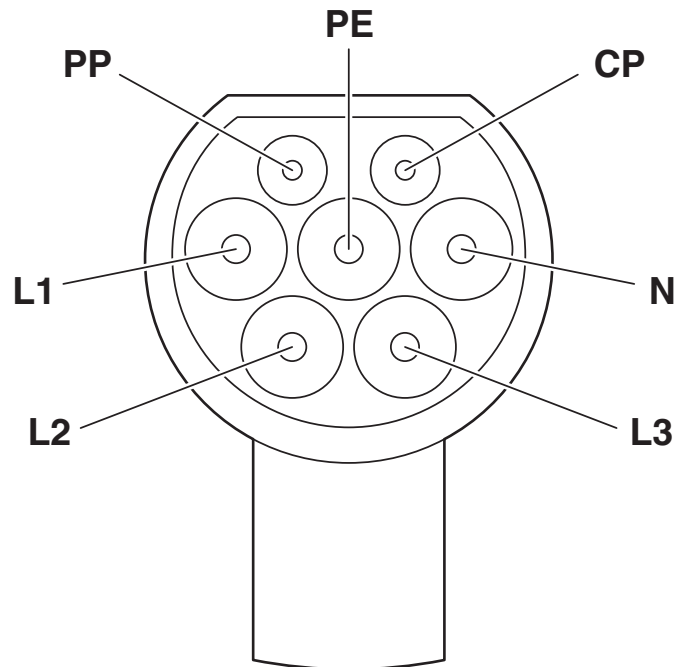

Pin assignment of Infrastructure Plug

# EV-T2M3PC-3AC20A-12M2,5ESBK00 - AC charging cable

1622581

<https://www.phoenixcontact.com/us/products/1622581>

Schematic diagram



Operating instructions

# EV-T2M3PC-3AC20A-12M2,5ESBK00 - AC charging cable

1622581

<https://www.phoenixcontact.com/us/products/1622581>

Schematic diagram

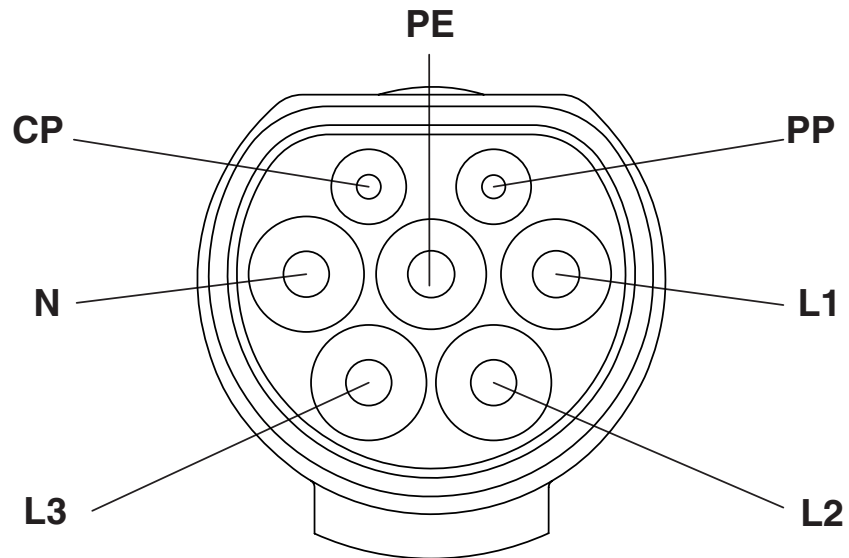

Pin assignment of the Vehicle Connector

# EV-T2M3PC-3AC20A-12M2,5ESBK00 - AC charging cable



1622581

<https://www.phoenixcontact.com/us/products/1622581>

## Classifications

### UNSPSC

UNSPSC 21.0	39121522
-------------	----------

# EV-T2M3PC-3AC20A-12M2,5ESBK00 - AC charging cable



1622581

<https://www.phoenixcontact.com/us/products/1622581>

## Environmental product compliance

### China RoHS

Environment friendly use period (EFUP)	EFUP-10
	An article-related China RoHS declaration table can be found in the download area for the respective article under "Manufacturer declaration". For all articles with EFUP-E, no China RoHS declaration table issued and required.

### EU REACH SVHC

REACH candidate substance (CAS No.)	No substance above 0.1 wt%
-------------------------------------	----------------------------

Phoenix Contact 2026 © - all rights reserved  
<https://www.phoenixcontact.com>

Phoenix Contact USA  
586 Fulling Mill Road  
Middletown, PA 17057, United States  
(+717) 944-1300  
[info@phoenixcon.com](mailto:info@phoenixcon.com)