

CA-17P2NA22S00 - Device connector front mounting



1621362

<https://www.phoenixcontact.com/us/products/1621362>

Please be informed that the data shown in this PDF document is generated from our online catalog. Please find the complete data in the user documentation. Our general terms of use for downloads are valid.



The figure shows the 12-pos. product version with standard contact chamber numbering

M23, Device connector front mounting, application: Signal, series: CA, straight, shielded: yes, for standard and SPEEDCON interlock, No. of pos.: 17, Direction of rotation: Counter direction, contact connection type: Pin, Solder-in connection, Flat gasket, flange dimensions: 25 mm x 25 mm, coding: N

Commercial data

Item number	1621362
Packing unit	1 pc
Minimum order quantity	1 pc
Note	Made to order (non-returnable)
Product key	ABRAEL
GTIN	4046356914833
Weight per piece (including packing)	39.9 g
Weight per piece (excluding packing)	27.67 g
Country of origin	DE

CA-17P2NA22S00 - Device connector front mounting



1621362

<https://www.phoenixcontact.com/us/products/1621362>

Technical data

Product properties

Product type	Circular connectors (device side)
--------------	-----------------------------------

Connector

Insulating body

Coding	N
Connection method	Solder-in connection
Contact switching type	Pin
Application	Signal
Number of positions	17
Direction of rotation	Counter direction
Connection profile	17
Number (Contact group 1)	17
Contact diameter (Contact group 1)	1 mm
Rated current Contact (Contact group 1)	8 A (for max. connection cross section)
Rated voltage Contact (Contact group 1)	48 V AC 74 V DC
Rated surge voltage	1.5 kV
Overvoltage category	III
Degree of pollution	3

Housing

Type	Flange housing
Thread type	M23
Design	straight
Type of locking	for standard and SPEEDCON interlock
Pg screw connection	none
Mounting type	Front mounting/square flange (4x Ø 3.2 mm)
Flange dimensions	25 mm x 25 mm
Material (Housing)	GD-Zn
Degree of protection (plugged in)	IP67
Seal for the device	Flat gasket

CA-17P2NA22S00 - Device connector front mounting



1621362

<https://www.phoenixcontact.com/us/products/1621362>

Drawings

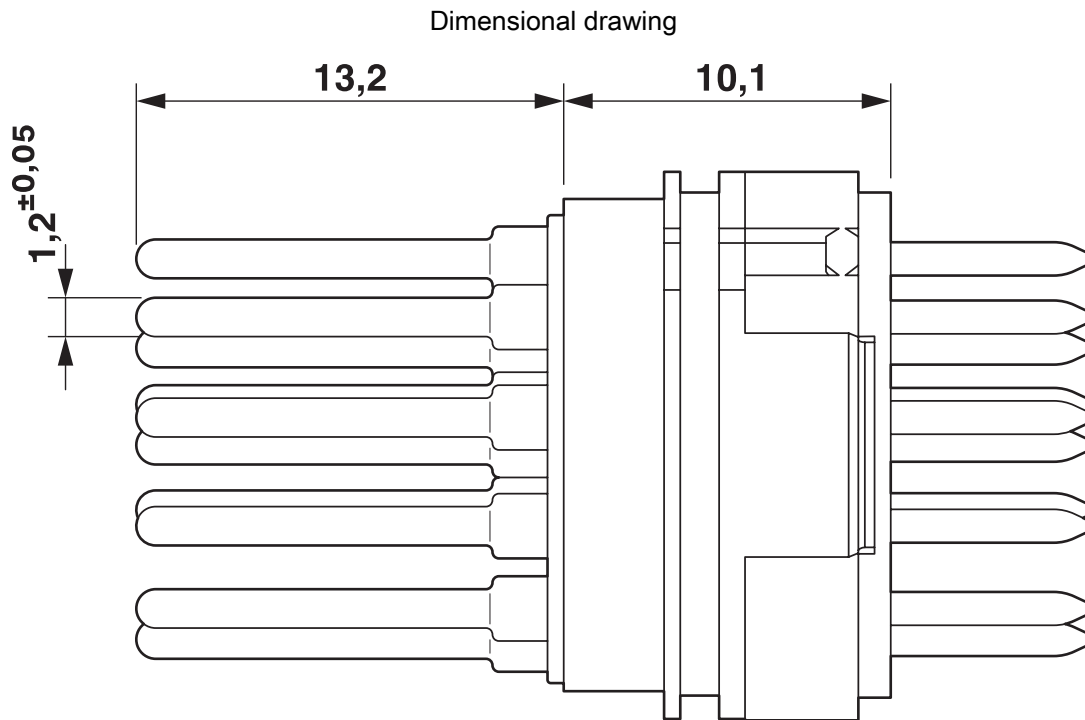

Dimensional drawing

CA-17P2NA22S00 - Device connector front mounting



1621362

<https://www.phoenixcontact.com/us/products/1621362>

Drilling plan/solder pad geometry

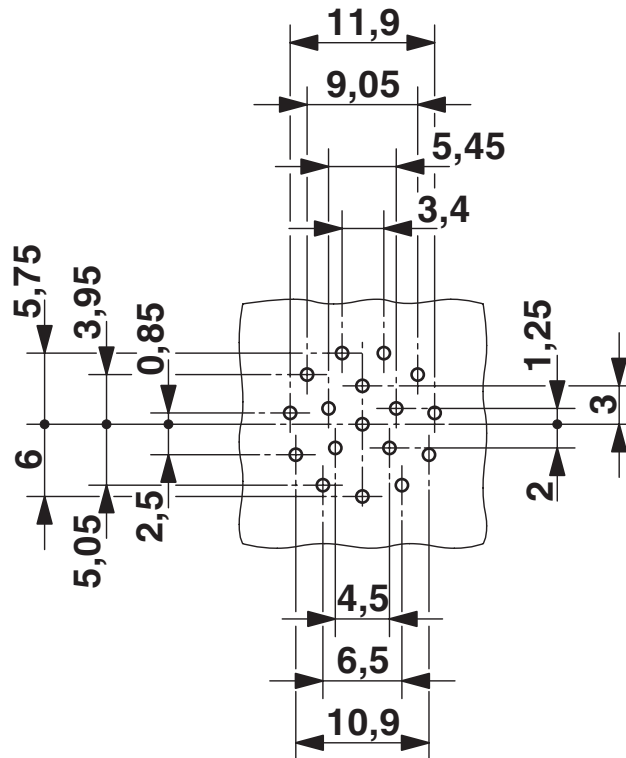

17-pos.

Phoenix Contact 2026 © - all rights reserved
<https://www.phoenixcontact.com>

Phoenix Contact USA
586 Fulling Mill Road
Middletown, PA 17057, United States
(+717) 944-1300
info@phoenixcon.com