

RC-16P1N12C0V5 - Rear panel feed-through



1617657

<https://www.phoenixcontact.com/us/products/1617657>

Please be informed that the data shown in this PDF document is generated from our online catalog. Please find the complete data in the user documentation. Our general terms of use for downloads are valid.



M23, Rear panel feed-through, application: Signal, series: RC, straight, shielded: yes, Screw locking mechanism, No. of pos.: 16, Direction of rotation: Standard, contact connection type: Pin, Solder cup, Flat gasket, Panel thickness max.: 2.5 mm, cable diameter range: 9.5 mm ... 10.5 mm, coding: N

Commercial data

Item number	1617657
Packing unit	20 pc
Minimum order quantity	1 pc
Note	Made to order (non-returnable)
Product key	ABRAFG
GTIN	4046356562126
Weight per piece (including packing)	88.12 g
Weight per piece (excluding packing)	88.12 g
Country of origin	DE

RC-16P1N12C0V5 - Rear panel feed-through



1617657

<https://www.phoenixcontact.com/us/products/1617657>

Technical data

Product properties

Product type	Circular connector (cable-side)
--------------	---------------------------------

Connector

Insulating body

Coding	N
Material (Insulating body)	PBT
Material (Contact)	CuZn
Material (Contact surface)	Ni/Au
Insertion/withdrawal cycles	50
Connection method	Solder cup
Contact switching type	Pin
Application	Signal
Number of positions	16
Direction of rotation	Standard
Connection profile	16
Number (Contact group 1)	16
Contact diameter (Contact group 1)	1 mm
Litz wires Min. cross section (Contact group 1)	0.08 mm ²
Litz wires Max. cross section (Contact group 1)	1 mm ²
Rated current Contact (Contact group 1)	8 A (for max. connection cross section)
Rated voltage Contact (Contact group 1)	48 V AC 74 V DC
Rated surge voltage	1.5 kV
Overvoltage category	III
Degree of pollution	3

Housing

Type	Feed-through header
Thread type	M23
Design	straight
Type of locking	Screw locking mechanism
Pg screw connection	none
Mounting type	Rear mounting/square flange (4x M2,5)
Material (Housing)	GD-Zn
Material (Rotating parts)	CuZn
Material (Housing surface)	Ni
Material (Seal)	FPM (O-ring)
Degree of protection (plugged in)	IP67
Seal for the device	Flat gasket

Seal

RC-16P1N12C0V5 - Rear panel feed-through



1617657

<https://www.phoenixcontact.com/us/products/1617657>

External cable diameter	9.5 mm ... 10.5 mm
-------------------------	--------------------

RC-16P1N12C0V5 - Rear panel feed-through

1617657

<https://www.phoenixcontact.com/us/products/1617657>

Drawings

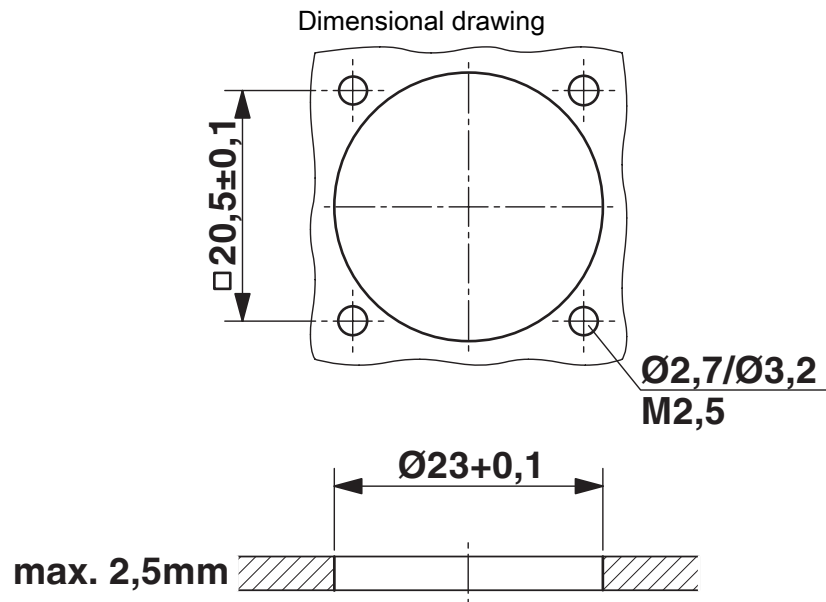

Installation dimensions

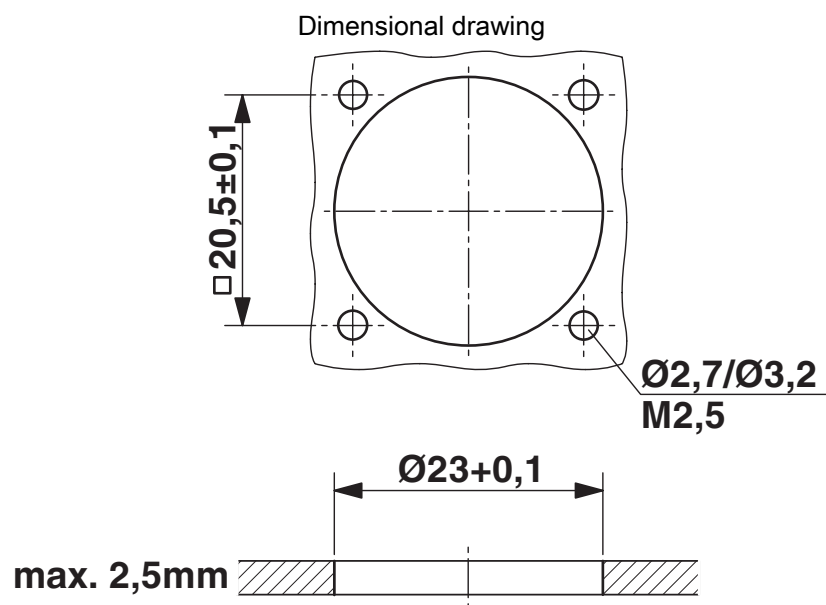

Installation dimensions

RC-16P1N12C0V5 - Rear panel feed-through



1617657

<https://www.phoenixcontact.com/us/products/1617657>

Schematic diagram

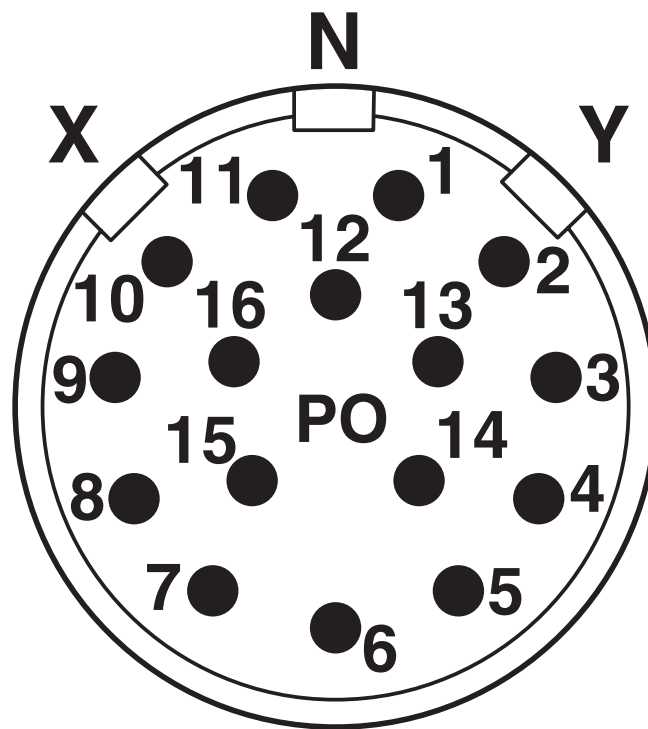

Connector pin assignment

RC-16P1N12C0V5 - Rear panel feed-through



1617657

<https://www.phoenixcontact.com/us/products/1617657>

Schematic diagram



Dimensional drawing

Phoenix Contact 2026 © - all rights reserved
<https://www.phoenixcontact.com>

Phoenix Contact USA
586 Fulling Mill Road
Middletown, PA 17057, United States
(+717) 944-1300
info@phoenixcon.com