

VC-TFS 4-PEA - Contact insert



1607467

<https://www.phoenixcontact.com/us/products/1607467>

Please be informed that the data shown in this PDF document is generated from our online catalog. Please find the complete data in the user documentation. Our general terms of use for downloads are valid.

Contact insert with integrated sleeve frame, type VC 2, 3-pos. + PE, 690 V / 70 A



Your advantages

- Proven COMBICON technology
- Universal connection
- Can be keyed to prevent incorrect connection

Commercial data

Item number	1607467
Packing unit	5 pc
Minimum order quantity	1 pc
Sales key	AB01
Product key	ABLACC
GTIN	4017918969110
Weight per piece (including packing)	57 g
Weight per piece (excluding packing)	42.889 g
Customs tariff number	85366990
Country of origin	PL

Technical data

Notes

General	Connectors may only be connected/disconnected when under no load.
---------	---

Safety note

Safety note	<p>WARNING: The connectors may not be plugged in or disconnected under load. Ignoring the warning or improper use may damage persons and/or property.</p> <ul style="list-style-type: none"> • WARNING: Commission properly functioning products only. The products must be regularly inspected for damage. Decommission defective products immediately. Replace damaged products. Repairs are not possible. • WARNING: Only electrically qualified personnel may install and operate the product. They must observe the following safety notes. The qualified personnel must be familiar with the basics of electrical engineering. They must be able to recognize and prevent danger. The relevant symbol on the packaging indicates that only personnel familiar with electrical engineering are allowed to install and operate the product. • The products are suitable for applications in plant, controller, and electrical device engineering. • When operating the connectors in outdoor applications, they must be separately protected against environmental influences. • Assembled products may not be manipulated or improperly opened. • Only use mating connectors that are specified in the technical data of the standards listed (e.g. the ones listed in the product accessories online at phoenixcontact.com/products). • When using the product in direct connection with third-party manufacturers, the user is responsible. • For operating voltages > 50 V AC, conductive connector housings must be grounded • Ensure that the protective or functional ground has been properly connected. • VDE 0100/1.97 § 411.1.3.2 and DIN EN 60 204/11.98 § 14.1.3 are applicable when combining several circuits in a cable and/or connector • Observe the corresponding technical data. You will find information: <ul style="list-style-type: none"> o On the product o On the packing label o In the supplied documentation o Online at phoenixcontact.com/products under the product • Only use tools recommended by Phoenix Contact • The installation notes/Design In documents online on the download page at phoenixcontact.com/products must be observed for this product. • Use a protective cap to protect connectors that are not in use. The suitable accessories are available online in the accessory section of the product at phoenixcontact.com/products • Operate the connector only when it is fully plugged in.
-------------	---

VC-TFS 4-PEA - Contact insert



1607467

<https://www.phoenixcontact.com/us/products/1607467>

	<ul style="list-style-type: none">• Ensure that when laying the cable, the tensile load on the connectors does not exceed the upper limit specified in the standards.
	<ul style="list-style-type: none">• Observe the minimum bending radius of the cable. Lay the cable without twisting it.
	<ul style="list-style-type: none">• The connector warms up in normal operation. Depending on the ambient conditions, the surface of the connector can continue to warm up. In this case, the user is responsible for posting warnings (e.g. DIN EN ISO 13732-1:2008-12).

Product properties

Product type	Contact insert
Product family	VARIOCON
Series	VC-D
Type	VC2
Number of positions	4
Connection profile	3+PE
Pitch	10.16 mm

Insulation characteristics

Degree of pollution	3
---------------------	---

Electrical properties

Rated voltage (II/2)	1000 V
Rated voltage (III/2)	1000 V
Rated voltage (III/3)	690 V
	690 V
Rated surge voltage	6 kV
Rated surge voltage (II/2)	6 kV
Rated surge voltage (III/2)	8 kV
Rated surge voltage (III/3)	8 kV
Rated surge voltage	6 kV
Rated current	70 A
	70 A
	70 A

Connection data

Connection method	Screw connection
Tightening torque	1.2 ... 1.8 Nm
Cross section AWG	20 ... 6
Screw thread	M4

Dimensions

VC-TFS 4-PEA - Contact insert

1607467

<https://www.phoenixcontact.com/us/products/1607467>

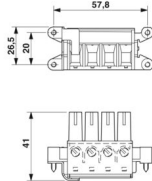
Dimensional drawing	
Width	65.2 mm
Height	27.3 mm
Length	42.8 mm
Pitch	10.16 mm

Material specifications

Color	light gray
Color of the housing part	gray
Material Housing	Polyamide
Material Contact carrier	PA
Material Contact	E-Cu 58
Flammability rating according to UL 94	V0
Insulating material group	I
Contact surface material	hard-silver plated
Material for screw connection	CuZn

Cable/line

Single wire, cross section	0.5 mm ² 16 mm ²
Stripping length of the individual wire	12 mm

Mechanical properties

Mechanical data

Insertion/withdrawal cycles	≥ 50
-----------------------------	------

Environmental and real-life conditions

Ambient conditions

Ambient temperature (operation)	-40 °C ... 100 °C
	when the conductor is connected

VC-TFS 4-PEA - Contact insert

1607467

<https://www.phoenixcontact.com/us/products/1607467>



Drawings

Dimensional drawing

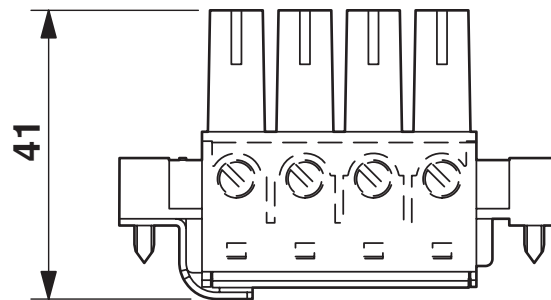
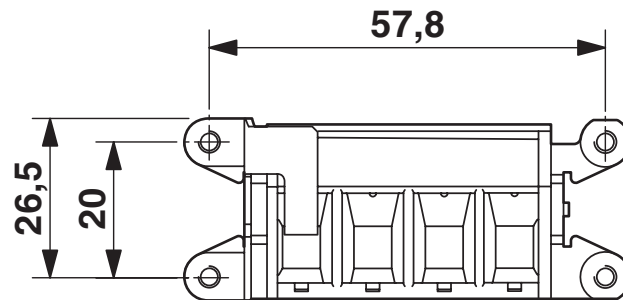

VC-TFS 4-PEA - Contact insert





1607467

<https://www.phoenixcontact.com/us/products/1607467>

Approvals

To download certificates, visit the product detail page: <https://www.phoenixcontact.com/us/products/1607467>

 cUL Recognized Approval ID: E118976				
	Nominal voltage U_N	Nominal current I_N	Cross section AWG	Cross section mm^2
keine				
	600 V	45 A	20 - 6	-

 UL Recognized Approval ID: E118976				
	Nominal voltage U_N	Nominal current I_N	Cross section AWG	Cross section mm^2
keine				
	600 V	55 A	20 - 6	-

VC-TFS 4-PEA - Contact insert



1607467

<https://www.phoenixcontact.com/us/products/1607467>

Classifications

ECLASS

ECLASS-15.0	27440192
ECLASS-13.0	27440192

ETIM

ETIM 10.0	EC002943
-----------	----------

UNSPSC

UNSPSC 21.0	39121400
-------------	----------

VC-TFS 4-PEA - Contact insert



1607467

<https://www.phoenixcontact.com/us/products/1607467>

Environmental product compliance

EU RoHS

Fulfills EU RoHS substance requirements	Yes, No exemptions
---	--------------------

China RoHS

Environment friendly use period (EFUP)	EFUP-E
	No hazardous substances above the limits

EU REACH SVHC

REACH candidate substance (CAS No.)	No substance above 0.1 wt%
-------------------------------------	----------------------------

Phoenix Contact 2026 © - all rights reserved
<https://www.phoenixcontact.com>

Phoenix Contact USA
586 Fulling Mill Road
Middletown, PA 17057, United States
(+717) 944-1300
info@phoenixcon.com