

# HC-B 6-SML-ALUD-74/O2PG21 - Housing



1605527

<https://www.phoenixcontact.com/us/products/1605527>

Please be informed that the data shown in this PDF document is generated from our online catalog. Please find the complete data in the user documentation. Our general terms of use for downloads are valid.



HEAVYCON B6 box mounting base, with single locking latch and cover. Height: 74 mm, with 2 x Pg21 thread.

## Commercial data

|                                      |               |
|--------------------------------------|---------------|
| Item number                          | 1605527       |
| Packing unit                         | 10 pc         |
| Minimum order quantity               | 1 pc          |
| Product key                          | AF7AAC        |
| GTIN                                 | 4017918904050 |
| Weight per piece (including packing) | 454.2 g       |
| Weight per piece (excluding packing) | 454.2 g       |
| Country of origin                    | DE            |

# HC-B 6-SML-ALUD-74/O2PG21 - Housing



1605527

<https://www.phoenixcontact.com/us/products/1605527>

## Technical data

### Product properties

|              |                            |
|--------------|----------------------------|
| Product type | Housing with locking latch |
|--------------|----------------------------|

### Material specifications

|                        |                                 |
|------------------------|---------------------------------|
| Locking latch material | High-grade steel, handle: PA-GF |
|------------------------|---------------------------------|

# HC-B 6-SML-ALUD-74/O2PG21 - Housing

1605527

<https://www.phoenixcontact.com/us/products/1605527>



## Drawings

Dimensional drawing

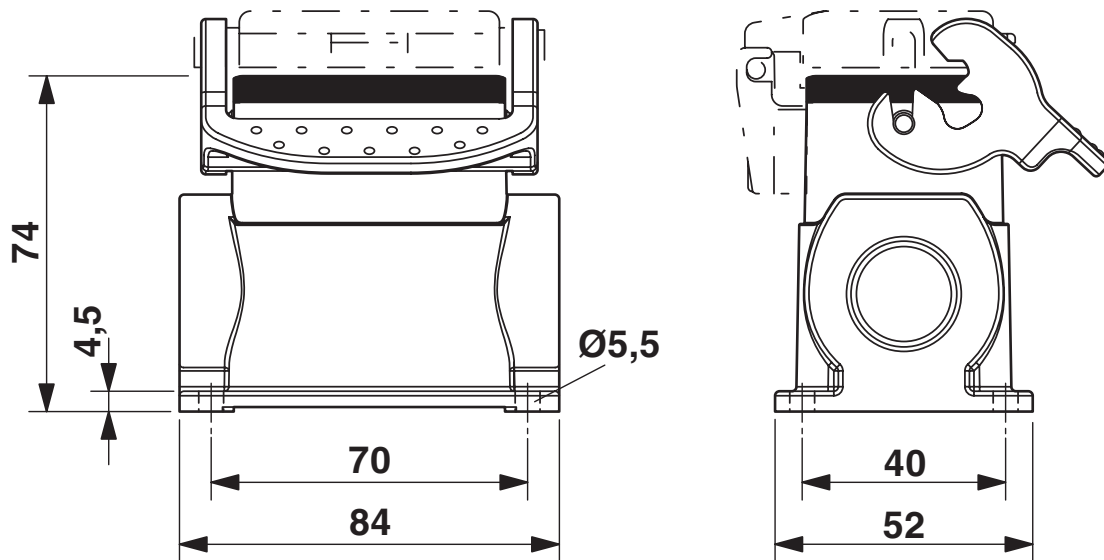

# HC-B 6-SML-ALUD-74/O2PG21 - Housing



1605527

<https://www.phoenixcontact.com/us/products/1605527>

## Approvals

To download certificates, visit the product detail page: <https://www.phoenixcontact.com/us/products/1605527>



**EAC**

Approval ID: RU C-DE.AI30.B.01102

# HC-B 6-SML-ALUD-74/O2PG21 - Housing



1605527

<https://www.phoenixcontact.com/us/products/1605527>

## Classifications

### ECLASS

|             |          |
|-------------|----------|
| ECLASS-13.0 | 27440202 |
| ECLASS-15.0 | 27440202 |

1605527

<https://www.phoenixcontact.com/us/products/1605527>

## Environmental product compliance

### EU RoHS

|   |                    |
|---|--------------------|
| Fulfills EU RoHS substance requirements | Yes, No exemptions |
|---|--------------------|

### China RoHS

|  |  |
|--|--|
| Environment friendly use period (EFUP) | EFUP-E                                   |
|  | No hazardous substances above the limits |

### EU REACH SVHC

|                                     |                            |
|-------------------------------------|----------------------------|
| REACH candidate substance (CAS No.) | No substance above 0.1 wt% |
|-------------------------------------|----------------------------|

Phoenix Contact 2026 © - all rights reserved  
<https://www.phoenixcontact.com>

Phoenix Contact USA  
586 Fulling Mill Road  
Middletown, PA 17057, United States  
(+717) 944-1300  
[info@phoenixcon.com](mailto:info@phoenixcon.com)