

HC-B 16-AMQ-A - Housing

1605200

<https://www.phoenixcontact.com/us/products/1605200>

Please be informed that the data shown in this PDF document is generated from our online catalog. Please find the complete data in the user documentation. Our general terms of use for downloads are valid.



HEAVYCON panel mounting base B16, with double locking latch made of sheet steel, height 27 mm, with flat gasket

Commercial data

Item number	1605200
Packing unit	1 pc
Note	Made to order (non-returnable)
Sales key	BF55
Product key	AF7AAC
GTIN	4017918887278
Weight per piece (including packing)	157.51 g
Weight per piece (excluding packing)	157.51 g
Customs tariff number	85389099
Country of origin	DE

HC-B 16-AMQ-A - Housing

1605200

<https://www.phoenixcontact.com/us/products/1605200>

Technical data

Product properties

Product type	Housing with locking latch
Housing type	Panel mounting base
Type	B16
Shielded	no
Pg screw connection	none

Dimensions

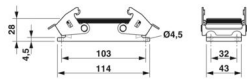
Dimensional drawing	
Width	43 mm
Height	28 mm
Length	114 mm

Installation dimensions

Width of the assembly cutout	35 mm
Length of the assembly cutout	86 mm

Material specifications

Seal material	NBR CR
Housing material	Die-cast aluminum
Housing surface material	Powder-coated, gray
Locking latch material	Steel, galvanized

Connection data

Tightening torque	1.5 Nm ... 2 Nm (Mounting screw)
-------------------	----------------------------------

Environmental and real-life conditions

Ambient conditions

Degree of protection	IP65 (When plugged in)
Ambient temperature (operation)	-40 °C ... 125 °C

HC-B 16-AMQ-A - Housing

1605200

<https://www.phoenixcontact.com/us/products/1605200>

Drawings

Dimensional drawing

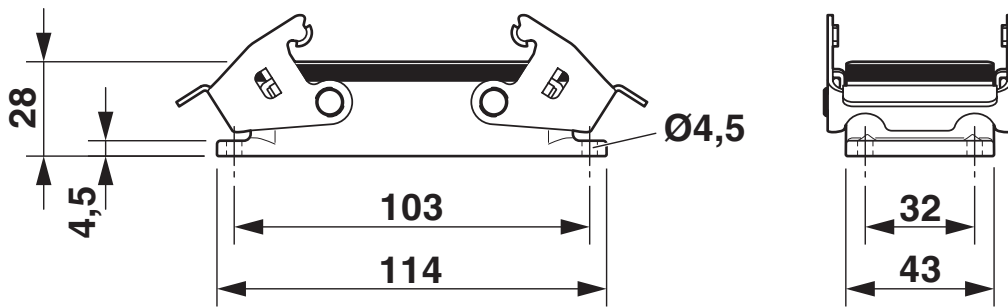

Dimensional drawing

Dimensional drawing

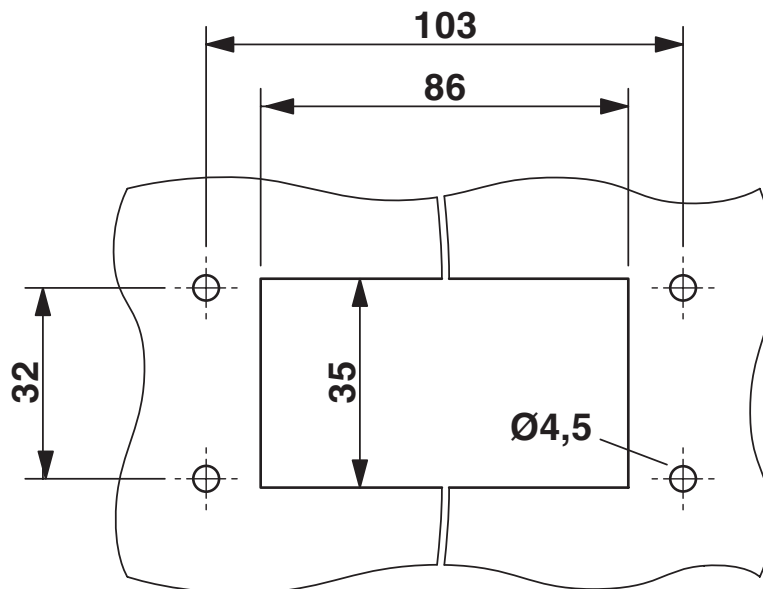

Mounting cutout

HC-B 16-AMQ-A - Housing

1605200

<https://www.phoenixcontact.com/us/products/1605200>



Classifications

ECLASS

ECLASS-13.0	27440202
ECLASS-15.0	27440202

HC-B 16-AMQ-A - Housing



1605200

<https://www.phoenixcontact.com/us/products/1605200>

Environmental product compliance

China RoHS

Environment friendly use period (EFUP)	EFUP-E
	No hazardous substances above the limits

EU REACH SVHC

REACH candidate substance (CAS No.)	No substance above 0.1 wt%
-------------------------------------	----------------------------

Phoenix Contact 2026 © - all rights reserved
<https://www.phoenixcontact.com>

Phoenix Contact USA
586 Fulling Mill Road
Middletown, PA 17057, United States
(+717) 944-1300
info@phoenixcon.com