

HC-HV 6-TFQ-45/O1M25G - Housing



1604935

<https://www.phoenixcontact.com/us/products/1604935>

Please be informed that the data shown in this PDF document is generated from our online catalog. Please find the complete data in the user documentation. Our general terms of use for downloads are valid.



HEAVYCON sleeve housing HV6, for double locking latch, height 45 mm, with support 1x M25, straight conductor exit

Commercial data

Item number	1604935
Packing unit	1 pc
Note	Made to order (non-returnable)
Sales key	BF60
Product key	AF7AAB
GTIN	4017918883102
Weight per piece (including packing)	223 g
Weight per piece (excluding packing)	223 g
Customs tariff number	85389099
Country of origin	DE

HC-HV 6-TFQ-45/O1M25G - Housing

1604935

<https://www.phoenixcontact.com/us/products/1604935>

Technical data

Product properties

Product type	Housing with locking latch
Housing type	Sleeve housing
Application	Standard
Type	HV6
No. of cable outlets	1
Type of the screw connection	1x M25
Cable outlet	straight

Dimensions

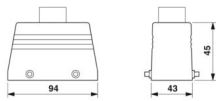
Dimensional drawing	
Width	43 mm
Height	65 mm
Length	94 mm

Material specifications

Housing material	Die-cast aluminum
Housing surface material	Powder-coated, gray

Mechanical properties

Mechanical data

Type of the screw connection	1x M25
------------------------------	--------

Environmental and real-life conditions

Ambient conditions

Degree of protection	IP65
Ambient temperature (operation)	-40 °C ... 125 °C

HC-HV 6-TFQ-45/O1M25G - Housing



1604935

<https://www.phoenixcontact.com/us/products/1604935>

Drawings

Dimensional drawing

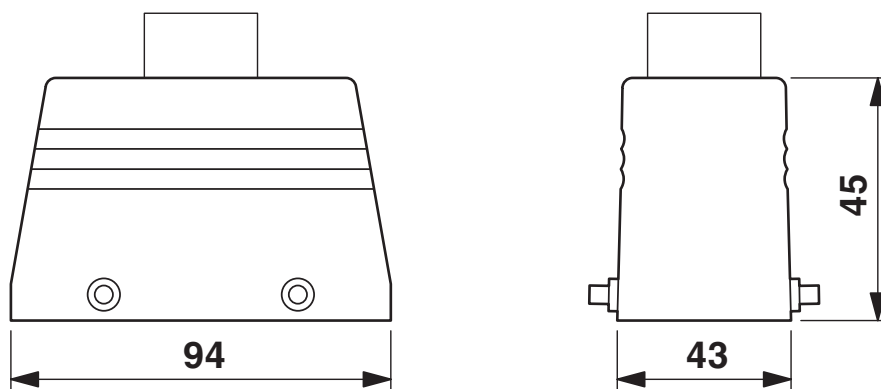

Dimensional drawing

HC-HV 6-TFQ-45/O1M25G - Housing



1604935

<https://www.phoenixcontact.com/us/products/1604935>

Classifications

ECLASS

ECLASS-13.0	27440202
ECLASS-15.0	27440202

HC-HV 6-TFQ-45/O1M25G - Housing



1604935

<https://www.phoenixcontact.com/us/products/1604935>

Environmental product compliance

EU RoHS

Fulfills EU RoHS substance requirements	Yes, No exemptions
---	--------------------

China RoHS

Environment friendly use period (EFUP)	EFUP-E
	No hazardous substances above the limits

EU REACH SVHC

REACH candidate substance (CAS No.)	No substance above 0.1 wt%
-------------------------------------	----------------------------

Phoenix Contact 2026 © - all rights reserved
<https://www.phoenixcontact.com>

Phoenix Contact USA
586 Fulling Mill Road
Middletown, PA 17057, United States
(+717) 944-1300
info@phoenixcon.com