

# HC-B-BF - Panel-mount flange

1604641

<https://www.phoenixcontact.com/us/products/1604641>

Please be informed that the data shown in this PDF document is generated from our online catalog. Please find the complete data in the user documentation. Our general terms of use for downloads are valid.

Panel mounting flange for HEAVYCON ADVANCE TMB housing with bayonet locking



## Commercial data

Item number	1604641
Packing unit	20 pc
Minimum order quantity	20 pc
Sales key	BF66
Product key	AF7AAZ
GTIN	4017918947811
Weight per piece (including packing)	27.855 g
Weight per piece (excluding packing)	10 g
Customs tariff number	85389099
Country of origin	CN

# HC-B-BF - Panel-mount flange

1604641

<https://www.phoenixcontact.com/us/products/1604641>

## Technical data

### Product properties

Product type	Panel-mount flange
Pg screw connection	none

### Dimensions

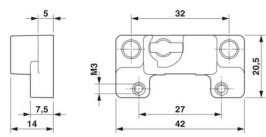
Dimensional drawing	
Hole diameter	4.5 mm

### Material specifications

Material	Die-cast zinc
----------	---------------

### Mechanical properties

#### Mechanical data

Locking type	Nut
--------------	-----

### Environmental and real-life conditions

#### Ambient conditions

Ambient temperature (operation)	-40 °C ... 125 °C
---------------------------------	-------------------

### Mounting

Assembly note	In order to guarantee that the protective conductor contact functions even when plugged in at an angle, the two panel-mount flanges must have sufficient electrical contact with the metal mounting panel.
---------------	--

# HC-B-BF - Panel-mount flange



1604641

<https://www.phoenixcontact.com/us/products/1604641>

## Drawings

Dimensional drawing

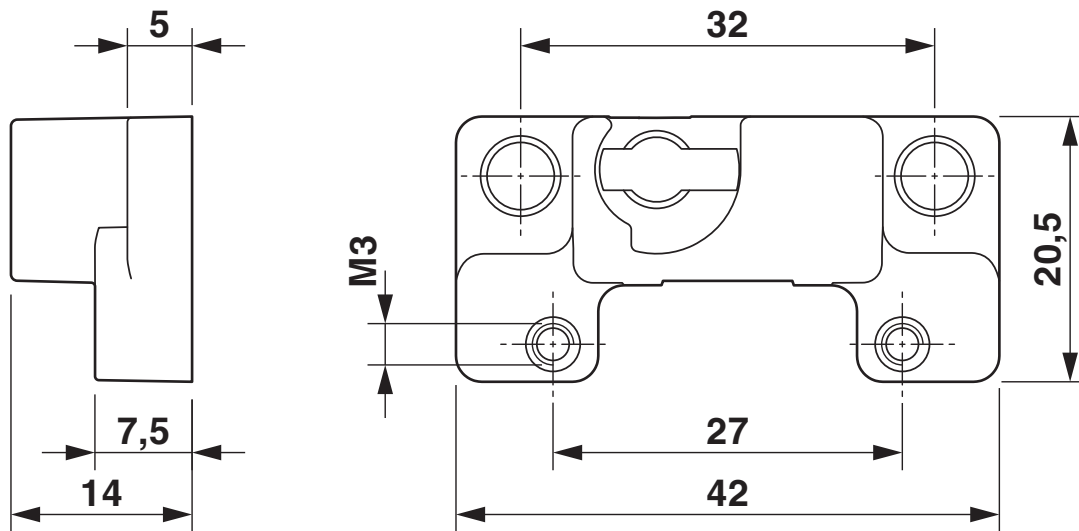

Dimensional drawing

# HC-B-BF - Panel-mount flange



1604641

<https://www.phoenixcontact.com/us/products/1604641>

## Approvals

To download certificates, visit the product detail page: <https://www.phoenixcontact.com/us/products/1604641>



**EAC**

Approval ID: RU C-DE.AI30.B.01102

# HC-B-BF - Panel-mount flange



1604641

<https://www.phoenixcontact.com/us/products/1604641>

## Classifications

### ECLASS

ECLASS-13.0	27440192
ECLASS-15.0	27440192

### ETIM

ETIM 10.0	EC002943
-----------	----------

### UNSPSC

UNSPSC 21.0	39121400
-------------	----------

# HC-B-BF - Panel-mount flange



1604641

<https://www.phoenixcontact.com/us/products/1604641>

## Environmental product compliance

### EU RoHS

Fulfills EU RoHS substance requirements	Yes, No exemptions
---	--------------------

### China RoHS

Environment friendly use period (EFUP)	EFUP-E
	No hazardous substances above the limits

### EU REACH SVHC

REACH candidate substance (CAS No.)	No substance above 0.1 wt%
-------------------------------------	----------------------------

Phoenix Contact 2026 © - all rights reserved  
<https://www.phoenixcontact.com>

Phoenix Contact USA  
586 Fulling Mill Road  
Middletown, PA 17057, United States  
(+717) 944-1300  
[info@phoenixcon.com](mailto:info@phoenixcon.com)