

HC-B 6-TMB-100/O1STM25S-EMV - EMC housing



1604243

<https://www.phoenixcontact.com/us/products/1604243>

Please be informed that the data shown in this PDF document is generated from our online catalog. Please find the complete data in the user documentation. Our general terms of use for downloads are valid.



HEAVYCON ADVANCE EMV sleeve housing B6, with bayonet locking, height 100 mm, with 1xM25 thread, lateral cable outlet

Commercial data

Item number	1604243
Packing unit	10 pc
Minimum order quantity	1 pc
Sales key	BF58
Product key	AF7AAA
GTIN	4017918947927
Weight per piece (including packing)	317.63 g
Weight per piece (excluding packing)	307.12 g
Customs tariff number	85389099
Country of origin	DE

1604243

<https://www.phoenixcontact.com/us/products/1604243>

Technical data

Product properties

Product type	Housing with bayonet locking
Housing type	Sleeve housing
Application	EMC
Type	B6
No. of cable outlets	1
Type of the screw connection	1x M25
Cable outlet	lateral

Dimensions

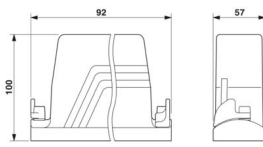
Dimensional drawing	
Width	57 mm
Height	100 mm
Length	92 mm

Installation dimensions

Width of the assembly cutout	35 mm
Length of the assembly cutout	52 mm

Material specifications

Seal material	NBR, conductive
Housing material	Die-cast aluminum
Housing surface material	Powder coating
Locking latch material	High-grade steel, handle: PA-GF

Environmental and real-life conditions

Ambient conditions

Degree of protection	IP65
	IP67
Ambient temperature (operation)	-40 °C ... 125 °C

Mechanical properties

Mechanical data

Type of the screw connection	1x M25
Locking type	Screw

Mounting

1604243

<https://www.phoenixcontact.com/us/products/1604243>

Assembly note

In order to guarantee that the protective conductor contact functions even when plugged in at an angle, the two panel-mount flanges must have sufficient electrical contact with the metal mounting panel.

If insulating powder coating is present on the control cabinet panel, it should be removed from the profile gasket area in order to ensure optimum shielding.

1604243

<https://www.phoenixcontact.com/us/products/1604243>

Drawings

Dimensional drawing



Dimensional drawing

Dimensional drawing



Mounting cutout

1) when M4 screws are used

2) when self-tapping Torx® screws are used (Torx® 20, M4)

HC-B 6-TMB-100/O1STM25S-EMV - EMC housing



1604243

<https://www.phoenixcontact.com/us/products/1604243>

Approvals

To download certificates, visit the product detail page: <https://www.phoenixcontact.com/us/products/1604243>



EAC

Approval ID: RU C-DE.AI30.B.01102

1604243

<https://www.phoenixcontact.com/us/products/1604243>

Classifications

ECLASS

ECLASS-13.0	27440202
ECLASS-15.0	27440202

ETIM

ETIM 10.0	EC000437
-----------	----------

UNSPSC

UNSPSC 21.0	31261500
-------------	----------

1604243

<https://www.phoenixcontact.com/us/products/1604243>

Environmental product compliance

EU RoHS

Fulfills EU RoHS substance requirements	Yes, No exemptions
---	--------------------

China RoHS

Environment friendly use period (EFUP)	EFUP-E
	No hazardous substances above the limits

EU REACH SVHC

REACH candidate substance (CAS No.)	No substance above 0.1 wt%
-------------------------------------	----------------------------

EF3.1 Climate Change

CO2e kg	2.442 kg CO2e
---------	---------------

Phoenix Contact 2026 © - all rights reserved
<https://www.phoenixcontact.com>

Phoenix Contact USA
586 Fulling Mill Road
Middletown, PA 17057, United States
(+717) 944-1300
info@phoenixcon.com