

RC-0000000B2FZ - Front panel feed-through



1592781

<https://www.phoenixcontact.com/us/products/1592781>

Please be informed that the data shown in this PDF document is generated from our online catalog. Please find the complete data in the user documentation. Our general terms of use for downloads are valid.



Front panel feed-through, series: RC, straight, Screw locking mechanism, M23, number of positions: 12, contact connection type: Socket, Crimp connection, Radial O-ring, shielded: yes, panel thickness min.: 3 mm, panel thickness max.: 7 mm, cable diameter range: 2 mm... 10.5 mm. This product is in the process of being discontinued. This product must no longer be considered for new projects. Please contact your sales representative for alternatives.

Commercial data

Item number	1592781
Packing unit	20 pc
Minimum order quantity	1 pc
Sales key	AB31
Product key	ABRAFK
GTIN	4046356192743
Weight per piece (including packing)	69.945 g
Weight per piece (excluding packing)	65.47 g
Customs tariff number	85366990
Country of origin	DE

RC-0000000B2FZ - Front panel feed-through



1592781

<https://www.phoenixcontact.com/us/products/1592781>

Technical data

Product properties

Product type	Circular connector housing
Series	RC
Application	Signal
Connection profile	12
Shielded	yes
Thread type	M23

Connection data

Connection method	Crimp connection
-------------------	------------------

Dimensions

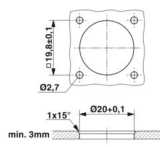
Dimensional drawing	
Panel thickness	3 mm ... 7 mm

Material specifications

Material Housing	GD-Zn
Material Rotating parts	CuZn
Seal material	FPM or NBR or EPDM
Housing material	Turned parts: copper zinc alloy (CuZn), die-cast parts: zinc (GD-Zn)
Gasket and O-ring material	FPM

Connector

Type	straight
------	----------

Cable/line

External cable diameter	2 mm ... 10.5 mm
-------------------------	------------------

Environmental and real-life conditions

Ambient conditions

Degree of protection	IP67
Ambient temperature (operation)	-20 °C ... 125 °C
Altitude	2000 m

Mounting

Mounting type	Front mounting/square flange (4x Ø 2.7 mm)
---------------	--

RC-0000000B2FZ - Front panel feed-through

1592781

<https://www.phoenixcontact.com/us/products/1592781>

Drawings

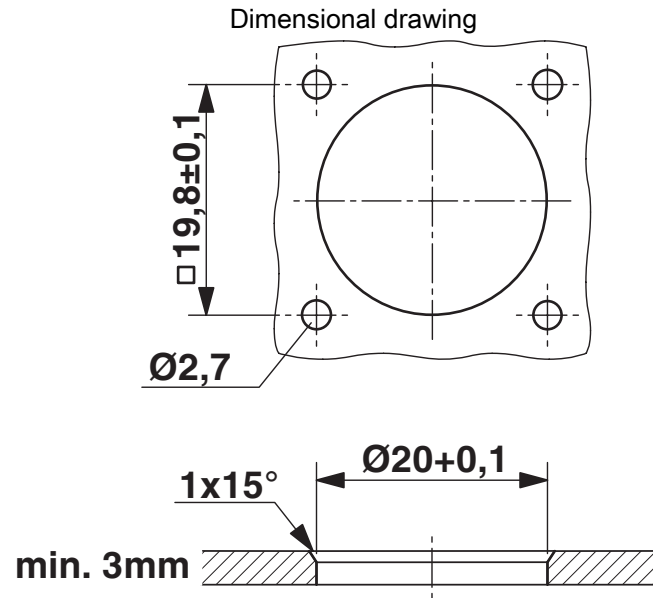

Installation dimensions

RC-0000000B2FZ - Front panel feed-through



1592781

<https://www.phoenixcontact.com/us/products/1592781>

Classifications

ECLASS

ECLASS-13.0	27440224
ECLASS-15.0	27440224

ETIM

ETIM 10.0	EC003556
-----------	----------

UNSPSC

UNSPSC 21.0	39121400
-------------	----------

1592781

<https://www.phoenixcontact.com/us/products/1592781>

Environmental product compliance

EU RoHS

Fulfills EU RoHS substance requirements	Yes
Exemption	6(c)

China RoHS

Environment friendly use period (EFUP)	EFUP-50
	An article-related China RoHS declaration table can be found in the download area for the respective article under "Manufacturer declaration". For all articles with EFUP-E, no China RoHS declaration table issued and required.

EU REACH SVHC

REACH candidate substance (CAS No.)	Lead(CAS: 7439-92-1)
SCIP	2f674cce-5ae7-480f-9bd3-be58ebb10b51

Phoenix Contact 2026 © - all rights reserved

<https://www.phoenixcontact.com>

Phoenix Contact USA
586 Fulling Mill Road
Middletown, PA 17057, United States
(+717) 944-1300
info@phoenixcon.com