

HC-M-08-GBIT-MOD-ST - Contact insert module



1587690

<https://www.phoenixcontact.com/us/products/1587690>

Please be informed that the data shown in this PDF document is generated from our online catalog. Please find the complete data in the user documentation. Our general terms of use for downloads are valid.

Plug module for Gigabit connector (8-pos.; for CAT5)



Commercial data

Item number	1587690
Packing unit	1 pc
Note	Made to order (non-returnable)
Sales key	BF62
Product key	AF7ACB
GTIN	4046356528276
Weight per piece (including packing)	10.2 g
Weight per piece (excluding packing)	10.2 g
Customs tariff number	85389099
Country of origin	DE

HC-M-08-GBIT-MOD-ST - Contact insert module



1587690

<https://www.phoenixcontact.com/us/products/1587690>

Technical data

Product properties

Series	HC-M-08-GBIT
Connection profile	8
Number of module slots	1
Number of slots	1

Dimensions

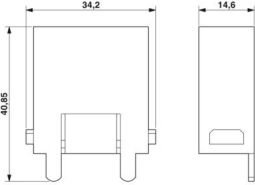
Dimensional drawing	
Width	34.2 mm
Height	40.85 mm
Length	14.6 mm

Material specifications

Flammability rating according to UL 94	V0
Contact carrier material	PC

Mechanical properties

Mechanical data

Insertion/withdrawal cycles	≥ 500
-----------------------------	-------

Environmental and real-life conditions

Ambient conditions

Ambient temperature (operation)	-40 °C ... 85 °C (including heating up of contacts)
---------------------------------	---

Mounting

Assembly note	Module for Order No. 1587713
---------------	------------------------------

HC-M-08-GBIT-MOD-ST - Contact insert module



1587690

<https://www.phoenixcontact.com/us/products/1587690>

Drawings

Dimensional drawing

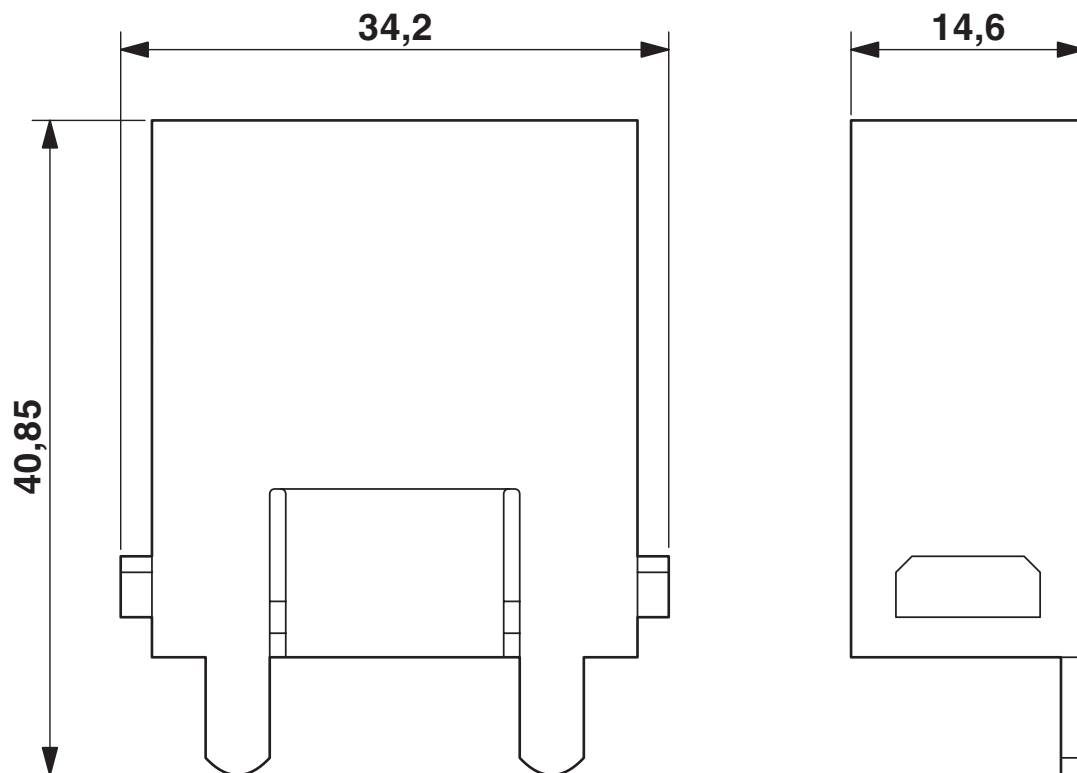

Male insert

HC-M-08-GBIT-MOD-ST - Contact insert module



1587690

<https://www.phoenixcontact.com/us/products/1587690>

Environmental product compliance

China RoHS

Environment friendly use period (EFUP)	EFUP-E
	No hazardous substances above the limits

EU REACH SVHC

REACH candidate substance (CAS No.)	No substance above 0.1 wt%
-------------------------------------	----------------------------

Phoenix Contact 2026 © - all rights reserved
<https://www.phoenixcontact.com>

Phoenix Contact USA
586 Fulling Mill Road
Middletown, PA 17057, United States
(+717) 944-1300
info@phoenixcon.com