

CK2,5-ED-0,5ST FE - Crimp contact



1585760

<https://www.phoenixcontact.com/us/products/1585760>

Please be informed that the data shown in this PDF document is generated from our online catalog. Please find the complete data in the user documentation. Our general terms of use for downloads are valid.



Crimp contact, series: HC-M-06; HC-M-HV; HC-M-08; HC-A; HC-BB; HC-B; HC-HV, Pin, turned, contact diameter: 2.5 mm, rated current: 16 A, contact material: Iron

Commercial data

Item number	1585760
Packing unit	25 pc
Minimum order quantity	25 pc
Sales key	BF65
Product key	AF7AID
GTIN	4046356308267
Weight per piece (including packing)	1.272 g
Weight per piece (excluding packing)	1.213 g
Customs tariff number	85366990
Country of origin	DE

CK2,5-ED-0,5ST FE - Crimp contact



1585760

<https://www.phoenixcontact.com/us/products/1585760>

Technical data

Notes

General	For HC-M-06, HC-M-HV, HC-M-08, HC-A, HC-BB, HC-B and HC-HV contact inserts, the quality of a crimp connection is determined by the DIN EN 60 352-2
Assembly note	The quality of a crimp connection is determined by DIN EN 60352-2.

Product properties

Product type	Thermal contact
Series	HC-M-06; HC-M-HV; HC-M-08; HC-A; HC-BB; HC-B; HC-HV
Contact material type	turned

Electrical properties

Rated current	16 A
---------------	------

Connection data

Connection technology

Contact connection type	Pin
Connection method	Crimp connection

Conductor connection

Stripping length	7.5 mm (9.5 mm at HC-M-HV...)
------------------	-------------------------------

Dimensions

Dimensional drawing	
Width [w]	4.5 mm
Height [h]	4.5 mm
Depth	25 mm
Diameter (Contact diameter)	2.5 mm

Material specifications

Material Contact	Iron
Material Contact surface	hard gold-plated

Mechanical properties

Mechanical data

Insertion/withdrawal cycles	≥ 500
-----------------------------	-------

Environmental and real-life conditions

CK2,5-ED-0,5ST FE - Crimp contact

1585760

<https://www.phoenixcontact.com/us/products/1585760>



Ambient conditions

Ambient temperature (operation)

-40 °C ... 125 °C

CK2,5-ED-0,5ST FE - Crimp contact



1585760

<https://www.phoenixcontact.com/us/products/1585760>

Drawings

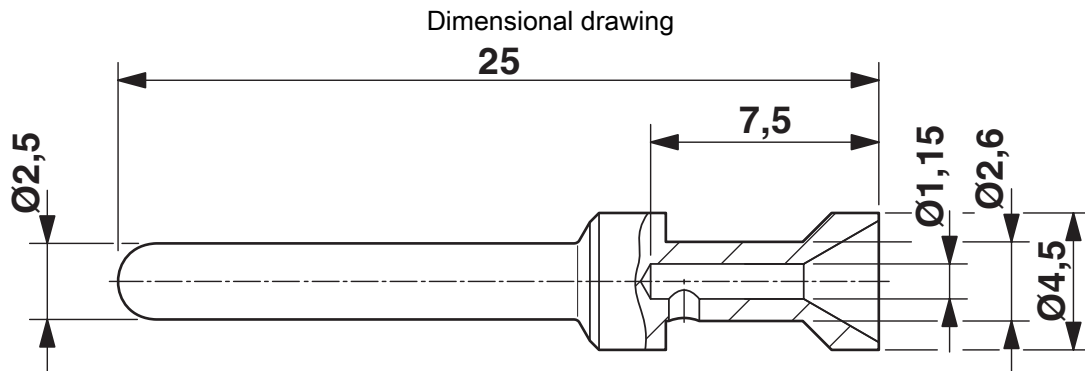

Dimensional drawing

CK2,5-ED-0,5ST FE - Crimp contact



1585760

<https://www.phoenixcontact.com/us/products/1585760>

Classifications

ECLASS

ECLASS-13.0	27440204
ECLASS-15.0	27440204

ETIM

ETIM 10.0	EC000796
-----------	----------

UNSPSC

UNSPSC 21.0	39121500
-------------	----------

CK2,5-ED-0,5ST FE - Crimp contact



1585760

<https://www.phoenixcontact.com/us/products/1585760>

Environmental product compliance

EU RoHS

Fulfills EU RoHS substance requirements	Yes, No exemptions
---	--------------------

China RoHS

Environment friendly use period (EFUP)	EFUP-E
	No hazardous substances above the limits

EU REACH SVHC

REACH candidate substance (CAS No.)	No substance above 0.1 wt%
-------------------------------------	----------------------------

Phoenix Contact 2026 © - all rights reserved
<https://www.phoenixcontact.com>

Phoenix Contact USA
586 Fulling Mill Road
Middletown, PA 17057, United States
(+717) 944-1300
info@phoenixcon.com