

QPDW3PE1,5 6-10 M25 0,1 BKKTH - Panel feed-through



1582475

<https://www.phoenixcontact.com/us/products/1582475>

Please be informed that the data shown in this PDF document is generated from our online catalog. Please find the complete data in the user documentation. Our general terms of use for downloads are valid.



QUICKON panel feed-through, 3-pos. +PE, 1.0 mm² ... 2.5 mm² / 630 V / 20 A, with QUICKON nut for cable diameters of 6 mm 10 mm, with 4 welded-on 1.5 mm² cable wires, 0.1 m long, with ring cable lugs at the end

Your advantages

- Innovative and time saving - QUICKON fast connection for time saving of up to 80 % for on-site connection
- Robust throughout: housing with IP68/IP69K and IK07 protection for a wide range of applications
- Safer connection with mechanical coding to protect against mismatching, and touch-proof protection in accordance with DIN EN 0105
- Efficient - by using panel feed-throughs, devices no longer need to be opened in order to connect cables

Commercial data

Item number	1582475
Packing unit	1 pc
Note	Made to order (non-returnable)
Sales key	BF50
Product key	AF6ABB
GTIN	4046356463362
Weight per piece (including packing)	53.21 g
Weight per piece (excluding packing)	48.1 g
Customs tariff number	85444290
Country of origin	DE

QPDW3PE1,5 6-10 M25 0,1 BKKTH - Panel feed-through

1582475

<https://www.phoenixcontact.com/us/products/1582475>

Technical data

Product properties

Product type	Panel feed-through
Product family	QPD
Type	QPD 4x2,5
Number of positions	4
Connection profile	3+PE
Position marking	1, 2, 3, PE
Number of connections	10
Number of connections per position	1
Coding	coded

Insulation characteristics

Overvoltage category	III
Degree of pollution	3

Connection data

Connection technology

Connection method On the device side	Single wires
Frequency of connections between conductors of the same cross section	max. 10

Conductor connection

Conductor cross-section flexibel	1 mm ² ... 2.5 mm ²
Conductor cross-section solid	1 mm ² ... 2.5 mm ²
Connection cross section AWG	16 ... 14
Tightening torque Union nut	8 Nm
Tightening torque Locking nut	5 Nm
Wrench size Union nut	22 mm
Wrench size Locking nut	27 mm

Dimensions

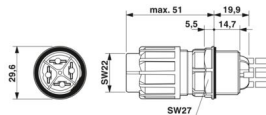
Dimensional drawing	
Width	29.6 mm
Height	29.6 mm
Length	71 mm
Wrench size	27 mm
Wrench size for mounting	27 mm

Electrical properties

QPDW3PE1,5 6-10 M25 0,1 BKKTH - Panel feed-through



1582475

<https://www.phoenixcontact.com/us/products/1582475>

Rated surge voltage (II/2)	8 kV
Rated surge voltage (III/2)	8 kV
Rated surge voltage (III/3)	6 kV
Rated current	20 A
Contact resistance	< 3 mΩ
rated voltage (II/2)	1000 V
rated voltage (III/2)	1000 V
Rated voltage (III/3)	690 V
Nominal voltage U_N	690 V
Nominal current I_N	20 A

Mechanical properties

Mechanical data

Insertion/withdrawal cycles	≥ 50 (QUICKON connections max. 10)
-----------------------------	---

Material specifications

Color	black (RAL 9005)
Material Housing	PA
Material Contact	CuZn
Material Contact surface	silver-plated
Flammability rating according to UL 94	V0
Material wire insulation	PVC/PE/TPE/rubber

Cable/line

Cable length	0.1 m
Structure of individual litz in acc. with VDE 0295 / smallest wire diameter	VDE 0295 class 1 to 6/min. 0.15 mm
External cable diameter	6 mm ... 10 mm
Wire diameter including insulation	2.5 mm ... 3.8 mm
Position marking	1, 2, 3, PE
Material wire insulation	PVC / PE

Mounting

Mounting type	Front mounting M25
---------------	--------------------

Environmental and real-life conditions

Ambient conditions

Degree of protection	IP66
	IP68
	IP69K
Impact strength	IK07
Ambient temperature (operation)	-40 °C ... 100 °C
Temperature when conductor connected	-5 °C ... 50 °C
Ambient temperature (storage/transport)	-40 °C ... 80 °C

QPDW3PE1,5 6-10 M25 0,1 BKKTH - Panel feed-through

1582475

<https://www.phoenixcontact.com/us/products/1582475>

Drawings

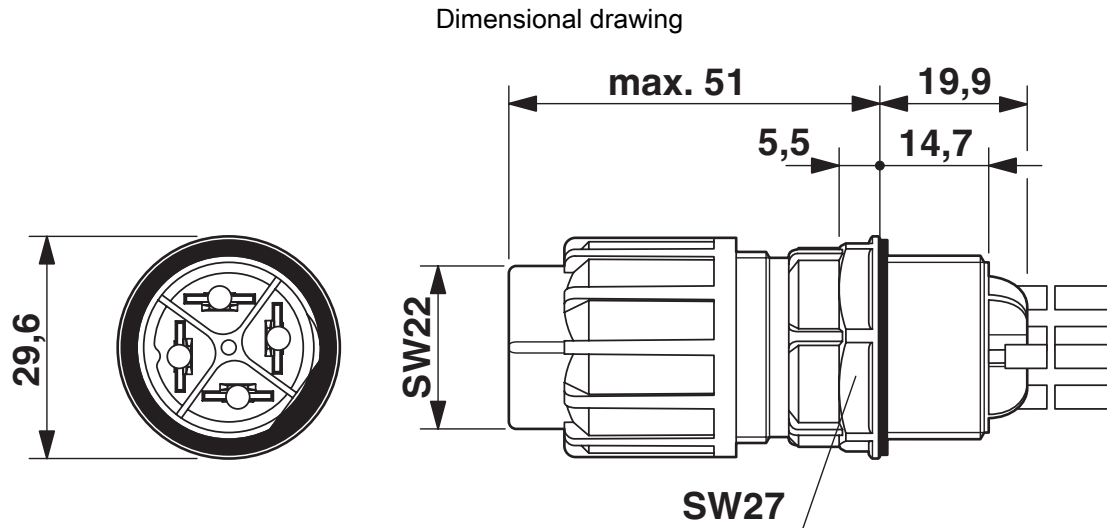

Drawing without line wires

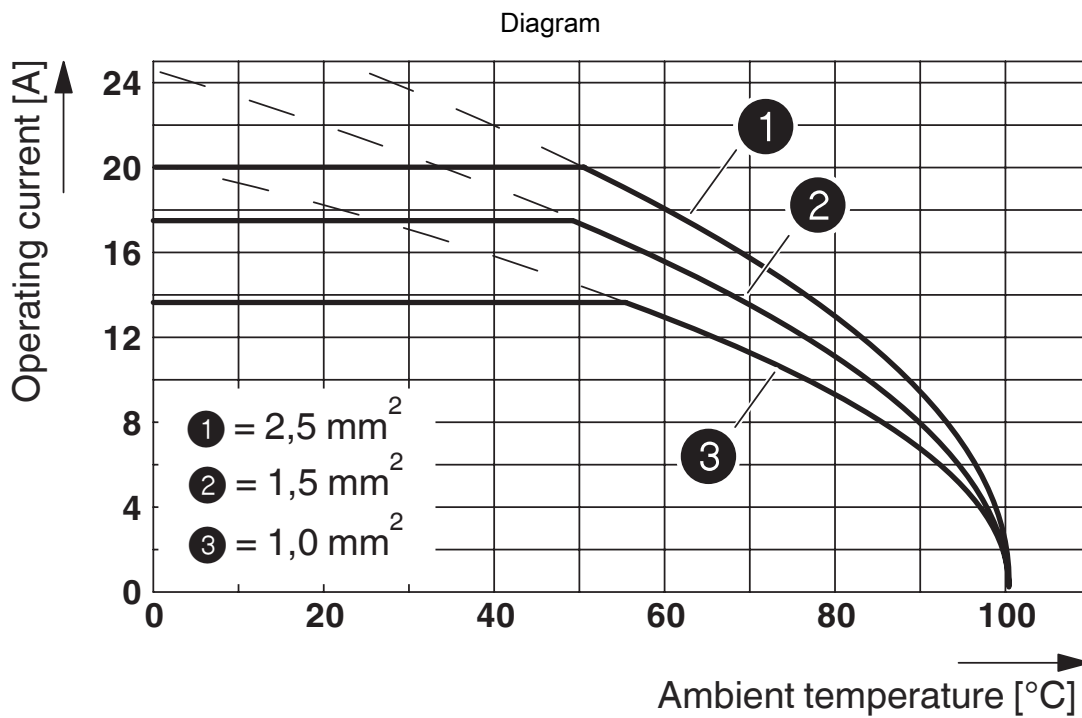

QPDW3PE1,5 6-10 M25 0,1 BKKTH - Panel feed-through



1582475

<https://www.phoenixcontact.com/us/products/1582475>

Classifications

ECLASS

ECLASS-13.0	27440602
ECLASS-15.0	27440602

UNSPSC

UNSPSC 21.0	39121522
-------------	----------

QPDW3PE1,5 6-10 M25 0,1 BKKTH - Panel feed-through



1582475

<https://www.phoenixcontact.com/us/products/1582475>

Environmental product compliance

China RoHS

Environment friendly use period (EFUP)	EFUP-50
	An article-related China RoHS declaration table can be found in the download area for the respective article under "Manufacturer declaration". For all articles with EFUP-E, no China RoHS declaration table issued and required.

EU REACH SVHC

REACH candidate substance (CAS No.)	No substance above 0.1 wt%
-------------------------------------	----------------------------

Phoenix Contact 2026 © - all rights reserved
<https://www.phoenixcontact.com>

Phoenix Contact USA
586 Fulling Mill Road
Middletown, PA 17057, United States
(+717) 944-1300
info@phoenixcon.com