

# SAC-M12-EXCLIP-F - Locking clip

1558991

<https://www.phoenixcontact.com/us/products/1558991>

Please be informed that the data shown in this PDF document is generated from our online catalog. Please find the complete data in the user documentation. Our general terms of use for downloads are valid.



Locking clip for the socket side of sensor/actuator cables with M12 connector and M12 connectors for assembly, for knurl diameter: 15 mm or for Allen key with a wrench size of 14 mm, prevents the disconnection of plug-in connections without tools

## Commercial data

Item number	1558991
Packing unit	10 pc
Minimum order quantity	10 pc
Sales key	BF46
Product key	AF1ZVX
GTIN	4046356299169
Weight per piece (including packing)	3.14 g
Weight per piece (excluding packing)	2.57 g
Customs tariff number	39269097
Country of origin	CN

# SAC-M12-EXCLIP-F - Locking clip



1558991

<https://www.phoenixcontact.com/us/products/1558991>

## Technical data

### Product properties

Product type	Safety locking
--------------	----------------

### Material specifications

Flammability rating according to UL 94	HB
Material for screw connection	TPE-U

### Environmental and real-life conditions

#### Ambient conditions

Ambient temperature (operation) (male connector/female connector)	-40 °C ... 90 °C (Locking clip)
	-40 °C ... 65 °C (for installation)
Ambient temperature (storage/transport)	-40 °C ... 105 °C

# SAC-M12-EXCLIP-F - Locking clip

1558991

<https://www.phoenixcontact.com/us/products/1558991>

## Drawings

Dimensional drawing

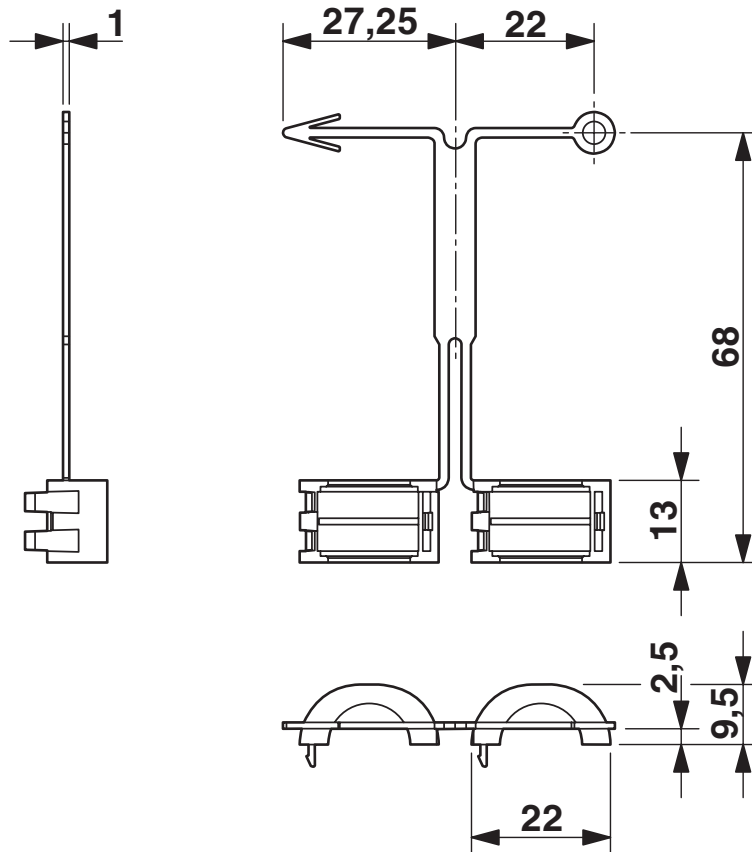

Dimensional drawing

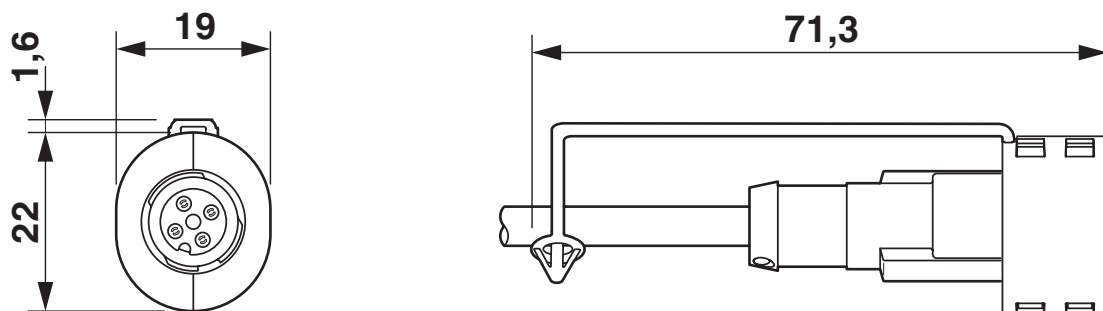

Locking clip mounted on straight M12 connector (not supplied as standard)

# SAC-M12-EXCLIP-F - Locking clip

1558991

<https://www.phoenixcontact.com/us/products/1558991>

Dimensional drawing

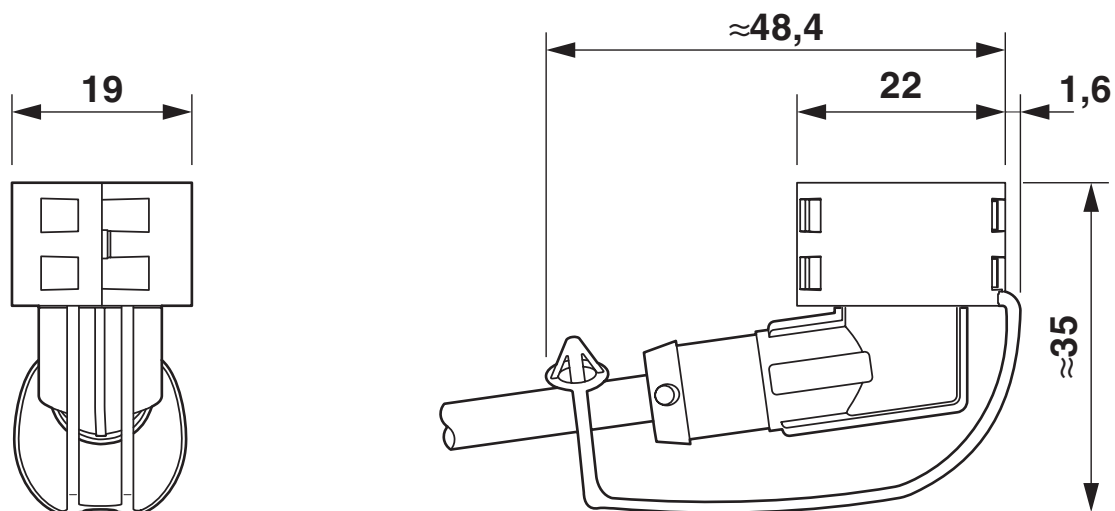

Locking clip mounted on angled M12 connector (not supplied as standard)

# SAC-M12-EXCLIP-F - Locking clip



1558991

<https://www.phoenixcontact.com/us/products/1558991>

## Classifications

### ECLASS

ECLASS-15.0	27440192
ECLASS-13.0	27440192

### ETIM

ETIM 10.0	EC002943
-----------	----------

### UNSPSC

UNSPSC 21.0	39121400
-------------	----------

# SAC-M12-EXCLIP-F - Locking clip



1558991

<https://www.phoenixcontact.com/us/products/1558991>

## Environmental product compliance

### EU RoHS

Fulfills EU RoHS substance requirements	Yes, No exemptions
-----------------------------------------	--------------------

### China RoHS

Environment friendly use period (EFUP)	EFUP-E
	No hazardous substances above the limits

### EU REACH SVHC

REACH candidate substance (CAS No.)	No substance above 0.1 wt%
-------------------------------------	----------------------------

### EF3.1 Climate Change

CO2e kg	0.08 kg CO2e
---------	--------------

Phoenix Contact 2026 © - all rights reserved  
<https://www.phoenixcontact.com>

Phoenix Contact USA  
586 Fulling Mill Road  
Middletown, PA 17057, United States  
(+717) 944-1300  
[info@phoenixcon.com](mailto:info@phoenixcon.com)