

CHARX T1HBI12-1AC80DC200-7,0M1 - Vehicle charging inlet



1507250

<https://www.phoenixcontact.com/us/products/1507250>

Please be informed that the data shown in this PDF document is generated from our online catalog. Please find the complete data in the user documentation. Our general terms of use for downloads are valid.



The figure shows a version of the product

CHARX connect universal, AC/DC CCS Typ 1, Vehicle charging inlet, 200 A permanent, 1000 V DC, 80 A , 250 V AC, Single-core wires connected at one end, locking actuator: 12 V, 4-pos., Front and rear mounting, M6, housing: black, for charging with alternating current (AC) and with direct current (DC), IEC 62196-2, IEC 62196-3, A protective cap is supplied as standard for the DC and AC contacts.

Product description

Vehicle charging inlet for charging with alternating current (AC) and direct current (DC), compatible with type 1 AC and CCS vehicle charging connectors (EVSE), for installation in electric vehicles (EV).

Your advantages

- Complete product range
- Uniform, space-saving dimensions for the installation space and the screw connection points of all Phoenix Contact vehicle charging inlets
- Developed and produced in accordance with the IATF 16949 automotive standard and ISO 9001
- Integrated interlock during charging
- Manual emergency release of the locking actuator
- Protected and sealed against dirt and water with a high degree of protection

Commercial data

Item number	1507250
Packing unit	1 pc
Minimum order quantity	1 pc
Sales key	EM01
Product key	XWCAIB
GTIN	4063151968601
Weight per piece (including packing)	19,063 g
Weight per piece (excluding packing)	18.508 g
Customs tariff number	85444290
Country of origin	PL

CHARX T1HBI12-1AC80DC200-7,0M1 - Vehicle charging inlet



1507250

<https://www.phoenixcontact.com/us/products/1507250>

Technical data

Product properties

Product type	Vehicle charging inlet
Product family	CHARX connect universal
Charging standard	AC/DC CCS Typ 1
Charging mode	Mode 2, 3, 4
Customer variations	On request

Electrical properties

Charging power and current (AC charging, 1-phase)

Type of charging current	AC single-phase
Charging current	80 A AC (1-phase)
Charging power	20 kW

Charging power and current (DC charging)

Type of charging current	DC
Charging current	200 A DC
Charging power	200 kW

Pin assignment (Power contacts)

Note on the connection method	Crimp connection, cannot be disconnected
Number	5 (L1, N, PE, DC+, DC-)
Rated voltage	250 V AC
	1000 V DC
Rated current	80 A AC
	200 A DC

Pin assignment (Signal contacts)

Note on the connection method	Crimp connection, cannot be disconnected
Type of signal transmission	Pulse width modulation with modulated Powerline communication in accordance with ISO/IEC 15118 / DIN SPEC 70121
Number	2 (CP, CS)
Rated voltage	30 V AC
Rated current	2 A
Coding	2.7 k Ω (between PE and CS)
Insulation resistance	> 200 M Ω

Locking actuator

Locking actuator	12 V, 4-pos.
	Top center position
Possible power supply range at the motor	9 V ... 16 V
Maximum voltage for locking detection	12 V
Typical motor current for locking	0.25 A

CHARX T1HBI12-1AC80DC200-7,0M1 - Vehicle charging inlet



1507250

<https://www.phoenixcontact.com/us/products/1507250>

Reverse current of the motor	max. 1.5 A
Max. dwell time with reverse current	1 s
Recommended adaptation time	600 ms
Pause time after entry or exit path	3 s
Service life insertion cycles	> 10000 load cycles
Lock recognition	available
Mechanical emergency release	available
Ambient temperature (operation)	-40 °C ... 80 °C

Temperature sensors (PTC chain)

Sensor type	PTC chain
Standards/regulations	DIN EN 60738-1
Attachment point	Sensor for the AC contacts
Measuring range_resistance	790 Ω ... 1420 Ω
Resistance	max. 1200 Ω ±5 K
Ambient temperature	-40 °C ... 130 °C (Operation)

Temperature sensors (Pt 1000)

Sensor type	Pt 1000
Standards/regulations	DIN EN 60751
Attachment point	2 sensors for the DC contacts

Material specifications

Color (Housing)	black (9005)
Color (Mating face)	black (9005)
Material (Housing)	Plastic
Material (Contact surface)	Silver

Cable/line

Cable type	Single-core wires connected at one end
------------	--

Single-core wires for AC

Cable length	7 m
--------------	-----

Single-core wires for DC

Cable length	7 m
Cable structure	2 x 70 mm ²
Single wire, material	Silicone
Single wire, color	OG
External cable diameter	17.90 mm ±0.3 mm
Cable resistance	≤ 0.259 Ω/km

Single-core wire for PE

Cable length	7 m
Cable structure	1 x 25 mm ²
Single wire, material	Silicone

CHARX T1HBI12-1AC80DC200-7,0M1 - Vehicle charging inlet



1507250

<https://www.phoenixcontact.com/us/products/1507250>

Single wire, color	GN/YE
External cable diameter	8.60 mm ±0.1 mm
Cable resistance	≤ 0.743 Ω/km

Single-core wires for locking actuator

Cable length	1 m
Cable structure	4 x 0.5 mm ²
Single wire, material	PVC
Single wire, color	BU/RD, BU/GN, BU/YE, BU/BN
External cable diameter	1.60 mm ±0.20 mm
Cable resistance	≤ 37.1 Ω/m

Single-core wires for PTC temperature sensors

Cable length	1 m
Cable structure	5 x 0,5 mm ²
Single wire, color	BN/GY BN/YE/GN
External cable diameter	1.60 mm ±0.20 mm
Cable resistance	≤ 37.1 Ω/m

Single-core wires for Pt 1000 temperature sensors

Cable length	0.9 m
Cable structure	3 x 0.5 mm ²
Single wire, material	PVC
Single wire, color	BN GN YE
External cable diameter	1.60 mm ±0.20 mm
Cable resistance	≤ 37.1 Ω/m

Single-core wires for communication

Cable length	1 m
Cable structure	2 x 0.5 mm ²
Single wire, material	PVC
Single wire, color	BK WH
External cable diameter	1.60 mm ±0.20 mm
Cable resistance	≤ 37.1 Ω/m

Mechanical properties

Mechanical data

Insertion/withdrawal cycles	> 10000
Insertion force	< 100 N
Withdrawal force	< 100 N

CHARX T1HBI12-1AC80DC200-7,0M1 - Vehicle charging inlet



1507250

<https://www.phoenixcontact.com/us/products/1507250>

Environmental and real-life conditions

Ambient conditions

Altitude	4000 m (above sea level)
----------	--------------------------

Standards and regulations

Standards

Standards/regulations	IEC 62196-2
	IEC 62196-3
	SAE J1772

Mounting

Mounting type	Front and rear mounting (0 to 90 degree frontal inclination possible)
Mounting hole diameter	6.70 mm (ø)
Fixing screws	M6
Screws included in the scope of delivery	none

CHARX T1HBI12-1AC80DC200-7,0M1 - Vehicle charging inlet



1507250

<https://www.phoenixcontact.com/us/products/1507250>

Drawings

Dimensional drawing



Dimensional drawing

CHARX T1HBI12-1AC80DC200-7,0M1 - Vehicle charging inlet

1507250

<https://www.phoenixcontact.com/us/products/1507250>

Connection diagram



Pin assignment of vehicle charging inlets

Connection diagram



Installation positions

CHARX T1HBI12-1AC80DC200-7,0M1 - Vehicle charging inlet

1507250

<https://www.phoenixcontact.com/us/products/1507250>



Detection for Vehicle Connector



The Combined Charging System (CCS) principle - standard-compliant charging system for electric vehicles, which supports both conventional AC charging and fast DC charging. Both Vehicle Connectors fit into the CCS Vehicle Inlet.

CHARX T1HBI12-1AC80DC200-7,0M1 - Vehicle charging inlet

1507250

<https://www.phoenixcontact.com/us/products/1507250>

Schematic diagram



Operating instructions

CHARX T1HBI12-1AC80DC200-7,0M1 - Vehicle charging inlet



1507250

<https://www.phoenixcontact.com/us/products/1507250>

Schematic diagram



Block diagram of the locking actuator

Schematic diagram

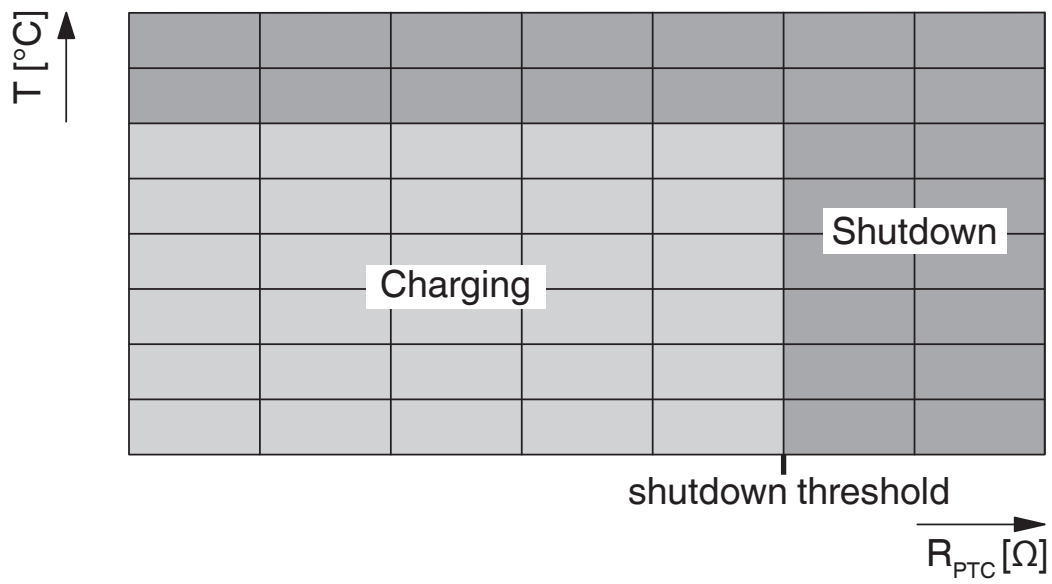

Temperature sensor technology resistance range at AC contacts

CHARX T1HBI12-1AC80DC200-7,0M1 - Vehicle charging inlet



1507250

<https://www.phoenixcontact.com/us/products/1507250>



Locking states of the locking actuator

CHARX T1HBI12-1AC80DC200-7,0M1 - Vehicle charging inlet



1507250

<https://www.phoenixcontact.com/us/products/1507250>

Diagram



Pt 1000 characteristic curve at an ambient temperature of 25°C for temperature measurement at the DC contacts

CHARX T1HBI12-1AC80DC200-7,0M1 - Vehicle charging inlet



1507250

<https://www.phoenixcontact.com/us/products/1507250>

Classifications

ECLASS

ECLASS-13.0	27144706
ECLASS-15.0	27144706

ETIM

ETIM 10.0	EC002898
-----------	----------

CHARX T1HBI12-1AC80DC200-7,0M1 - Vehicle charging inlet



1507250

<https://www.phoenixcontact.com/us/products/1507250>

Environmental product compliance

EU RoHS

Fulfills EU RoHS substance requirements	Yes
Exemption	6(c), 7(c)-I

China RoHS

Environment friendly use period (EFUP)	EFUP-50
	An article-related China RoHS declaration table can be found in the download area for the respective article under "Manufacturer declaration". For all articles with EFUP-E, no China RoHS declaration table issued and required.

EU REACH SVHC

REACH candidate substance (CAS No.)	2-ethylhexyl 10-ethyl-4,4-dioctyl-7-oxo-8-oxa-3,5-dithia-4-stannatetradecanoate (DOTE)(CAS: 15571-58-1)
	Lead(CAS: 7439-92-1)
	Bis(2-(2-methoxyethoxy)ethyl)ether(CAS: 143-24-8)
	6,6'-di-tert-butyl-2,2'-methylenedi-p-cresol(CAS: 119-47-1)
SCIP	c0728d94-1eb9-4ed4-97e1-5fcee48f5249

EF3.1 Climate Change

CO2e kg	118.4 kg CO2e
---------	---------------

Phoenix Contact 2026 © - all rights reserved
<https://www.phoenixcontact.com>

Phoenix Contact USA
586 Fulling Mill Road
Middletown, PA 17057, United States
(+717) 944-1300
info@phoenixcon.com