

# SAC-2P-M12MSB/ 2,0-910 - Bus system cable



1507243

<https://www.phoenixcontact.com/us/products/1507243>

Please be informed that the data shown in this PDF document is generated from our online catalog. Please find the complete data in the user documentation. Our general terms of use for downloads are valid.



Bus system cable, PROFIBUS (12 Mbps), 2-position, PUR halogen-free, red lilac RAL 4001, shielded, Plug straight M12, coding: B, on free cable end, cable length: 2 m

## Commercial data

Item number	1507243
Packing unit	1 pc
Minimum order quantity	1 pc
Sales key	BF04
Product key	AF1CKC
GTIN	4017918900083
Weight per piece (including packing)	142.9 g
Weight per piece (excluding packing)	142.9 g
Customs tariff number	85444290
Country of origin	PL

# SAC-2P-M12MSB/ 2,0-910 - Bus system cable



1507243

<https://www.phoenixcontact.com/us/products/1507243>

## Technical data

### Product properties

Product type	Data cable preassembled
Application	Standard
Number of positions	2
No. of cable outlets	1
Shielded	yes
Coding	B

### Insulation characteristics

Overvoltage category	II
Degree of pollution	3

### Interfaces

Bus system	PROFIBUS
Signal type/category	PROFIBUS, 12 Mbps (max. 100 m)

### Signaling

Status display	no
Status display present	no

### Electrical properties

Insulation resistance	$\geq 100 \text{ M}\Omega$
Nominal voltage $U_N$	48 V AC
	60 V DC
Nominal current $I_N$	4 A
Transmission medium	Copper
Transmission speed	12 Mbps (max. 100 m)

### Mechanical properties

#### Mechanical data

Insertion/withdrawal cycles	$\geq 100$
-----------------------------	------------

### Material specifications

Material of grip body	TPU, hardly inflammable, self-extinguishing
Contact material	CuSn
Contact surface material	Ni/Au
Contact carrier material	PA 6.6
Material for screw connection	Zinc die-cast, nickel-plated

### Connection data

#### Connection assignment

# SAC-2P-M12MSB/ 2,0-910 - Bus system cable

1507243

<https://www.phoenixcontact.com/us/products/1507243>

Contact   Color (signal designation)   Contact (optional)	2 (Plug)   GN (A cable)
	4 (Plug)   RD (B cable)

## Connector

### Connection 1

Type	Plug straight M12
Number of positions	2
Coding type	B (inverse)

### Connection 2

Type	free cable end
------	----------------

## Cable/line

Cable length	2 m
--------------	-----

### PROFIBUS [910]

Dimensional drawing	
UL AWM Style	21198 (80°C/300 V)
Number of positions	2
Shielded	yes
Cable type	PROFIBUS [910]
Conductor structure	1x2xAWG24/19
AWG signal line	24
Conductor cross-section	2x 0.25 mm <sup>2</sup> (Signal line)
Wire diameter incl. insulation	2.55 mm ±0.05 mm
External cable diameter	7.70 mm ±0.02 mm
Outer sheath, material	PUR
External sheath, color	red lilac RAL 4001
Conductor material	Tin-plated Cu litz wires
Single wire, color	red, green
Overall twist	2 cores with 2 fillers to the core
Optical shield covering	80 %
Insulation resistance	≥ 5 GΩ*km
Wave impedance	150 Ω ±10 % (3 MHz ... 20 MHz)
Nominal voltage, cable	≤ 125 V
Test voltage Core/Core	2000 V (50 Hz, 1 min.)
Test voltage Core/Shield	2000.00 V (50 Hz, 1 min.)

# SAC-2P-M12MSB/ 2,0-910 - Bus system cable



1507243

<https://www.phoenixcontact.com/us/products/1507243>

Minimum bending radius, fixed installation	4 x D
Minimum bending radius, flexible installation	8 x D
Dynamic load capacity (bending)	Max. bending cycles: 4000000, Bending radius: 65 mm, Bending radius: 15 x D, Traversing path: 4.5 m, Traversing rate: 3 m/s, Acceleration: 3 m/s <sup>2</sup>
Shield attenuation	≤ 4.9 dB (at 16 MHz)
	≤ 4.9 dB (at 4 MHz)
	≤ 0.5 dB (at 38.4 kHz)
	≤ 0.3 dB (at 9.6 kHz)
Halogen-free	in accordance with DIN VDE 0472 part 815
	according to IEC 60754-1
Flame resistance	UL 1581, Section 1060 and UL 2556, Section 9.3 (FT1)
	UL 1581, Section 1100 and UL 2556, Section 9.1 (HFT/FT2)
	IEC 60332-1-2
Resistance to oil	in accordance with DIN EN 60811-404
Ambient temperature (operation)	-40 °C ... 80 °C (cable, fixed installation)
	-30 °C ... 70 °C (Cable, flexible installation)
	-20 °C ... 60 °C (for installation)
	-20 °C ... 60 °C (cable, drag chain applications)

## Environmental and real-life conditions

### Ambient conditions

Degree of protection	IP65
	IP67
Ambient temperature (operation) (male connector/female connector)	-25 °C ... 90 °C (Plug / socket)

# SAC-2P-M12MSB/ 2,0-910 - Bus system cable



1507243

<https://www.phoenixcontact.com/us/products/1507243>

## Drawings

Dimensional drawing

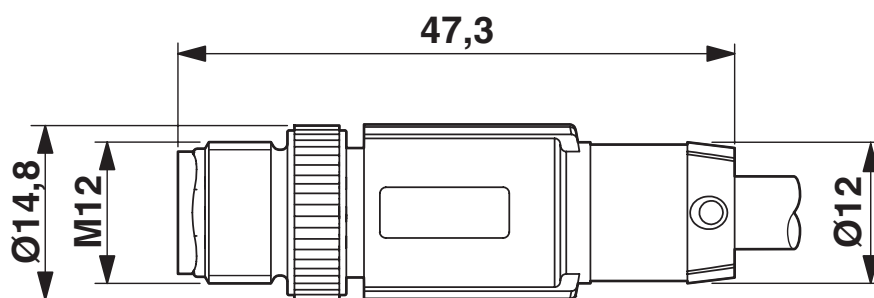

Plug, M12 x 1, straight, shielded

Schematic diagram



Pin assignment M12 male connector, 5-pos., B-coded, male side

Circuit diagram



Contact assignment of the M12 plug

# SAC-2P-M12MSB/ 2,0-910 - Bus system cable



1507243

<https://www.phoenixcontact.com/us/products/1507243>

## Approvals

To download certificates, visit the product detail page: <https://www.phoenixcontact.com/us/products/1507243>

 <b>UL Listed</b> Approval ID: FILE E 221474				
	Nominal voltage $U_N$	Nominal current $I_N$	Cross section AWG	Cross section $\text{mm}^2$
keine				
	300 V	4 A	-	-

 <b>cUL Listed</b> Approval ID: FILE E 221474				
	Nominal voltage $U_N$	Nominal current $I_N$	Cross section AWG	Cross section $\text{mm}^2$
keine				
	300 V	4 A	-	-

 <b>EAC-RoHS</b> Approval ID: RU D-DE.HB35.B.00387	
--	--

# SAC-2P-M12MSB/ 2,0-910 - Bus system cable



1507243

<https://www.phoenixcontact.com/us/products/1507243>

## Classifications

### ECLASS

ECLASS-13.0	27060307
ECLASS-15.0	27060307

### UNSPSC

UNSPSC 21.0	26121600
-------------	----------

# SAC-2P-M12MSB/ 2,0-910 - Bus system cable



1507243

<https://www.phoenixcontact.com/us/products/1507243>

## Environmental product compliance

### EU RoHS

Fulfills EU RoHS substance requirements	Yes, No exemptions
---	--------------------

### China RoHS

Environment friendly use period (EFUP)	EFUP-E
	No hazardous substances above the limits

### EU REACH SVHC

REACH candidate substance (CAS No.)	No substance above 0.1 wt%
-------------------------------------	----------------------------

### EF3.1 Climate Change

CO2e kg	1.466 kg CO2e
---------	---------------

Phoenix Contact 2026 © - all rights reserved  
<https://www.phoenixcontact.com>

Phoenix Contact USA  
586 Fulling Mill Road  
Middletown, PA 17057, United States  
(+717) 944-1300  
[info@phoenixcon.com](mailto:info@phoenixcon.com)