

# UCS HH-HS 125-87 9005 - Housing half-shell



1494977

<https://www.phoenixcontact.com/us/products/1494977>

Please be informed that the data shown in this PDF document is generated from our online catalog. Please find the complete data in the user documentation. Our general terms of use for downloads are valid.



Housing half-shell for creating a UCS housing with the dimensions 125 mm x 87 mm with heatsink. Half shell is prepared to accommodate a UCS HS-HH 125-87 AL heatsink, material: polycarbonate, color: black, similar to RAL 9005

## Your advantages

- High degree of application flexibility, thanks to the modular housing design
- Flexible PCB attachment, adapts to virtually all form factors
- Practical customization options
- Reduced logistics outlay, thanks to components which are compatible with one another

## Commercial data

Item number	1494977
Packing unit	20 pc
Minimum order quantity	20 pc
Note	Made to order (non-returnable)
Sales key	AC03
Product key	ACFCAA
GTIN	4063151943677
Weight per piece (including packing)	46.2 g
Weight per piece (excluding packing)	30.78 g
Customs tariff number	84879090
Country of origin	DE

# UCS HH-HS 125-87 9005 - Housing half-shell

1494977

<https://www.phoenixcontact.com/us/products/1494977>

## Technical data

### Notes

Assembly note	Please observe the application note in the download area.
---------------	---

### Product properties

Product type	Housing half shells
Housing type	Universal housings
Housing series	UCS
Product family	UCS 125-87
Ventilation openings present	no

### Dimensions

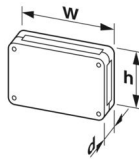
Dimensional drawing	
Width	125 mm
Height	87 mm
Depth	21.75 mm

### PCB design

PCB thickness	0.8 mm ... 3 mm
---------------	-----------------

### Material specifications

Color (Housing)	black (RAL 9005)
Material Housing	PC
Flammability rating according to UL 94	V0
CTI according to IEC 60112	225
Insulating material	PC

### Environmental and real-life conditions

#### Vibration test

Specification	IEC 60068-2-6:2007-12
Frequency	10 - 150 - 10 Hz
Sweep speed	1 octave/min
Amplitude	0.15 mm (10 Hz ... 58.1 Hz)
Acceleration	2g (58.1 Hz ... 150 Hz)
Test duration per axis	2.5 h
Test directions	X-, Y- and Z-axis

#### Glow-wire test

# UCS HH-HS 125-87 9005 - Housing half-shell



1494977

<https://www.phoenixcontact.com/us/products/1494977>

Specification	IEC 60695-2-11:2014-02
Temperature	850 °C
Time of exposure	30 s

## Thermal stability / ball thrust test

Specification	IEC 60695-10-2:2014-02
Temperature	125 °C
Test duration	1 h
Force	20 N

## Mechanical strength / tumbling barrel

Specification	IEC 60068-2-31:2008-05
Height of fall	50 cm
Frequency	50

## Shocks

Specification	IEC 60068-2-27:2008-02
Pulse shape	Half-sine
Acceleration	15g
Shock duration	11 ms
Number of shocks per direction	3
Test directions	X-, Y- and Z-axis (pos. and neg.)

## Test for substances that would hinder coating with paint or varnish

Specification	VW PV 3.10.7:2005-02
Result	Test passed

## Degree of protection (IP code)

Specification	IEC 60529:1989-11 + AMD 1:1999-11 + AMD 2:2013-08
Result, degree of protection, IP code	IP40

## Ambient conditions

Max. IP code to attain	IP40
Ambient temperature (operation)	-40 °C ... 105 °C (depending on power dissipation)
Ambient temperature (storage/transport)	-40 °C ... 70 °C
Ambient temperature (assembly)	-5 °C ... 100 °C
Relative humidity (storage/transport)	95 %

## PCB data

Type of PCB mount	Bolt mounting
Thickness of the PCB	0.8 mm ... 3 mm

## Mounting

Mounting type	Screw mounting
Mounting position	any
Tightening torque / speed	Screw connection between housing halves: 1.2 - 1.4 Nm / 500 - 1000 rpm

# UCS HH-HS 125-87 9005 - Housing half-shell



1494977

<https://www.phoenixcontact.com/us/products/1494977>

	Mounting of PCB on corner feeder: 0.4 - 0.5 Nm / 500 - 1000 rpm
Tightening torque	1.2 Nm ... 1.4 Nm
Tightening torque	0.4 Nm ... 0.5 Nm

## Packaging specifications

Type of packaging	Box packaging
-------------------	---------------

# UCS HH-HS 125-87 9005 - Housing half-shell

1494977

<https://www.phoenixcontact.com/us/products/1494977>



## Drawings

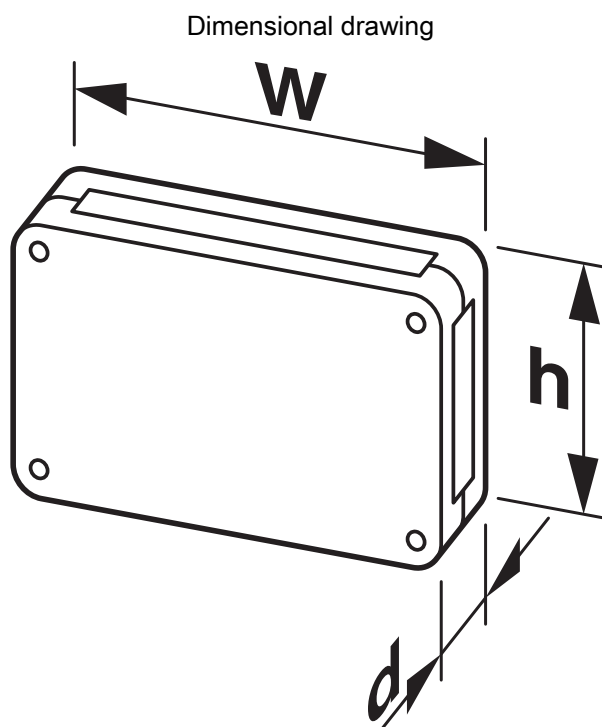

Schematic representation – for additional information, see product range drawing in the Download Center

# UCS HH-HS 125-87 9005 - Housing half-shell



1494977

<https://www.phoenixcontact.com/us/products/1494977>

## Classifications

### ECLASS

ECLASS-13.0	27190603
ECLASS-15.0	27190603

### ETIM

ETIM 10.0	EC002779
-----------	----------

# UCS HH-HS 125-87 9005 - Housing half-shell



1494977

<https://www.phoenixcontact.com/us/products/1494977>

## Environmental product compliance

### EU RoHS

Fulfills EU RoHS substance requirements	Yes, No exemptions
---	--------------------

### China RoHS

Environment friendly use period (EFUP)	EFUP-E
	No hazardous substances above the limits

### EU REACH SVHC

REACH candidate substance (CAS No.)	Perfluorobutane sulfonic acid (PFBS) and its salts(CAS: n/a)
SCIP	d6a9ffd9-5cad-4452-849d-1e0ec38e6ad9

Phoenix Contact 2026 © - all rights reserved

<https://www.phoenixcontact.com>

Phoenix Contact USA  
586 Fulling Mill Road  
Middletown, PA 17057, United States  
(+717) 944-1300  
[info@phoenixcon.com](mailto:info@phoenixcon.com)