

# NBC-P12MSD/ 5,0-93E/P12MSD - Network cable



1476051

<https://www.phoenixcontact.com/us/products/1476051>

Please be informed that the data shown in this PDF document is generated from our online catalog. Please find the complete data in the user documentation. Our general terms of use for downloads are valid.



Network cable, Ethernet CAT5 (100 Mbps), 4-position, PUR halogen-free, water blue RAL 5021, shielded (Advanced Shielding Technology), Plug straight M12 Push Pull, coding: D / IP67, on Plug straight M12 Push Pull, coding: D / IP67, cable length: 5 m

## Commercial data

Item number	1476051
Packing unit	1 pc
Minimum order quantity	1 pc
Sales key	BF04
Product key	AF1CJJ
GTIN	4063151889081
Weight per piece (including packing)	247 g
Weight per piece (excluding packing)	22.22 g
Customs tariff number	85444290
Country of origin	PL

1476051

<https://www.phoenixcontact.com/us/products/1476051>

## Technical data

### Product properties

Product type	Data cable preassembled
Application	Standard
Sensor type	Ethernet
Number of positions	4
Shielded	yes

### Interfaces

Signal type/category	Ethernet CAT5 (IEC 11801), 100 Mbps
----------------------	-------------------------------------

### Electrical properties

Nominal voltage $U_N$	48 V AC
	60 V DC
Nominal current $I_N$	4 A
Transmission medium	Copper
Transmission speed	100 Mbps

### Connector

#### Connection 1

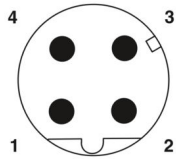
Dimensional drawing	 <p>Pin assignment M12 male connector, 4-pos., D-coded, male side</p>
Type	M12 Plug, straight, 4-position, shielded (Advanced Shielding Technology), Push Pull, Keying: D
Number of positions	4
Shielded	yes
Shielding	Advanced Shielding Technology
Signal type/category	Ethernet CAT5 (IEC 11801), 100 Mbps
Insertion/withdrawal cycles	$\geq 100$
Insulation resistance	$\geq 100 \text{ M}\Omega$
Overvoltage category	II
Degree of pollution	3
Material Contact	CuSn
Material Contact surface	Ni/Au
Material Contact carrier	PK
Material Grip body	TPU, hardly inflammable, self-extinguishing
Material Seal	FKM

# NBC-P12MSD/ 5,0-93E/P12MSD - Network cable



1476051

<https://www.phoenixcontact.com/us/products/1476051>

Flammability rating according to UL 94	V0
Degree of protection	IP65
	IP67
Ambient temperature (operation)	-25 °C ... 85 °C
Standard designation	M12 connector
Standards/regulations	IEC 61076-2-010

## Connection 2

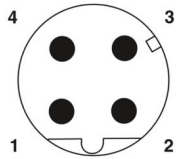
Dimensional drawing	 <p>Pin assignment M12 male connector, 4-pos., D-coded, male side</p>
Type	M12 Plug, straight, 4-position, shielded (Advanced Shielding Technology), Push Pull, Keying: D
Number of positions	4
Shielded	yes
Shielding	Advanced Shielding Technology
Signal type/category	Ethernet CAT5 (IEC 11801), 100 Mbps
Insertion/withdrawal cycles	≥ 100
Insulation resistance	≥ 100 MΩ
Overvoltage category	II
Degree of pollution	3
Material Contact	CuSn
Material Contact surface	Ni/Au
Material Contact carrier	PK
Material Grip body	TPU, hardly inflammable, self-extinguishing
Material Seal	FKM
Flammability rating according to UL 94	V0
Degree of protection	IP65
	IP67
Ambient temperature (operation)	-25 °C ... 85 °C
Standard designation	M12 connector
Standards/regulations	IEC 61076-2-010

## Cable/line

Cable length	5 m
--------------	-----

Ethernet flexible CAT5, 2-pair [93E]

# NBC-P12MSD/ 5,0-93E/P12MSD - Network cable



1476051

<https://www.phoenixcontact.com/us/products/1476051>

Dimensional drawing	
UL AWM Style	21238 (80 °C / 600 V)
Number of positions	4
Shielded	yes
Cable type	Ethernet flexible CAT5, 2-pair [93E]
Conductor structure	2x2xAWG26/7, SF/UTP
AWG signal line	26
Conductor cross-section	2x 2x 0.14 mm <sup>2</sup>
Wire diameter incl. insulation	0.95 mm ±0.05 mm
External cable diameter	6.40 mm ±0.2 mm
Outer sheath, material	PUR
External sheath, color	water blue RAL 5021
Conductor material	Bare Cu litz wires
Material wire insulation	Foamed PE
Single wire, color	white/orange-orange, white/green-green
Twisted pairs	2 cores to the pair
Overall twist	Two pairs with two fillers to the core
Optical shield covering	70 %
Insulation resistance	≥ 5 GΩ*km
Loop resistance	≤ 280.00 Ω/km
Wave impedance	100 Ω ±5 Ω (at 100 MHz)
Nominal voltage, cable	≤ 100 V
Test voltage Core/Core	2000 V (50 Hz, 1 min.)
Test voltage Core/Shield	2000.00 V (50 Hz, 1 min.)
Minimum bending radius, fixed installation	4 x D
Minimum bending radius, flexible installation	8 x D
Smallest bending radius, fixed installation	26 mm
Smallest bending radius, movable installation	51 mm
Halogen-free	according to IEC 60754-1
Flame resistance	according to IEC 60332-1-2 in accordance with UN ECE-R 118.03 UL 1581, Section 1060 and UL 2556, Section 9.3 (FT1) UL 1581, Section 1100 and UL 2556, Section 9.1 (HFT/FT2)
Resistance to oil	in accordance with IEC 60811-404
Ambient temperature (operation)	-40 °C ... 80 °C (cable, fixed installation) -30 °C ... 70 °C (Cable, flexible installation)

Drawings

Dimensional drawing

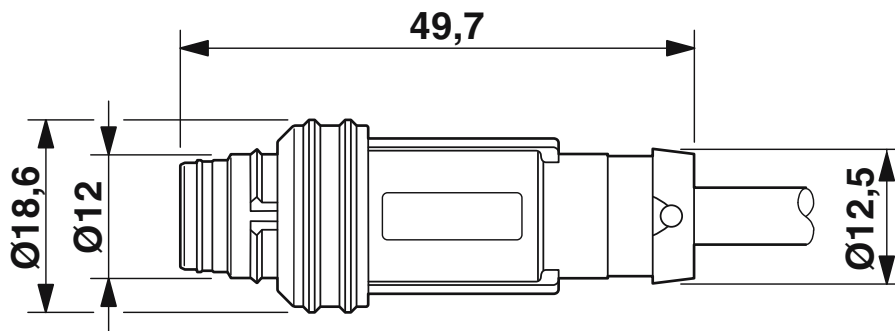

M12 push-pull male connector, straight

Dimensional drawing

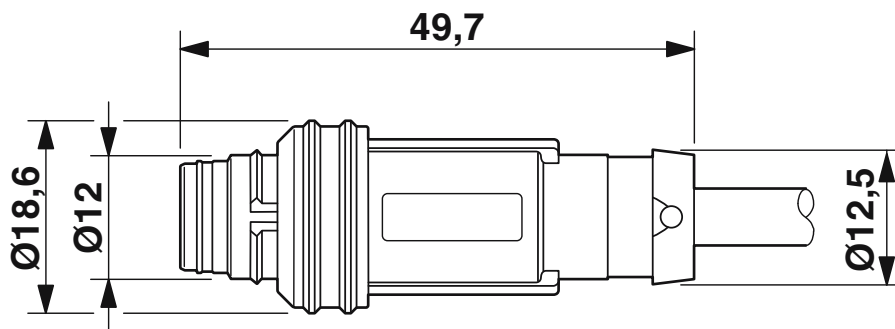

M12 push-pull male connector, straight

1476051

<https://www.phoenixcontact.com/us/products/1476051>

Schematic diagram

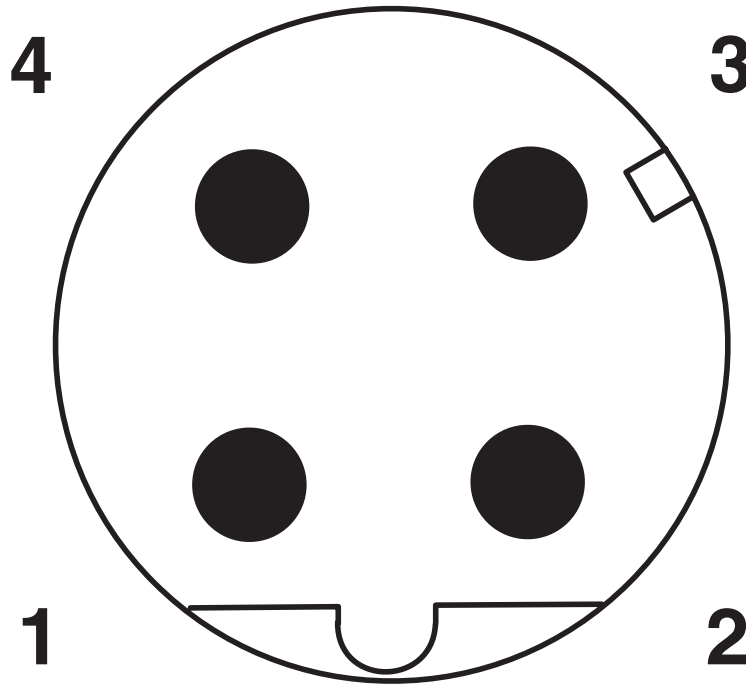

Pin assignment M12 male connector, 4-pos., D-coded, male side

Circuit diagram

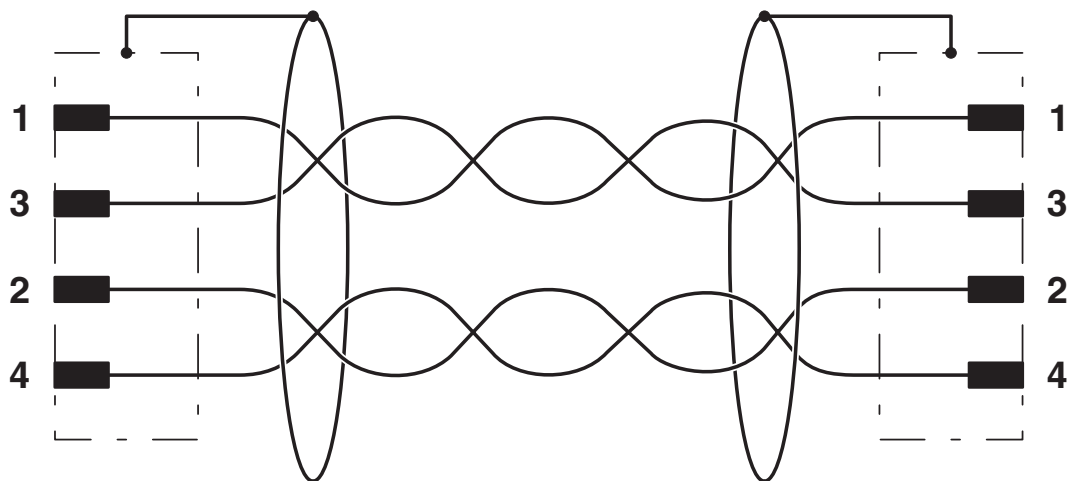

Contact assignment of the M12 plugs

# NBC-P12MSD/ 5,0-93E/P12MSD - Network cable



1476051

<https://www.phoenixcontact.com/us/products/1476051>

## Approvals

To download certificates, visit the product detail page: <https://www.phoenixcontact.com/us/products/1476051>

 <b>cULus Listed</b> Approval ID: E335024				
	Nominal voltage $U_N$	Nominal current $I_N$	Cross section AWG	Cross section $\text{mm}^2$
keine				
	30 V	4 A	-	-

1476051

<https://www.phoenixcontact.com/us/products/1476051>

## Classifications

### ECLASS

ECLASS-13.0	27060307
ECLASS-15.0	27060307

### ETIM

ETIM 10.0	EC001855
-----------	----------

### UNSPSC

UNSPSC 21.0	26121600
-------------	----------



1476051

<https://www.phoenixcontact.com/us/products/1476051>

## Environmental product compliance

### EU RoHS

Fulfills EU RoHS substance requirements	Yes, No exemptions
---	--------------------

### China RoHS

Environment friendly use period (EFUP)	EFUP-E
	No hazardous substances above the limits

### EU REACH SVHC

REACH candidate substance (CAS No.)	No substance above 0.1 wt%
-------------------------------------	----------------------------

### EF3.1 Climate Change

CO2e kg	1.693 kg CO2e
---------	---------------

Phoenix Contact 2026 © - all rights reserved  
<https://www.phoenixcontact.com>

Phoenix Contact USA  
586 Fulling Mill Road  
Middletown, PA 17057, United States  
(+717) 944-1300  
[info@phoenixcon.com](mailto:info@phoenixcon.com)