

HC-B 48-SML-100/O2M32 - Housing



1460228

<https://www.phoenixcontact.com/us/products/1460228>

Please be informed that the data shown in this PDF document is generated from our online catalog. Please find the complete data in the user documentation. Our general terms of use for downloads are valid.

Box mounting base, with single locking latch, height: 100 mm, without screw connection, 2 x M32



Commercial data

Item number	1460228
Packing unit	1 pc
Minimum order quantity	1 pc
Product key	AF7AAC
GTIN	4046356696685
Weight per piece (including packing)	22.22 g
Weight per piece (excluding packing)	22.22 g
Country of origin	DE

HC-B 48-SML-100/O2M32 - Housing

1460228

<https://www.phoenixcontact.com/us/products/1460228>

Technical data

Notes

General	For contact inserts HC-B48, DD216, M
---------	--------------------------------------

Product properties

Product type	Housing with locking latch
Housing type	Surface mounting housing
Type	B48
No. of cable outlets	2
Type of the screw connection	2x M32
Cable outlet	lateral
Pg screw connection	none

Dimensions

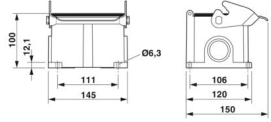
Dimensional drawing	
Width	120 mm
Height	100 mm
Length	145 mm

Material specifications

Seal material	NBR
Housing material	Die-cast aluminum
Housing surface material	Powder-coated, gray
Locking latch material	Steel, galvanized

Mechanical properties

Mechanical data

Type of the screw connection	2x M32
Locking type	Latch

Environmental and real-life conditions

Ambient conditions

Degree of protection	IP65
Ambient temperature (operation)	-40 °C ... 125 °C

HC-B 48-SML-100/O2M32 - Housing



1460228

<https://www.phoenixcontact.com/us/products/1460228>

Drawings

Dimensional drawing

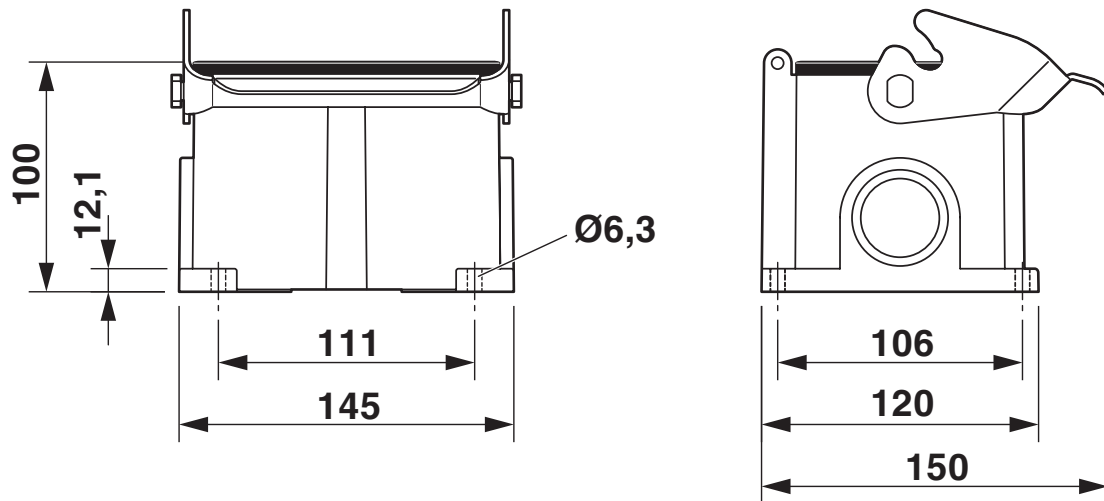

Dimensional drawing

HC-B 48-SML-100/O2M32 - Housing



1460228

<https://www.phoenixcontact.com/us/products/1460228>

Classifications

ECLASS

ECLASS-13.0	27440202
ECLASS-15.0	27440202

HC-B 48-SML-100/O2M32 - Housing



1460228

<https://www.phoenixcontact.com/us/products/1460228>

Environmental product compliance

EU RoHS

Fulfills EU RoHS substance requirements	Yes, No exemptions
---	--------------------

China RoHS

Environment friendly use period (EFUP)	EFUP-E
	No hazardous substances above the limits

EU REACH SVHC

REACH candidate substance (CAS No.)	No substance above 0.1 wt%
-------------------------------------	----------------------------

Phoenix Contact 2026 © - all rights reserved
<https://www.phoenixcontact.com>

Phoenix Contact USA
586 Fulling Mill Road
Middletown, PA 17057, United States
(+717) 944-1300
info@phoenixcon.com