

PTCB E1 24DC/0.1-0.63A SI-R - Electronic circuit breaker



1441496

<https://www.phoenixcontact.com/us/products/1441496>

Please be informed that the data shown in this PDF document is generated from our online catalog. Please find the complete data in the user documentation. Our general terms of use for downloads are valid.

Single-channel, electronic device protection for 12-24 V DC loads. Nominal current adjustable from 0.1-0.63 A. With remote signaling, remote reset, and active current limitation. Can be combined with CLIPLINE terminal blocks. For installation on DIN rails.



Your advantages

- Precise fault localization and fast recovery thanks to status message and local and remote reset options
- Effortless system planning with precise shutdown, low voltage losses, and adjustable current values
- More space in the control cabinet due to integrated potential distribution of positive and negative in 6 mm
- Simple application setup due to bridging option to CLIPLINE complete terminal block system

Commercial data

Item number	1441496
Packing unit	1 pc
Minimum order quantity	1 pc
Sales key	CL10
Product key	CLA135
GTIN	4063151823221
Weight per piece (including packing)	32.25 g
Weight per piece (excluding packing)	25.84 g
Customs tariff number	85363010
Country of origin	DE

PTCB E1 24DC/0.1-0.63A SI-R - Electronic circuit breaker



1441496

<https://www.phoenixcontact.com/us/products/1441496>

Technical data

Notes

General

Note	Connection for signal line tested in accordance with EN 61000-4-4 with 1 kV; if necessary, customer must provide appropriate protective measures
	Repeated hard short circuits can reduce the melting integral of the integrated backup fuse.

Product properties

Product type	Device circuit breakers
Product family	PTCB
Type	DIN rail module, one-piece
Number of positions	1
No. of channels	1

Insulation characteristics

Protection class	III
Pollution degree	2

Electrical properties

General

Operating voltage	10 V DC ... 30 V DC
Rated voltage	12 V DC
	24 V DC
Rated current I_N	15 A (Total current input)
	0.5 A (Rated current output)
Rated current I_N	0.1 / 0.2 / 0.315 / 0.4 / 0.5 / 0.63 A DC (adjustable)
Rated current (pre-adjusted)	0.5 A
Rated surge voltage	0.5 kV
Tripping method	E (electronic)
Feedback resistance	max. 35 V DC
Required backup fuse	Only required if I_{max} of the power supply > the short-circuit switching capacity. Integrated failsafe element.
Short-circuit switching capacity	300 A
Dielectric strength	max. 35 V DC (Load circuit)
Active current limitation	$\leq 1,2 \times I_N$, depending on the current setting
Fuse	electronic
Efficiency	> 98.5 %
Closed circuit current I_0	typ. 3.8 mA
Power dissipation	typ. 0.1 W (No-load operation)
	< 0.7 W (Nominal operation)
Module initialization time	40 ms

PTCB E1 24DC/0.1-0.63A SI-R - Electronic circuit breaker



1441496

<https://www.phoenixcontact.com/us/products/1441496>

Waiting time after switch off of a channel	5 s (at overload / short circuit)
Measuring tolerance I	± 17 % (Depending on the nominal current setting)
Temperature derating	15 A (Total current at 60°C)
	20 A (Total current at 50°C)
MTBF (IEC 61709, SN 29500)	27034333 h (at 25 °C with 21 % load)
	11609008 h (at 40°C with 34.25% load)
	1631800 h (at 60°C with 100% load)
Voltage drop	≤ 0.35 V (Depending on the nominal current setting)
Fail-safe element	4 A DC
Contact switching type	without electrical isolation

Load circuit

Shutdown time	≤ 600 ms
	≥ 12 ms (Depending on the current setting and the available load)
	Shutdown ≤ 1.2 x I _N , depending on the nominal current setting
Undervoltage switch-off	≤ 9.2 V DC (active)
	≥ 10.2 V DC (inactive)
Overvoltage switch-off	≥ 30.5 V DC (active)
	≤ 29.5 V DC (inactive)
Max. capacitive load	4.7 mF (Depending on the current setting and the short-circuit current available)

Reset

Input voltage range	7 V DC ... 30 V DC (Reset with falling edge)
Current consumption	typ. 0.4 mA (at 24 V DC)
Pulse length	≥ 50 ms (High)
	≥ 50 ms (Low)
Voltage	< 5 V DC (Low state)
	> 8 V DC (High state)
Stripping length	8 mm
Conductor cross-section rigid	0.2 mm ² ... 2.5 mm ²
Conductor cross-section AWG	24 ... 12
Conductor cross-section, flexible, with ferrule, with plastic sleeve	0.25 mm ² ... 2.5 mm ²
Conductor cross-section, flexible, with ferrule, without plastic sleeve	0.25 mm ² ... 2.5 mm ²

Status output

Output voltage	24 V DC (Error)
	0 V DC (no error)
Output current	max. 0.015 A (Short-circuit-proof)
Stripping length	8 mm
Conductor cross-section rigid	0.2 mm ² ... 4 mm ²
Conductor cross-section AWG	24 ... 12
Conductor cross-section, flexible, with ferrule, with plastic sleeve	0.25 mm ² ... 2.5 mm ²
Conductor cross-section, flexible, with ferrule, without plastic	0.25 mm ² ... 2.5 mm ²

PTCB E1 24DC/0.1-0.63A SI-R - Electronic circuit breaker



1441496

<https://www.phoenixcontact.com/us/products/1441496>

sleeve

Connection data

Main circuit IN+

Connection method	Push-in connection
Stripping length	8 mm
Conductor cross-section flexible	0.2 mm ² ... 2.5 mm ²
Conductor cross-section rigid	0.2 mm ² ... 4 mm ²
Conductor cross-section AWG	24 ... 12
Conductor cross-section, flexible, with ferrule, with plastic sleeve	0.2 mm ² ... 2.5 mm ²
Conductor cross-section, flexible, with ferrule, without plastic sleeve	0.2 mm ² ... 2.5 mm ²

Main circuit IN-

Connection method	Push-in connection
Stripping length	8 mm
Conductor cross-section flexible	0.2 mm ² ... 2.5 mm ²
Conductor cross-section rigid	0.2 mm ² ... 4 mm ²
Conductor cross-section AWG	24 ... 12
Conductor cross-section, flexible, with ferrule, with plastic sleeve	0.2 mm ² ... 2.5 mm ²
Conductor cross-section, flexible, with ferrule, without plastic sleeve	0.2 mm ² ... 2.5 mm ²

Main circuit OUT

Connection method	Push-in connection
Stripping length	8 mm
Conductor cross-section flexible	0.2 mm ² ... 2.5 mm ²
Conductor cross-section rigid	0.2 mm ² ... 4 mm ²
Conductor cross-section AWG	24 ... 12
Conductor cross-section, flexible, with ferrule, with plastic sleeve	0.2 mm ² ... 2.5 mm ²
Conductor cross-section, flexible, with ferrule, without plastic sleeve	0.2 mm ² ... 2.5 mm ²

Signaling

Channel LED off	off (Channel switched off)
Channel LED yellow	flashing (Programming mode active)
Channel LED green	lit (Channel switched on)
Channel LED red	lit (Channel switched off, over- or undervoltage active)
	ON temporarily (Channel switched off, 5 s cool-down phase, overload or short-circuit release)
	flashing (Channel switched off, ready to be switched back on, overload or short-circuit release)
	flashing quickly (Channel switched off, external voltage at the output, possible installation error)

Dimensions

PTCB E1 24DC/0.1-0.63A SI-R - Electronic circuit breaker



1441496

<https://www.phoenixcontact.com/us/products/1441496>

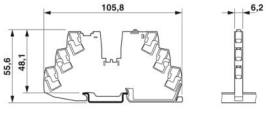
Dimensional drawing	
Width	6.2 mm
Height	105.8 mm
Depth	55.6 mm (incl. DIN rail 7.5 mm)

Material specifications

Color	gray (RAL 7042)
Material	PBT
	PBT
Flammability rating according to UL 94	V-0

Environmental and real-life conditions

Ambient conditions

Degree of protection	IP20
Ambient temperature (operation)	-30 °C ... 60 °C
Ambient temperature (storage/transport)	-40 °C ... 70 °C
Altitude	≤ 3000 m up to 52 °C (amsl) ≤ 4000 m up to 46 °C (amsl)
Humidity test	96 h, 95 % RH, 40 °C
Shock (operation)	30g (IEC 60068-2-27, Test Ea)
Vibration (operation)	10 Hz ... 59.6 Hz (Amplitude ±0.35 mm; in accordance with IEC 60068-2-6, Test Fc) 59.6 Hz ... 150 Hz (Acceleration 5g; in accordance with IEC 60068-2-6, Test Fc) 5 Hz ... 100 Hz (Resonance search 4g; resonance frequency 4g; 90 min in accordance with DNV GL Class B)

Approvals

UL approval

Identification	UL/C-UL Listed UL 508 UL Recognized UL 2367 NEC Class 2 according to UL 1310 UL/C-UL Listed ANSI/UL 121201 Class I, Division 2, Groups A, B, C, D (Hazardous Location)
----------------	---

DNV GL

Identification	Shipbuilding approval
----------------	-----------------------

Corrosive gas test

Identification	ISA S71.04.2013 G3 Harsh Group A
----------------	----------------------------------

Shipbuilding data

PTCB E1 24DC/0.1-0.63A SI-R - Electronic circuit breaker



1441496

<https://www.phoenixcontact.com/us/products/1441496>

Temperature	A
Humidity	B
Vibration	B
EMC	A
Enclosure	A

Standards and regulations

Standards/specifications	EN 61000-6-2
Note	EMC – Immunity for industrial areas
Standards/specifications	EN 61000-6-3
Note	EMC – Emission for residential, business and commercial properties and small operations
Standards/specifications	EN 60068-2-78
Note	Environmental influences – Moisture and heat, constant
Standards/specifications	EN 50178
Note	Equipping power installations with electronic equipment
Standards/specifications	EN 60068-2-6
Note	Environmental influences – Vibrations (sinusoidal)
Standards/specifications	EN 60068-2-27
Note	Environmental influences – Shocks
Standards/specifications	EN 60068-2-30
Note	Environmental influences – Part 2–30: Tests – Test Db: Damp heat, cyclical

Mounting

Mounting type	DIN rail: 35 mm
---------------	-----------------

PTCB E1 24DC/0.1-0.63A SI-R - Electronic circuit breaker



1441496

<https://www.phoenixcontact.com/us/products/1441496>

Drawings

Dimensional drawing



Diagram



Total current input

PTCB E1 24DC/0.1-0.63A SI-R - Electronic circuit breaker



1441496

<https://www.phoenixcontact.com/us/products/1441496>

Block diagram



PTCB E1 24DC/0.1-0.63A SI-R - Electronic circuit breaker



1441496

<https://www.phoenixcontact.com/us/products/1441496>

Approvals

To download certificates, visit the product detail page: <https://www.phoenixcontact.com/us/products/1441496>



UL Recognized

Approval ID: E317172-20170817



UL Listed

Approval ID: E123528-20170530



cUL Listed

Approval ID: E123528-20170530



DNV GL

Approval ID: TAE00003UT



UL Recognized

Approval ID: E324415-20201030



cUL Listed

Approval ID: E483407-20201030



UL Listed

Approval ID: E483407-20201030

PTCB E1 24DC/0.1-0.63A SI-R - Electronic circuit breaker



1441496

<https://www.phoenixcontact.com/us/products/1441496>

Classifications

ECLASS

ECLASS-13.0	27140401
ECLASS-15.0	27140401

ETIM

ETIM 10.0	EC003538
-----------	----------

UNSPSC

UNSPSC 21.0	39121400
-------------	----------

PTCB E1 24DC/0.1-0.63A SI-R - Electronic circuit breaker



1441496

<https://www.phoenixcontact.com/us/products/1441496>

Environmental product compliance

EU RoHS

Fulfills EU RoHS substance requirements	Yes
Exemption	7(a), 7(c)-I

China RoHS

Environment friendly use period (EFUP)	EFUP-50
	An article-related China RoHS declaration table can be found in the download area for the respective article under "Manufacturer declaration". For all articles with EFUP-E, no China RoHS declaration table issued and required.

EU REACH SVHC

REACH candidate substance (CAS No.)	Lead(CAS: 7439-92-1)
SCIP	cf47d7c7-d5b4-4827-9ac0-14146b0c2dd8

EF3.1 Climate Change

CO2e kg	1.195 kg CO2e
---------	---------------

Phoenix Contact 2026 © - all rights reserved
<https://www.phoenixcontact.com>

Phoenix Contact USA
586 Fulling Mill Road
Middletown, PA 17057, United States
(+717) 944-1300
info@phoenixcon.com