

HC-M-ADP-EMC - Adapter

1420486

<https://www.phoenixcontact.com/us/products/1420486>

Please be informed that the data shown in this PDF document is generated from our online catalog. Please find the complete data in the user documentation. Our general terms of use for downloads are valid.



Adapter, application: Shield adapters

Commercial data

| | |
|--------------------------------------|---------------|
| Item number | 1420486 |
| Packing unit | 1 pc |
| Minimum order quantity | 1 pc |
| Sales key | BF62 |
| Product key | AF7ACZ |
| GTIN | 4055626225272 |
| Weight per piece (including packing) | 20.3 g |
| Weight per piece (excluding packing) | 20.7 g |
| Customs tariff number | 85389099 |
| Country of origin | AT |

HC-M-ADP-EMC - Adapter

1420486

<https://www.phoenixcontact.com/us/products/1420486>



Technical data

Product properties

| | |
|--------------|-----------------|
| Product type | Adapter |
| Application | Shield adapters |

Environmental and real-life conditions

Ambient conditions

| | |
|---------------------------------|------------------|
| Ambient temperature (operation) | -40 °C ... 85 °C |
|---------------------------------|------------------|

HC-M-ADP-EMC - Adapter

1420486

<https://www.phoenixcontact.com/us/products/1420486>



Drawings

Dimensional drawing

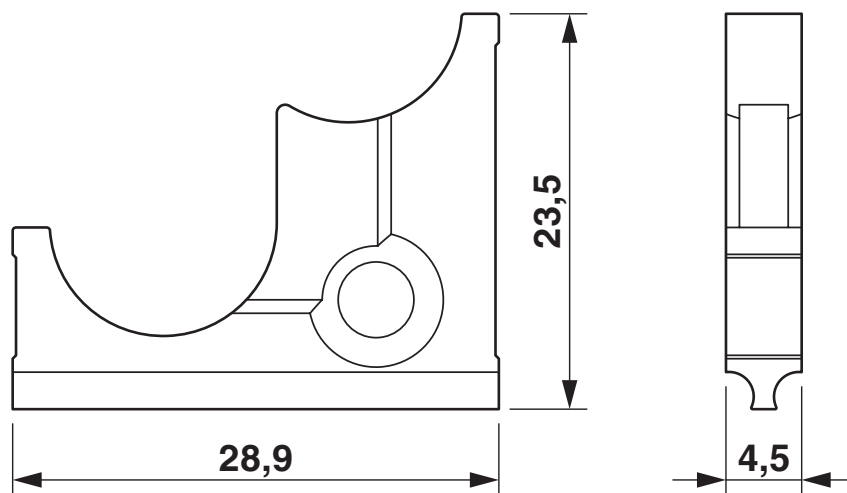

Dimensional drawing

HC-M-ADP-EMC - Adapter

1420486

<https://www.phoenixcontact.com/us/products/1420486>



Classifications

ECLASS

| | |
|-------------|----------|
| ECLASS-13.0 | 27440192 |
| ECLASS-15.0 | 27440192 |

ETIM

| | |
|-----------|----------|
| ETIM 10.0 | EC002943 |
|-----------|----------|

UNSPSC

| | |
|-------------|----------|
| UNSPSC 21.0 | 39121400 |
|-------------|----------|

HC-M-ADP-EMC - Adapter



1420486

<https://www.phoenixcontact.com/us/products/1420486>

Environmental product compliance

EU RoHS

| | |
|---|--------------------|
| Fulfills EU RoHS substance requirements | Yes, No exemptions |
|---|--------------------|

China RoHS

| | |
|--|--|
| Environment friendly use period (EFUP) | EFUP-E |
| | No hazardous substances above the limits |

EU REACH SVHC

| | |
|-------------------------------------|----------------------------|
| REACH candidate substance (CAS No.) | No substance above 0.1 wt% |
|-------------------------------------|----------------------------|

Phoenix Contact 2026 © - all rights reserved
<https://www.phoenixcontact.com>

Phoenix Contact USA
586 Fulling Mill Road
Middletown, PA 17057, United States
(+717) 944-1300
info@phoenixcon.com