

# QPD P 3X1,5 4-9 BK - Connector



1419424

<https://www.phoenixcontact.com/us/products/1419424>

Please be informed that the data shown in this PDF document is generated from our online catalog. Please find the complete data in the user documentation. Our general terms of use for downloads are valid.



Connector, connection method: IDC connection, 0.5 mm<sup>2</sup> ... 1.5 mm<sup>2</sup>, 690 V, 17.5 A, PA, black, with QUICKON nut, coding: Coding profile, external cable diameter: 5 mm ... 7 mm and 7 mm ... 9.5 mm, connection labeling: 1, 2, 3

## Your advantages

- Innovative and time saving - QUICKON fast connection for time saving of up to 80 % for on-site connection
- Robust throughout: housing with IP68/IP69K and IK07 protection for a wide range of applications
- Safer connection with mechanical coding to protect against mismatching, and touch-proof protection in accordance with DIN EN 0105
- Easy maintenance – the connectors enable fast device replacement and preassembled cables simplify startup

## Commercial data

Item number	1419424
Packing unit	1 pc
Minimum order quantity	1 pc
Sales key	BF50
Product key	AF6BAA
GTIN	4055626173030
Weight per piece (including packing)	39.6 g
Weight per piece (excluding packing)	38.2 g
Customs tariff number	85366990
Country of origin	PL

# QPD P 3X1,5 4-9 BK - Connector



1419424

<https://www.phoenixcontact.com/us/products/1419424>

## Technical data

### Product properties

Product type	Installation connector
Product family	QPD
Type	QPD 3x1,5
Number of positions	3
Position marking	1, 2, 3
Number of connections	3
Coding	Coding profile

### Insulation characteristics

Overvoltage category	III
Degree of pollution	3

### Electrical properties

Rated surge voltage (II/2)	8 kV
Rated surge voltage (III/2)	8 kV
Rated surge voltage (III/3)	6 kV
Rated current	17.5 A
Contact resistance	< 3 mΩ
rated voltage (II/2)	1000 V
rated voltage (III/2)	1000 V
Rated voltage (III/3)	690 V
Nominal voltage $U_N$	690 V
Nominal current $I_N$	17.5 A

### Connection data

#### Connection technology

Connection method On the field side	IDC connection
Frequency of connections between conductors of the same cross section	max. 10

#### Conductor connection

Conductor cross-section flexibel	0.5 mm <sup>2</sup> ... 1.5 mm <sup>2</sup>
Conductor cross-section solid	0.5 mm <sup>2</sup> ... 1.5 mm <sup>2</sup>
Connection cross section AWG	20 ... 16
Tightening torque Union nut	8 Nm
Tightening torque Locking nut	5 Nm

### Dimensions

# QPD P 3X1,5 4-9 BK - Connector

1419424

<https://www.phoenixcontact.com/us/products/1419424>

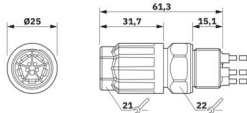
Dimensional drawing	
Width	25 mm
Height	25 mm
Length	70.8 mm
Diameter	25 mm

## Material specifications

Color	black (RAL 9005)
Material Housing	PA
Material Contact	Cu
Material Contact surface	silver-plated
Flammability rating according to UL 94	V0
Material wire insulation	PVC/PE/TPE/rubber

## Cable/line

Structure of individual litz in acc. with VDE 0295 / smallest wire diameter	VDE 0295 class 1 to 6/min. 0.15 mm
External cable diameter	5 mm ... 7 mm
	7 mm ... 9.5 mm
Wire diameter including insulation	1.6 mm ... 3 mm
Position marking	1, 2, 3
Material wire insulation	PVC/PE/TPE/rubber

## Mechanical properties

### Mechanical data

Insertion/withdrawal cycles	max. 50
-----------------------------	---------

## Environmental and real-life conditions

### Ambient conditions

Degree of protection	IP66
	IP68
	IP69K
	Touch-proof when not plugged in (IP2X)
Impact strength	IK07
Ambient temperature (operation)	-40 °C ... 100 °C
Temperature when conductor connected	-5 °C ... 50 °C
Ambient temperature (storage/transport)	-40 °C ... 100 °C

# QPD P 3X1,5 4-9 BK - Connector

1419424

<https://www.phoenixcontact.com/us/products/1419424>

## Drawings

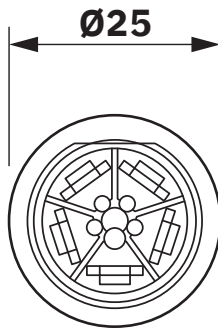

Dimensional drawing

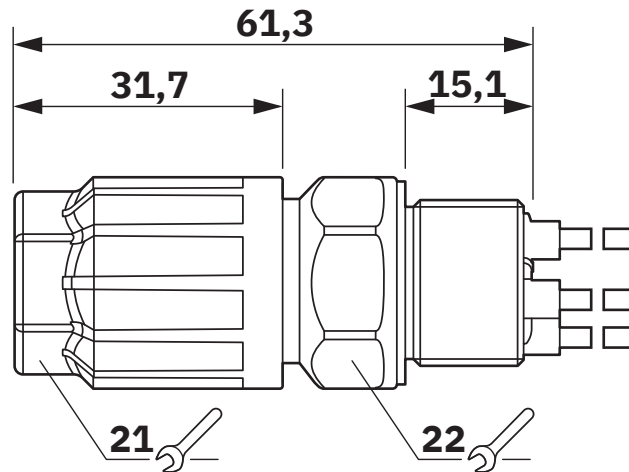

Dimensional drawing

# QPD P 3X1,5 4-9 BK - Connector





1419424

<https://www.phoenixcontact.com/us/products/1419424>

## Approvals

To download certificates, visit the product detail page: <https://www.phoenixcontact.com/us/products/1419424>

 <b>UL Listed</b> Approval ID: E468743				
	Nominal voltage $U_N$	Nominal current $I_N$	Cross section AWG	Cross section $\text{mm}^2$
keine				
	600 V	8 A	- 16	-

 <b>cUL Listed</b> Approval ID: E468743				
	Nominal voltage $U_N$	Nominal current $I_N$	Cross section AWG	Cross section $\text{mm}^2$
keine				
	600 V	8 A	- 16	-

 <b>DNV GL</b> Approval ID: TAE00003J5				
--	--	--	--	--

# QPD P 3X1,5 4-9 BK - Connector



1419424

<https://www.phoenixcontact.com/us/products/1419424>

## Classifications

### ECLASS

ECLASS-13.0	27440605
ECLASS-15.0	27440605

### ETIM

ETIM 10.0	EC002560
-----------	----------

### UNSPSC

UNSPSC 21.0	39121400
-------------	----------

# QPD P 3X1,5 4-9 BK - Connector



1419424

<https://www.phoenixcontact.com/us/products/1419424>

## Environmental product compliance

### EU RoHS

Fulfills EU RoHS substance requirements	Yes, No exemptions
---	--------------------

### China RoHS

Environment friendly use period (EFUP)	EFUP-E
	No hazardous substances above the limits

### EU REACH SVHC

REACH candidate substance (CAS No.)	Triphenyl phosphate(CAS: 115-86-6)
-------------------------------------	------------------------------------

Phoenix Contact 2026 © - all rights reserved  
<https://www.phoenixcontact.com>

Phoenix Contact USA  
586 Fulling Mill Road  
Middletown, PA 17057, United States  
(+717) 944-1300  
[info@phoenixcon.com](mailto:info@phoenixcon.com)