

HC-M-02-AT-F-10 - Contact insert module



1417387

<https://www.phoenixcontact.com/us/products/1417387>

Please be informed that the data shown in this PDF document is generated from our online catalog. Please find the complete data in the user documentation. Our general terms of use for downloads are valid.



Contact insert module, number of positions: 2, power contacts: 2, control contacts: 0, Socket, Axial screw connection, 690 V, 40 A, 2.5 mm² ... 10 mm², application: Power

Commercial data

| | |
|--------------------------------------|---------------|
| Item number | 1417387 |
| Packing unit | 2 pc |
| Minimum order quantity | 2 pc |
| Sales key | BF62 |
| Product key | AF7ACE |
| GTIN | 4055626112688 |
| Weight per piece (including packing) | 27.35 g |
| Weight per piece (excluding packing) | 24.95 g |
| Customs tariff number | 85366990 |
| Country of origin | PL |

Technical data

Notes

| | |
|---------|---|
| General | For HEAVYCON HC-B6 to B48 housing, snap-in module frame required, axial connection for 2 mm Allen key |
| General | Connectors may be operated only when there is no load/voltage. |
| General | The axial screw connection must be established using a 2 mm Allen key (for stranded conductors only) |

Mounting

| | |
|------------------|--|
| Assembly note | To ensure correct use, installation in housing with IP54 protection or better is required |
| | <p>Note regarding axial connection technology:</p> <p>Only for stranded wires. The specified conductor cross-sections refer to the geometric cross section of the cable used. Cables with a geometric cross section which deviates significantly from the nominal cable cross section must be checked before use.</p> <p>The axial connection technology connection space is designed for fine strand cables according to VDE 0295 Class 5. Deviating cable structures (e.g., Class 6 cables) must be checked before use.</p> <p>Assembly instructions</p> <p>Before assembly, ensure that the tapered screw is fully loosened (chamber is open). Cables must not be twisted. The wires must be pushed into the contact chamber as far as they will go (until the insulation touches the contact). Hold the wires in position and tighten using an Allen key. The used wire end must be cut off before reconnection. The terminal screw must only be retightened once to prevent the litz wires from breaking. To prevent damage to the contact, the wire/cable must be mechanically held at an appropriate distance from the connection point (e.g., when used in a plate cut out). For notes on correct execution, see DIN VDE 0100-520:2003-06. Unused connections must be tightened with maximum torque.</p> |
| Hexagonal socket | SW 2 |

Product properties

| | |
|-------------------------|------------------------|
| Product type | Modular contact insert |
| Series | HC-M-02 |
| Application | Power |
| Number of positions | 2 |
| Connection profile | 2 |
| Contact numbering | 1 - 2 |
| Number of module slots | 1 |
| No. of power contacts | 2 |
| No. of control contacts | 0 |

Insulation characteristics

HC-M-02-AT-F-10 - Contact insert module



1417387

<https://www.phoenixcontact.com/us/products/1417387>

| | |
|----------------------|-----|
| Overvoltage category | III |
| Degree of pollution | 3 |

Connection data

Connection technology

| | |
|----------------------------------|------------------------|
| Connection technology | Axial screw connection |
| Connection in acc. with standard | IEC / EN |

Conductor connection

| | |
|---|--|
| Conductor cross-section | 2.5 mm ² ... 10 mm ² (The cross section specification refers to the geometric cross section of the cable used) |
| Connection cross section AWG | 12 ... 10 |
| Tightening torque | 1.5 Nm (2.5 mm ² ... 4 mm ²) 2 Nm (6 mm ² ... 10 mm ²) |
| Stripping length of the individual wire | 9 mm (with an outside conductor diameter up to 4.8 mm) 11 mm (with an outside conductor diameter up to 6.5 mm) |

Dimensions

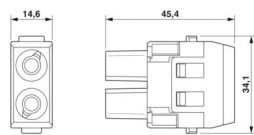
| | |
|---------------------|--|
| Dimensional drawing |  |
| Width | 34.2 mm |
| Height | 33.5 mm |
| Length | 14.6 mm |

Mechanical characteristics

| | |
|------------------|------|
| Contact diameter | 4 mm |
|------------------|------|

Electrical properties

| | |
|--------------------------------|----------------|
| Rated voltage (III/2) contacts | 1000 V |
| Rated voltage (III/3) | 690 V |
| Rated surge voltage (III/2) | 8 kV |
| Rated surge voltage (III/3) | 8 kV |
| Rated surge voltage | 8 kV |
| Rated current | 40 A |
| SCCR | 5 kA (UL 2237) |

Mechanical properties

Mechanical data

| | |
|-----------------------------|-------|
| Insertion/withdrawal cycles | ≥ 500 |
|-----------------------------|-------|

Material specifications

| | |
|--|----|
| Flammability rating according to UL 94 | V0 |
|--|----|

HC-M-02-AT-F-10 - Contact insert module



1417387

<https://www.phoenixcontact.com/us/products/1417387>

| | |
|--------------------------|--------------|
| Contact material | Copper alloy |
| Contact surface material | Ag |
| Contact carrier material | PC |
| Standards/regulations | PC |

Environmental and real-life conditions

Ambient conditions

| | |
|---------------------------------|-------------------|
| Ambient temperature (operation) | -40 °C ... 125 °C |
|---------------------------------|-------------------|

Standards and regulations

Testing

| | |
|-----------------------|---|
| Standards/regulations | PC: Fire protection in rail vehicles - requirement sets R22, R23, and R24 acc. to DIN EN 45545-2 (Risk level HL1 - HL3) |
|-----------------------|---|

HC-M-02-AT-F-10 - Contact insert module



1417387

<https://www.phoenixcontact.com/us/products/1417387>

Drawings

Dimensional drawing

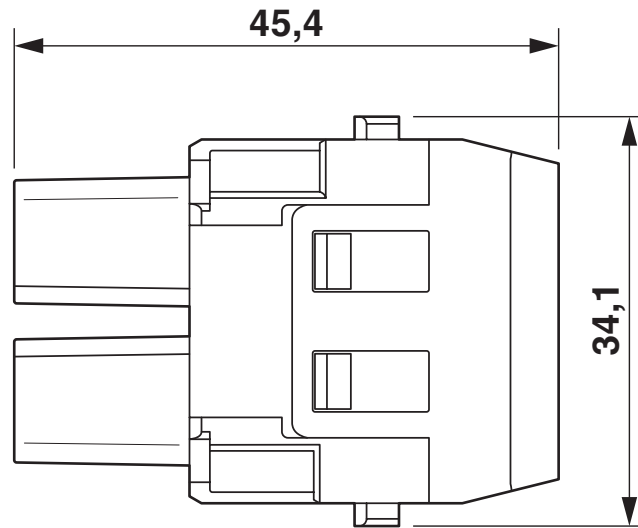
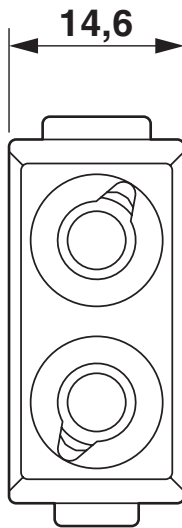

Female insert

HC-M-02-AT-F-10 - Contact insert module

1417387

<https://www.phoenixcontact.com/us/products/1417387>

Schematic diagram

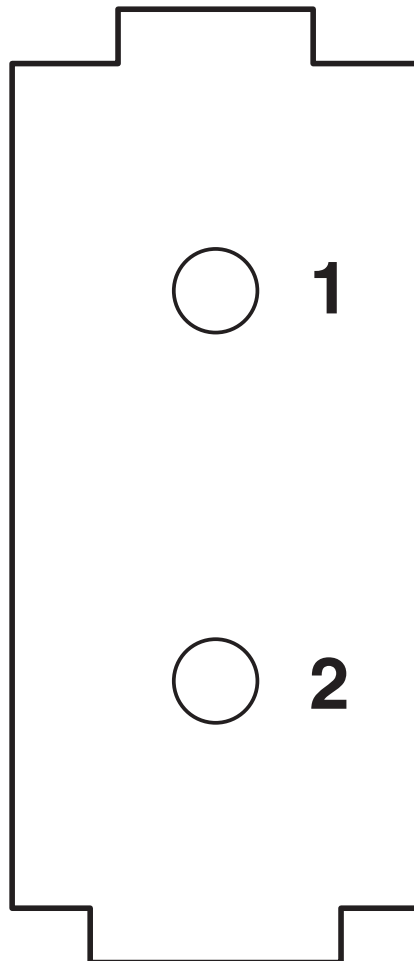

Connector pin assignment

HC-M-02-AT-F-10 - Contact insert module

1417387

<https://www.phoenixcontact.com/us/products/1417387>

Schematic diagram



Axial connection (2 mm Allen key)

Diagram

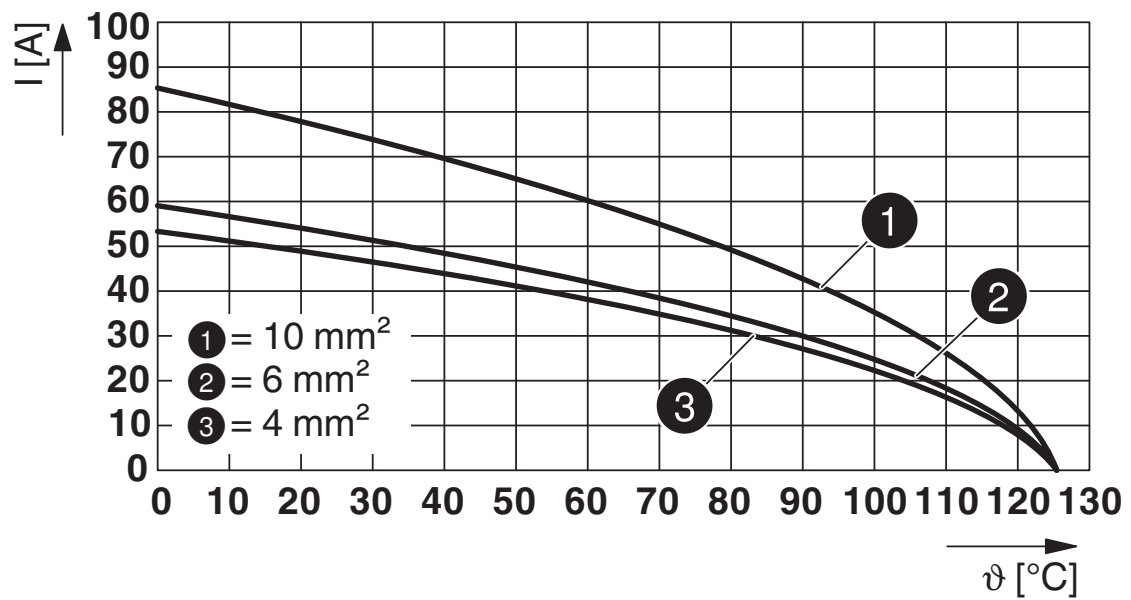

Derating diagram

HC-M-02-AT-F-10 - Contact insert module



1417387

<https://www.phoenixcontact.com/us/products/1417387>

Approvals

To download certificates, visit the product detail page: <https://www.phoenixcontact.com/us/products/1417387>

DNV

Approval ID: TAE000037S



CSA

Approval ID: 158887

| | Nominal voltage U_N | Nominal current I_N | Cross section AWG | Cross section mm^2 |
|-------|-----------------------|-----------------------|-------------------|-----------------------------|
| keine | | | | |
| | 600 V | 45 A | - 8 | - |



UL Recognized

Approval ID: E118976

| | Nominal voltage U_N | Nominal current I_N | Cross section AWG | Cross section mm^2 |
|-------|-----------------------|-----------------------|-------------------|-----------------------------|
| keine | | | | |
| | 600 V | 55 A | - 8 | - |



UL Recognized

Approval ID: E468743

| | Nominal voltage U_N | Nominal current I_N | Cross section AWG | Cross section mm^2 |
|-------|-----------------------|-----------------------|-------------------|-----------------------------|
| keine | | | | |
| | 600 V | 55 A | - | - |

HC-M-02-AT-F-10 - Contact insert module



1417387

<https://www.phoenixcontact.com/us/products/1417387>

Classifications

ECLASS

| | |
|-------------|----------|
| ECLASS-13.0 | 27440217 |
| ECLASS-15.0 | 27440217 |

ETIM

| | |
|-----------|----------|
| ETIM 10.0 | EC000438 |
|-----------|----------|

UNSPSC

| | |
|-------------|----------|
| UNSPSC 21.0 | 39121400 |
|-------------|----------|

HC-M-02-AT-F-10 - Contact insert module



1417387

<https://www.phoenixcontact.com/us/products/1417387>

Environmental product compliance

EU RoHS

| | |
|---|--------------------|
| Fulfills EU RoHS substance requirements | Yes, No exemptions |
|---|--------------------|

China RoHS

| | |
|--|--|
| Environment friendly use period (EFUP) | EFUP-E |
| | No hazardous substances above the limits |

EU REACH SVHC

| | |
|-------------------------------------|----------------------------|
| REACH candidate substance (CAS No.) | No substance above 0.1 wt% |
|-------------------------------------|----------------------------|

EF3.1 Climate Change

| | |
|---------|---------------|
| CO2e kg | 0.164 kg CO2e |
|---------|---------------|

Phoenix Contact 2026 © - all rights reserved
<https://www.phoenixcontact.com>

Phoenix Contact USA
586 Fulling Mill Road
Middletown, PA 17057, United States
(+717) 944-1300
info@phoenixcon.com