

HC-D 15-TFL-53/O1M20G - Housing



1416379

<https://www.phoenixcontact.com/us/products/1416379>

Please be informed that the data shown in this PDF document is generated from our online catalog. Please find the complete data in the user documentation. Our general terms of use for downloads are valid.



Sleeve housing D15, for single locking latch, material: Die-cast aluminum, cable outlets: 1, straight, 1x M20, height: 55 mm, cable gland: none, Standard

Commercial data

Item number	1416379
Packing unit	10 pc
Minimum order quantity	1 pc
Product key	AF7AAE
GTIN	4055626072418
Weight per piece (including packing)	115.6 g
Weight per piece (excluding packing)	88 g
Country of origin	DE

HC-D 15-TFL-53/O1M20G - Housing

1416379

<https://www.phoenixcontact.com/us/products/1416379>

Technical data

Product properties

Product type	Housing with locking latch
Housing type	Sleeve housing
Application	Standard
Type	D15
No. of cable outlets	1
Type of the screw connection	1x M20
Cable outlet	straight
Pg screw connection	none

Dimensions

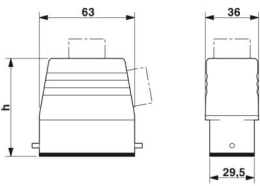
Dimensional drawing	
Width	36 mm
Height	55 mm
Length	63 mm

Material specifications

Seal material	NBR
Housing material	Die-cast aluminum
Housing surface material	Powder-coated, gray

Mechanical properties

Mechanical data

Type of the screw connection	1x M20
Locking type	Pin

Environmental and real-life conditions

Ambient conditions

Degree of protection	IP65
Ambient temperature (operation)	-40 °C ... 125 °C

HC-D 15-TFL-53/O1M20G - Housing

1416379

<https://www.phoenixcontact.com/us/products/1416379>



Drawings

Dimensional drawing

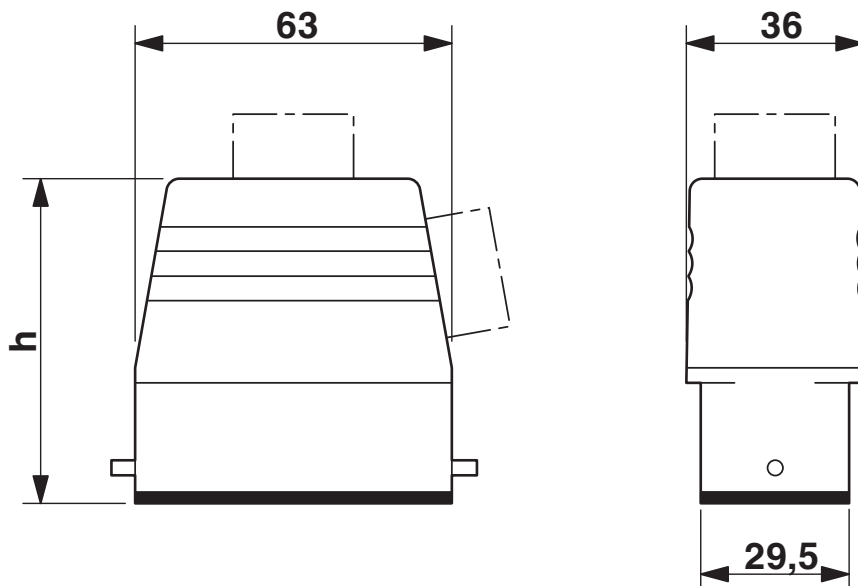

Dimensional drawing

HC-D 15-TFL-53/O1M20G - Housing



1416379

<https://www.phoenixcontact.com/us/products/1416379>

Classifications

ECLASS

ECLASS-13.0	27440202
ECLASS-15.0	27440202

HC-D 15-TFL-53/O1M20G - Housing



1416379

<https://www.phoenixcontact.com/us/products/1416379>

Environmental product compliance

EU RoHS

Fulfills EU RoHS substance requirements	Yes, No exemptions
---	--------------------

China RoHS

Environment friendly use period (EFUP)	EFUP-E
	No hazardous substances above the limits

EU REACH SVHC

REACH candidate substance (CAS No.)	No substance above 0.1 wt%
-------------------------------------	----------------------------

Phoenix Contact 2026 © - all rights reserved
<https://www.phoenixcontact.com>

Phoenix Contact USA
586 Fulling Mill Road
Middletown, PA 17057, United States
(+717) 944-1300
info@phoenixcon.com