

SAC-5P- 1,5-PVC/AD-2L - Sensor/actuator cable



1415945

<https://www.phoenixcontact.com/us/products/1415945>

Please be informed that the data shown in this PDF document is generated from our online catalog. Please find the complete data in the user documentation. Our general terms of use for downloads are valid.



Sensor/actuator cable, 5-position, PVC, black, free cable end, on Valve connector AD (pressure switch), with 2 LEDs, Wiring: unwired, cable length: 1.5 m

Your advantages

- Easy and safe: 100 % electrically tested plug-in components

Commercial data

Item number	1415945
Packing unit	1 pc
Minimum order quantity	1 pc
Sales key	BF07
Product key	AF1DBA
GTIN	4055626055206
Weight per piece (including packing)	107.9 g
Weight per piece (excluding packing)	80.15 g
Customs tariff number	85444290
Country of origin	PL

1415945

<https://www.phoenixcontact.com/us/products/1415945>

Technical data

Product properties

Product type	Sensor/actuator cable with valve connector
Application	Standard
Number of positions	5
No. of cable outlets	1
Shielded	no

Insulation characteristics

Overvoltage category	III
Degree of pollution	3

Material specifications

Flammability rating according to UL 94	V0
Seal material	TPU
Material housing valve plug	TPU
Contact material	CuSn
Valve plug contact insert material	PA 6
Contact surface material	Sn

Electrical properties

Insulation resistance	$\geq 100 \text{ M}\Omega$
Nominal voltage U_N	24 V DC
Nominal current I_N	4 A

Valve connector characteristics

Fixing screws	M3 x 29
---------------	---------

Signaling

Status display	2 LEDs
Status display present	yes

Connector

Connection 1

Type	free cable end
------	----------------

Connection 2

Type	Valve connector AD (pressure switch)
Material	CuSn (Contact)
	Sn (Contact surface)
	PA 6 (Contact carrier)
	TPU (Housing)
Protective circuit	unwired

SAC-5P- 1,5-PVC/AD-2L - Sensor/actuator cable



1415945

<https://www.phoenixcontact.com/us/products/1415945>

Cable/line

Cable length	1.5 m
--------------	-------

PVC black [PVC]

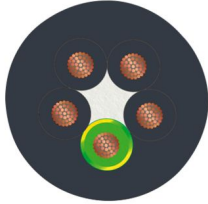
Dimensional drawing	
Cable weight	58.7 kg/km
UL AWM Style	2464
Number of positions	5
Shielded	no
Cable type	PVC black [PVC]
Conductor structure signal line	16x 0.20 mm
AWG signal line	20
Conductor cross-section	5x 0.5 mm ²
Wire diameter incl. insulation	1.5 mm ±0.05 mm
External cable diameter	5.60 mm ±0.2 mm
Outer sheath, material	PVC
External sheath, color	black
Conductor material	Bare Cu litz wires
Material wire insulation	PVC
Single wire, color	black 1, black 2, black 3, black 4, green/yellow
Overall twist	5 cores, twisted
Max. conductor resistance	39 Ω/km (at 20 °C)
Insulation resistance	≥ 20 MΩ*km
Nominal voltage, cable	300 V
Test voltage	1200 V
Minimum bending radius, fixed installation	5 x D
Smallest bending radius, fixed installation	28 mm
Flame resistance	DIN VDE 0482 DIN EN 50265-2-1
Resistance to oil	largely oil-resistant
Ambient temperature (operation)	-40 °C ... 80 °C (cable, fixed installation) -5 °C ... 80 °C (Cable, flexible installation)

Environmental and real-life conditions

Ambient conditions

Degree of protection	IP65
----------------------	------

SAC-5P- 1,5-PVC/AD-2L - Sensor/actuator cable



1415945

<https://www.phoenixcontact.com/us/products/1415945>

	IP67
Ambient temperature (operation) (Valve connector)	-20 °C ... 85 °C (Valve connector)

Standards and regulations

Valve connector

Standard designation	Valve connector
Standards/specifications	EN 175301-803

SAC-5P- 1,5-PVC/AD-2L - Sensor/actuator cable

1415945

<https://www.phoenixcontact.com/us/products/1415945>

Drawings

Dimensional drawing



Valve connector, type AD

Dimensional drawing

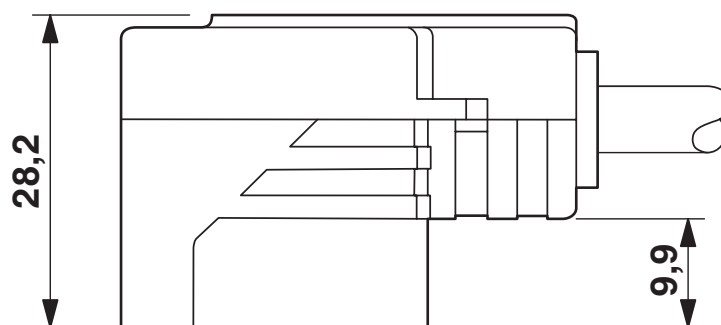

Valve connector, type AD, side view

SAC-5P- 1,5-PVC/AD-2L - Sensor/actuator cable

1415945

<https://www.phoenixcontact.com/us/products/1415945>

Schematic diagram



Valve plug connector pin assignment, type AD

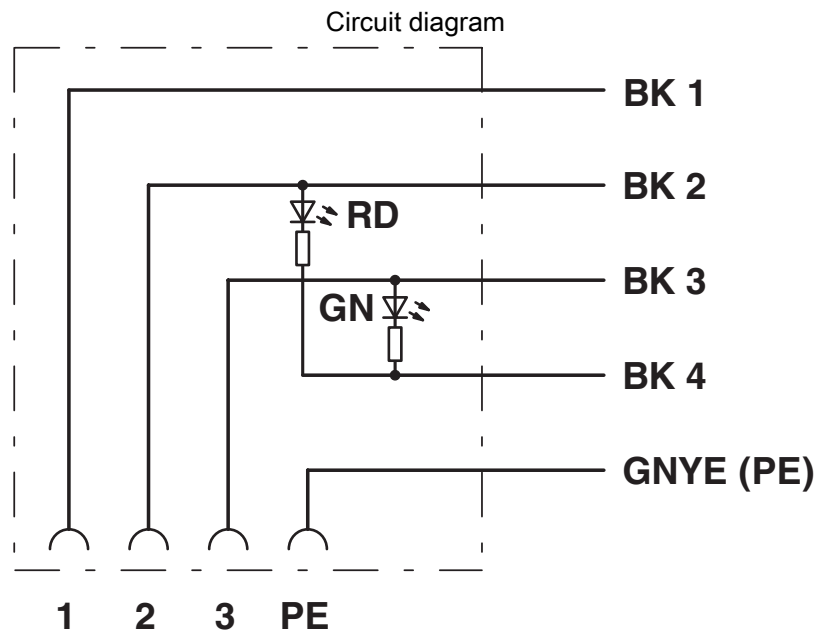

Contact assignment of the valve plug

SAC-5P- 1,5-PVC/AD-2L - Sensor/actuator cable



1415945

<https://www.phoenixcontact.com/us/products/1415945>

Approvals

To download certificates, visit the product detail page: <https://www.phoenixcontact.com/us/products/1415945>



EAC-RoHS

Approval ID: RU D-DE.HB35.B.00387



CSAus

Approval ID: 13631

	Nominal voltage U_N	Nominal current I_N	Cross section AWG	Cross section mm^2
keine				
	24 V	4 A	-	-

SAC-5P- 1,5-PVC/AD-2L - Sensor/actuator cable



1415945

<https://www.phoenixcontact.com/us/products/1415945>

Classifications

ECLASS

ECLASS-13.0	27060312
ECLASS-15.0	27060312

ETIM

ETIM 10.0	EC001855
-----------	----------

UNSPSC

UNSPSC 21.0	31251500
-------------	----------

SAC-5P- 1,5-PVC/AD-2L - Sensor/actuator cable



1415945

<https://www.phoenixcontact.com/us/products/1415945>

Environmental product compliance

EU RoHS

Fulfills EU RoHS substance requirements	Yes, No exemptions
---	--------------------

China RoHS

Environment friendly use period (EFUP)	EFUP-E
	No hazardous substances above the limits

EU REACH SVHC

REACH candidate substance (CAS No.)	No substance above 0.1 wt%
-------------------------------------	----------------------------

EF3.1 Climate Change

CO2e kg	1.028 kg CO2e
---------	---------------

Phoenix Contact 2026 © - all rights reserved
<https://www.phoenixcontact.com>

Phoenix Contact USA
586 Fulling Mill Road
Middletown, PA 17057, United States
(+717) 944-1300
info@phoenixcon.com