

QPD W 2PE1,5 4-9 M20 FC BK - Panel feed-through



1414686

<https://www.phoenixcontact.com/us/products/1414686>

Please be informed that the data shown in this PDF document is generated from our online catalog. Please find the complete data in the user documentation. Our general terms of use for downloads are valid.



Panel feed-through, connection method: Spade connection (For slip-on sleeves according to DIN 46247-2)/ IDC connection, number of positions: 2+PE, M20, Pin, 0.5 mm² ... 1.5 mm², 690 V, 17.5 A, PA, black, with QUICKON nut, coding: Coding profile, external cable diameter: 5 mm .. 7 mm and 7 mm ... 9.5 mm, 1.5 mm²

Your advantages

- Innovative and time saving - QUICKON fast connection for time saving of up to 80 % for on-site connection
- Robust throughout: housing with IP68/IP69K and IK07 protection for a wide range of applications
- Safer connection with mechanical coding to protect against mismatching, and touch-proof protection in accordance with DIN EN 0105
- Efficient - by using panel feed-throughs, devices no longer need to be opened in order to connect cables

Commercial data

Item number	1414686
Packing unit	1 pc
Minimum order quantity	1 pc
Sales key	BF50
Product key	AF6AAA
GTIN	4055626031392
Weight per piece (including packing)	31.871 g
Weight per piece (excluding packing)	30.998 g
Customs tariff number	85366990
Country of origin	PL

QPD W 2PE1,5 4-9 M20 FC BK - Panel feed-through



1414686

<https://www.phoenixcontact.com/us/products/1414686>

Technical data

Product properties

Product type	Panel feed-through
Product family	QPD
Type	QPD 3x1,5
Number of positions	3
Connection profile	2+PE
Position marking	1, 2, PE
Number of connections	10
Number of connections per position	1
Coding	Coding profile

Insulation characteristics

Overvoltage category	III
Degree of pollution	3

Connection data

Connection technology

Connection method On the device side	Spade connection (For slip-on sleeves according to DIN 46247-2)
Connection method On the field side	IDC connection
Frequency of connections between conductors of the same cross section	max. 10

Conductor connection

Conductor cross-section flexibel	0.5 mm ² ... 1.5 mm ²
Conductor cross-section solid	0.5 mm ² ... 1.5 mm ²
Connection cross section AWG	20 ... 16
Tightening torque Union nut	8 Nm
Tightening torque Locking nut	5 Nm

Dimensions

Dimensional drawing	
Width	25 mm
Height	25 mm
Length	61.3 mm
Diameter	25 mm
Dimensions of slip-on connection	4.8 x 0.8 mm

Electrical properties

QPD W 2PE1,5 4-9 M20 FC BK - Panel feed-through



1414686

<https://www.phoenixcontact.com/us/products/1414686>

Rated surge voltage (II/2)	8 kV
Rated surge voltage (III/2)	8 kV
Rated surge voltage (III/3)	6 kV
Rated current	17.5 A
Contact resistance	< 3 mΩ
rated voltage (II/2)	1000 V
rated voltage (III/2)	1000 V
Rated voltage (III/3)	690 V
Nominal voltage U_N	690 V AC
	690 V DC
Nominal current I_N	17.5 A

Mechanical properties

Mechanical data

Insertion/withdrawal cycles	max. 50
-----------------------------	---------

Material specifications

Color	black (RAL 9005)
Material Housing	PA
Material Contact	Cu
Material Contact surface	silver-plated
Material Seal	NBR
Flammability rating according to UL 94	V0
Material wire insulation	PVC/PE/TPE/rubber

Cable/line

Structure of individual litz in acc. with VDE 0295 / smallest wire diameter	VDE 0295 class 1 to 6/min. 0.15 mm
External cable diameter	5 mm ... 7 mm
	7 mm ... 9.5 mm
Wire diameter including insulation	1.6 mm ... 3 mm
Position marking	1, 2, PE
Cable cross section	1.5 mm ²
Material wire insulation	PVC/PE/TPE/rubber

Mounting

Mounting type	Front mounting M20
---------------	--------------------

Environmental and real-life conditions

Ambient conditions

Degree of protection	IP66
	IP68 (2 m / 24 h)
	IP69K
	Touch-proof when not plugged in (IP2X)

QPD W 2PE1,5 4-9 M20 FC BK - Panel feed-through



1414686

<https://www.phoenixcontact.com/us/products/1414686>

Impact strength	IK07
Ambient temperature (operation)	-40 °C ... 100 °C
Temperature when conductor connected	-5 °C ... 50 °C
Ambient temperature (storage/transport)	-40 °C ... 100 °C

Drawings

Dimensional drawing

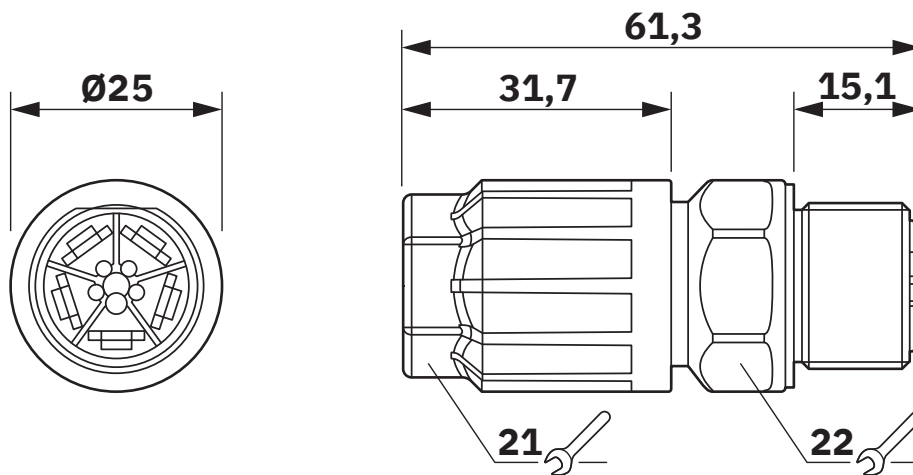

Dimensional drawing



Housing cutout

1414686

<https://www.phoenixcontact.com/us/products/1414686>

Diagram



Derating diagram

QPD W 2PE1,5 4-9 M20 FC BK - Panel feed-through



1414686

<https://www.phoenixcontact.com/us/products/1414686>

Approvals

To download certificates, visit the product detail page: <https://www.phoenixcontact.com/us/products/1414686>



IECEE CB Scheme
Approval ID: DE1-65875



DNV GL
Approval ID: TAE00003J5



VDE Zeichengenehmigung
Approval ID: 40029149



UL Listed
Approval ID: E468743

	Nominal voltage U_N	Nominal current I_N	Cross section AWG	Cross section mm^2
keine				
	600 V	8 A	- 16	- 16



cUL Listed
Approval ID: E468743

	Nominal voltage U_N	Nominal current I_N	Cross section AWG	Cross section mm^2
keine				
	600 V	8 A	- 16	-

QPD W 2PE1,5 4-9 M20 FC BK - Panel feed-through



1414686

<https://www.phoenixcontact.com/us/products/1414686>

Classifications

ECLASS

ECLASS-13.0	27440602
ECLASS-15.0	27440602

ETIM

ETIM 10.0	EC002566
-----------	----------

UNSPSC

UNSPSC 21.0	39121500
-------------	----------

1414686

<https://www.phoenixcontact.com/us/products/1414686>

Environmental product compliance

EU RoHS

Fulfills EU RoHS substance requirements	Yes, No exemptions
---	--------------------

China RoHS

Environment friendly use period (EFUP)	EFUP-E
	No hazardous substances above the limits

EU REACH SVHC

REACH candidate substance (CAS No.)	No substance above 0.1 wt%
-------------------------------------	----------------------------

EF3.1 Climate Change

CO2e kg	0.27 kg CO2e
---------	--------------

Phoenix Contact 2026 © - all rights reserved
<https://www.phoenixcontact.com>

Phoenix Contact USA
586 Fulling Mill Road
Middletown, PA 17057, United States
(+717) 944-1300
info@phoenixcon.com