

# NBC-R4AC/12,0-93E/R4AC - Network cable



1412088

<https://www.phoenixcontact.com/us/products/1412088>

Please be informed that the data shown in this PDF document is generated from our online catalog. Please find the complete data in the user documentation. Our general terms of use for downloads are valid.



Assembled Ethernet cable, CAT5e, shielded, 2-pair, 26\* AWG stranded (7-wire), RAL 5021 (water blue), RJ45 plug/IP20 to RJ45 plug/IP20, line, length: 12 m

## Your advantages

- Perfect for industrial applications
- Perfect for office, building, and protected industrial applications (e.g., in control cabinets)
- Compact angle

## Commercial data

|                                      |                                |
|--------------------------------------|--------------------------------|
| Item number                          | 1412088                        |
| Packing unit                         | 1 pc                           |
| Minimum order quantity               | 50 pc                          |
| Note                                 | Made to order (non-returnable) |
| Product key                          | ABNABD                         |
| GTIN                                 | 4046356948906                  |
| Weight per piece (including packing) | 518.08 g                       |
| Weight per piece (excluding packing) | 518.08 g                       |
| Country of origin                    | PL                             |

# NBC-R4AC/12,0-93E/R4AC - Network cable



1412088

<https://www.phoenixcontact.com/us/products/1412088>

## Technical data

### Product properties

|                     |                          |
|---------------------|--------------------------|
| Product type        | Data cable preassembled  |
| Product family      | RJ45 INDUSTRIAL IE4 CAT5 |
| Number of positions | 4                        |
| Shielded            | yes                      |

### Interfaces

|                      |  |
|----------------------|--|
| Signal type/category | Ethernet CAT5 (IEC 11801:2002), 100 Mbps |
|                      | Ethernet CAT5 (TIA 568B:2001), 100 Mbps  |

### Electrical properties

|   |                       |
|---|-----------------------|
| Rated voltage (III/3)                   | 72 V (DC)             |
| Nominal voltage $U_N$                   | 48 V                  |
| Nominal current $I_N$                   | 1 A                   |
| Transmission medium                     | Copper                |
| Transmission speed                      | 100 Mbps              |
| Transmission characteristics (category) | CAT5 (IEC 11801:2002) |
| Transmission speed                      | 100 Mbps              |

### Material specifications

|                        |     |
|------------------------|-----|
| Outer sheath, material | PUR |
|------------------------|-----|

### Dimensions

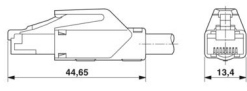
|                     |  |
|---------------------|--|
| Dimensional drawing |  |
| Width               | 13.4 mm  |
| Height              | 12.9 mm  |
| Length              | 44.7 mm  |

### Connector

#### Connection 1

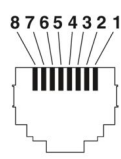
|                     |   |
|---------------------|---|
| Dimensional drawing |  |
|---------------------|---|

# NBC-R4AC/12,0-93E/R4AC - Network cable



1412088

<https://www.phoenixcontact.com/us/products/1412088>

|  |  |
|--|--|
|  | Connector pin assignment plug RJ45       |
| Type                                   | RJ45 Plug, straight, 4-position          |
| Number of positions                    | 4  |
| Signal type/category                   | Ethernet CAT5 (IEC 11801:2002), 100 Mbps |
| Insertion/withdrawal cycles            | ≥ 750                                    |
| Insertion force                        | 30 N (per signal contact)                |
| Withdrawal force                       | 50 N (per signal contact)                |
| Degree of pollution                    | 2  |
| Material Contact                       | CuSn                                     |
| Material Contact surface               | Ni/Au                                    |
| Material Contact carrier               | PC                                       |
| Material Housing                       | PA                                       |
| Color (Housing)                        | gray                                     |
| Flammability rating according to UL 94 | V2                                       |
| Degree of protection                   | IP20                                     |
| Ambient temperature (operation)        | -40 °C ... 60 °C                         |

## Connection 2

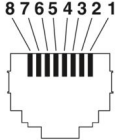
|  |  |
|--|--|
| Dimensional drawing                    |  <p>8 7 6 5 4 3 2 1</p> |
|  | Connector pin assignment plug RJ45   |
| Type                                   | RJ45 Plug, straight, 4-position  |
| Number of positions                    | 4  |
| Signal type/category                   | Ethernet CAT5 (IEC 11801:2002), 100 Mbps   |
| Insertion/withdrawal cycles            | ≥ 750  |
| Insertion force                        | 30 N (per signal contact)  |
| Withdrawal force                       | 50 N (per signal contact)  |
| Degree of pollution                    | 2  |
| Material Contact                       | CuSn   |
| Material Contact surface               | Ni/Au  |
| Material Contact carrier               | PC   |
| Material Housing                       | PA   |
| Color (Housing)                        | gray   |
| Flammability rating according to UL 94 | V2   |
| Degree of protection                   | IP20   |
| Ambient temperature (operation)        | -40 °C ... 60 °C   |

# NBC-R4AC/12,0-93E/R4AC - Network cable



1412088

<https://www.phoenixcontact.com/us/products/1412088>

## Cable/line

|   |  |
|---|--|
| Cable length                                  | 12.00 m  |
| Ethernet flexible CAT5, 2-pair [93E]          |  |
| Dimensional drawing                           |                                        |
| UL AWM Style                                  | 21238 (80 °C / 600 V)  |
| Number of positions                           | 4  |
| Shielded                                      | yes  |
| Cable type                                    | Ethernet flexible CAT5, 2-pair [93E]   |
| Conductor structure                           | 2x2xAWG26/7, SF/UTP  |
| AWG signal line                               | 26   |
| Conductor cross-section                       | 2x 2x 0.14 mm <sup>2</sup>   |
| Wire diameter incl. insulation                | 0.95 mm ±0.05 mm   |
| External cable diameter                       | 6.40 mm ±0.2 mm  |
| Outer sheath, material                        | PUR  |
| External sheath, color                        | water blue RAL 5021  |
| Conductor material                            | Bare Cu litz wires   |
| Material wire insulation                      | Foamed PE  |
| Single wire, color                            | white/orange-orange, white/green-green   |
| Twisted pairs                                 | 2 cores to the pair  |
| Overall twist                                 | Two pairs with two fillers to the core   |
| Optical shield covering                       | 70 %   |
| Insulation resistance                         | ≥ 5 GΩ*km  |
| Loop resistance                               | ≤ 280.00 Ω/km  |
| Wave impedance                                | 100 Ω ±5 Ω (at 100 MHz)  |
| Nominal voltage, cable                        | ≤ 100 V  |
| Test voltage Core/Core                        | 2000 V (50 Hz, 1 min.)   |
| Test voltage Core/Shield                      | 2000.00 V (50 Hz, 1 min.)  |
| Minimum bending radius, fixed installation    | 4 x D  |
| Minimum bending radius, flexible installation | 8 x D  |
| Smallest bending radius, fixed installation   | 26 mm  |
| Smallest bending radius, movable installation | 51 mm  |
| Halogen-free                                  | according to IEC 60754-1   |
| Flame resistance                              | according to IEC 60332-1-2<br>in accordance with UN ECE-R 118.03<br>UL 1581, Section 1060 and UL 2556, Section 9.3 (FT1) |

# NBC-R4AC/12,0-93E/R4AC - Network cable



1412088

<https://www.phoenixcontact.com/us/products/1412088>

|                                 |  |
|---------------------------------|--|
|                                 | UL 1581, Section 1100 and UL 2556, Section 9.1 (HFT/FT2) |
| Resistance to oil               | in accordance with IEC 60811-404                         |
| Ambient temperature (operation) | -40 °C ... 80 °C (cable, fixed installation)             |
|                                 | -30 °C ... 70 °C (Cable, flexible installation)          |

# NBC-R4AC/12,0-93E/R4AC - Network cable



1412088

<https://www.phoenixcontact.com/us/products/1412088>

## Drawings

Dimensional drawing

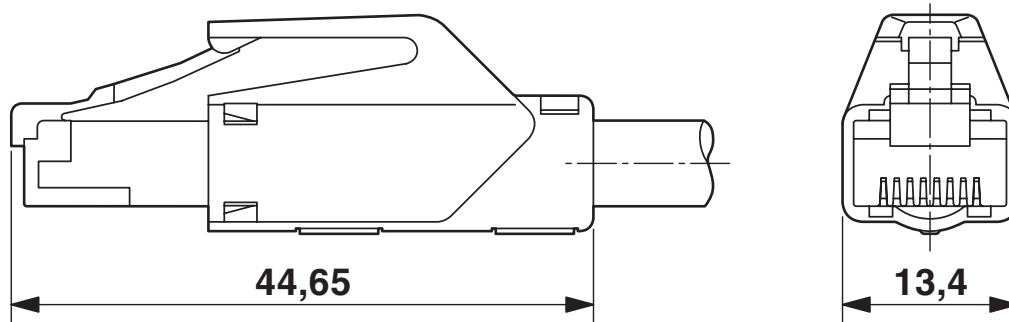

RJ45 connector, IP20

1412088

<https://www.phoenixcontact.com/us/products/1412088>

Schematic diagram



Connector pin assignment plug RJ45

Circuit diagram

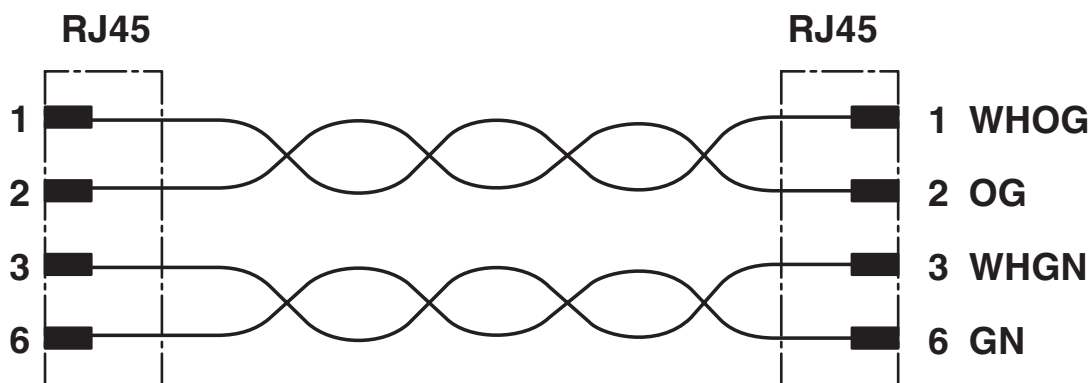

Contact assignment of RJ45 plugs

# NBC-R4AC/12,0-93E/R4AC - Network cable



1412088

<https://www.phoenixcontact.com/us/products/1412088>

## Approvals

To download certificates, visit the product detail page: <https://www.phoenixcontact.com/us/products/1412088>



**EAC**

Approval ID: 19060508

# NBC-R4AC/12,0-93E/R4AC - Network cable



1412088

<https://www.phoenixcontact.com/us/products/1412088>

## Classifications

### ECLASS

|             |          |
|-------------|----------|
| ECLASS-13.0 | 27060307 |
| ECLASS-15.0 | 27060307 |

### UNSPSC

|             |          |
|-------------|----------|
| UNSPSC 21.0 | 26121600 |
|-------------|----------|

# NBC-R4AC/12,0-93E/R4AC - Network cable



1412088

<https://www.phoenixcontact.com/us/products/1412088>

## Environmental product compliance

### EU RoHS

|   |                    |
|---|--------------------|
| Fulfills EU RoHS substance requirements | Yes, No exemptions |
|---|--------------------|

### China RoHS

|  |  |
|--|--|
| Environment friendly use period (EFUP) | EFUP-E                                   |
|  | No hazardous substances above the limits |

### EU REACH SVHC

|                                     |                            |
|-------------------------------------|----------------------------|
| REACH candidate substance (CAS No.) | No substance above 0.1 wt% |
|-------------------------------------|----------------------------|

### EF3.1 Climate Change

|         |                |
|---------|----------------|
| CO2e kg | 19.139 kg CO2e |
|---------|----------------|

Phoenix Contact 2026 © - all rights reserved  
<https://www.phoenixcontact.com>

Phoenix Contact USA  
586 Fulling Mill Road  
Middletown, PA 17057, United States  
(+717) 944-1300  
[info@phoenixcon.com](mailto:info@phoenixcon.com)