

# QPD H 4PE6,0 4X12-20 GY - H distributor



1411429

<https://www.phoenixcontact.com/us/products/1411429>

Please be informed that the data shown in this PDF document is generated from our online catalog. Please find the complete data in the user documentation. Our general terms of use for downloads are valid.



QUICKON H-distributor, gray, 4+PE-pos., 2.5 mm<sup>2</sup> ... 6.0 mm<sup>2</sup>/690 V/40 A, for cable diameter of 12 mm ... 20 mm, with a sealing bolt.

## Your advantages

- Innovative and time saving - QUICKON fast connection for time saving of up to 80 % for on-site connection
- Robust throughout: housing with IP68/IP69K and IK07 protection for a wide range of applications
- Safer connection with mechanical coding to protect against mismatching, and touch-proof protection in accordance with DIN EN 0105
- Flexible and compact - by connecting connections internally, H and T-distributors can be used to branch master cables or they can be used as star distributors

## Commercial data

Item number	1411429
Packing unit	1 pc
Minimum order quantity	1 pc
Product key	AF6DCC
GTIN	4046356932295
Weight per piece (including packing)	22.22 g
Weight per piece (excluding packing)	22.22 g
Country of origin	PL

1411429

<https://www.phoenixcontact.com/us/products/1411429>

## Technical data

### Mounting

Mounting type	direct screw connection
---------------	-------------------------

### Product properties

Product type	Power distributor
Product family	QPD
Type	H-distributor
Number of positions	5
Connection profile	4+PE
Position marking	1, 2, L, N, PE
Number of connections	5
No. of cable outlets	4
Coding	Coding profile

### Insulation characteristics

Overvoltage category	III
Degree of pollution	3

### Connection data

#### Connection technology

Connection method	IDC connection
Frequency of connections between conductors of the same cross section	max. 10

#### Conductor connection

Conductor cross-section flexibel	2.5 mm <sup>2</sup> ... 6 mm <sup>2</sup>
Conductor cross-section solid	2.5 mm <sup>2</sup> ... 6 mm <sup>2</sup>
Connection cross section AWG	14 ... 10
Tightening torque Union nut	15 Nm
Wrench size Union nut	30 mm

### Dimensions

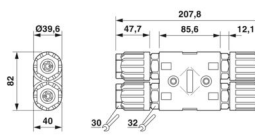
Dimensional drawing	
Width	82 mm
Height	40 mm
Length	207.8 mm
Wrench size	30 mm
Wrench size for mounting	30 mm

1411429

<https://www.phoenixcontact.com/us/products/1411429>

## Electrical properties

Rated surge voltage (II/2)	8 kV
Rated surge voltage (III/2)	8 kV
Rated surge voltage (III/3)	6 kV
Rated current	40 A
Contact resistance	< 3 mΩ
rated voltage (II/2)	1000 V
rated voltage (III/2)	1000 V
Rated voltage (III/3)	690 V
Nominal voltage $U_N$	690 V
Nominal current $I_N$	40 A

## Material specifications

Material Housing	PA
Material Contact	Cu
Material Contact surface	silver-plated
Flammability rating according to UL 94	V0
Material wire insulation	PVC/PE/TPE/rubber

## Cable/line

Structure of individual litz in acc. with VDE 0295 / smallest wire diameter	VDE 0295 class 1 to 6/min. 0.15 mm
External cable diameter	12 mm ... 20 mm
Wire diameter including insulation	2.95 mm ... 5 mm
Position marking	1, 2, L, N, PE
Material wire insulation	PVC/PE/TPE/rubber

## Environmental and real-life conditions

### Ambient conditions

Degree of protection	IP66
	IP68 (2 m / 24 h)
	IP69K
Impact strength	IK07
Ambient temperature (operation)	-40 °C ... 100 °C
Temperature when conductor connected	-5 °C ... 50 °C
Ambient temperature (storage/transport)	-40 °C ... 100 °C

Drawings

Dimensional drawing

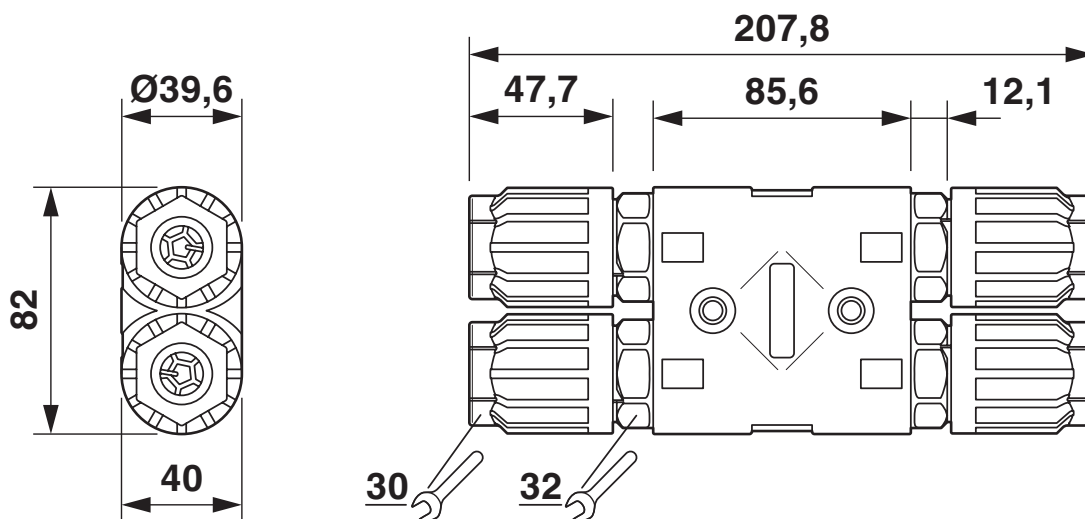

Dimensional drawing

Diagram

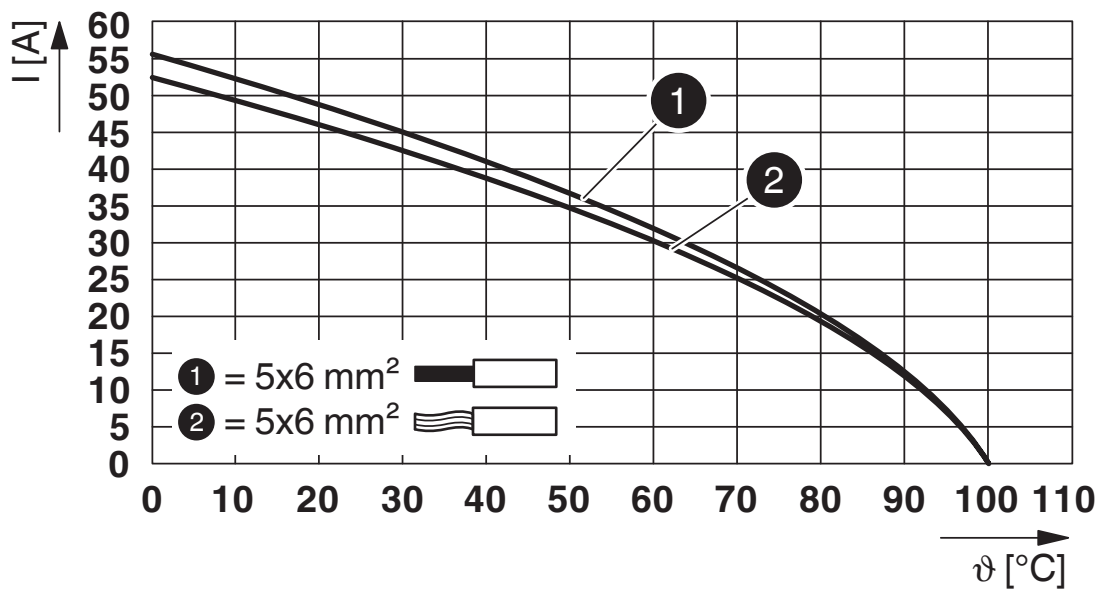

Derating diagram

# QPD H 4PE6,0 4X12-20 GY - H distributor

1411429

<https://www.phoenixcontact.com/us/products/1411429>



Circuit diagram



# QPD H 4PE6,0 4X12-20 GY - H distributor



1411429

<https://www.phoenixcontact.com/us/products/1411429>

## Classifications

### ECLASS

ECLASS-13.0	27440603
ECLASS-15.0	27440603

### ETIM

ETIM 9.0	EC002567
----------	----------

1411429

<https://www.phoenixcontact.com/us/products/1411429>

## Environmental product compliance

### China RoHS

Environment friendly use period (EFUP)	EFUP-50
	An article-related China RoHS declaration table can be found in the download area for the respective article under "Manufacturer declaration". For all articles with EFUP-E, no China RoHS declaration table issued and required.

### EU REACH SVHC

REACH candidate substance (CAS No.)	No substance above 0.1 wt%
-------------------------------------	----------------------------

Phoenix Contact 2026 © - all rights reserved  
<https://www.phoenixcontact.com>

Phoenix Contact USA  
586 Fulling Mill Road  
Middletown, PA 17057, United States  
(+717) 944-1300  
[info@phoenixcon.com](mailto:info@phoenixcon.com)