

# QPD W 4PE2,5 9-16 M25 1,0 EX - Panel feed-through



1411391

<https://www.phoenixcontact.com/us/products/1411391>

Please be informed that the data shown in this PDF document is generated from our online catalog. Please find the complete data in the user documentation. Our general terms of use for downloads are valid.



QUICKON panel feed-through for the hazardous area, 4+PE-pos., 1.0 mm<sup>2</sup>... 2.5 mm<sup>2</sup>/with QUICKON nut, black, for cable diameter 9 mm ... 16 mm, M25 connection thread with 5 welded-on 2.5 mm<sup>2</sup> cable wires, 1.0 m long, cut off straight at the end.

## Your advantages

- Innovative and time saving - QUICKON fast connection for time saving of up to 80 % for on-site connection
- Robust throughout: housing with IP68/IP69K and IK07 protection for a wide range of applications
- Safer connection with mechanical coding to protect against mismatching, and touch-proof protection in accordance with DIN EN 0105
- Efficient - by using panel feed-throughs, devices no longer need to be opened in order to connect cables

## Commercial data

Item number	1411391
Packing unit	1 pc
Minimum order quantity	25 pc
Product key	AF6ACB
GTIN	4046356930055
Weight per piece (including packing)	22.22 g
Weight per piece (excluding packing)	22.22 g
Country of origin	PL

1411391

<https://www.phoenixcontact.com/us/products/1411391>

## Technical data

### Product properties

Product type	Panel feed-through
Product family	QPD
Type	QPD 5x2,5
Number of positions	5
Connection profile	4+PE
Position marking	1, 2, 3, N, PE
Number of connections	10
Number of connections per position	1
Coding	coded

### Insulation characteristics

Overvoltage category	III
Degree of pollution	3

### Connection data

#### Connection technology

Connection method On the device side	Single wires
Connection method On the field side	IDC connection
Frequency of connections between conductors of the same cross section	max. 10

#### Conductor connection

Conductor cross-section flexibel	1 mm <sup>2</sup> ... 2.5 mm <sup>2</sup>
Conductor cross-section solid	1 mm <sup>2</sup> ... 2.5 mm <sup>2</sup>
Connection cross section AWG	16 ... 14
Tightening torque Union nut	10 Nm
Tightening torque Locking nut	5 Nm
Wrench size Union nut	27 mm
Wrench size Locking nut	30 mm

### Dimensions

Dimensional drawing	
Width	34.6 mm
Height	34.6 mm
Length	71.8 mm
Diameter	34.6 mm
Wrench size	27 mm

# QPD W 4PE2,5 9-16 M25 1,0 EX - Panel feed-through



1411391

<https://www.phoenixcontact.com/us/products/1411391>

Wrench size for mounting	27 mm
--------------------------	-------

## Electrical properties

Rated surge voltage (II/2)	8 kV
Rated surge voltage (III/2)	8 kV
Rated surge voltage (III/3)	6 kV
Contact resistance	< 3 mΩ
Rated voltage (III/3)	60 V
Nominal voltage $U_N$	60 V
Nominal current $I_N$	20 A

## Material specifications

Material Housing	PA
Material Contact	Cu
Material Contact surface	silver-plated
Flammability rating according to UL 94	V0
Material wire insulation	PVC/PE/TPE/rubber

## Cable/line

Cable length	1 m
Structure of individual litz in acc. with VDE 0295 / smallest wire diameter	VDE 0295 class 1 to 6/min. 0.15 mm
Wire diameter including insulation	2 mm ... 3.8 mm
Position marking	1, 2, 3, N, PE
Material wire insulation	PVC/PE/TPE/rubber

## Mounting

Mounting type	Front mounting M25
---------------	--------------------

## Environmental and real-life conditions

### Ambient conditions

Degree of protection	IP66
	IP68 (2 m / 24 h)
	IP69K
Impact strength	IK07
Ambient temperature (operation)	-40 °C ... 100 °C
Temperature when conductor connected	-5 °C ... 50 °C
Ambient temperature (storage/transport)	-40 °C ... 80 °C

# QPD W 4PE2,5 9-16 M25 1,0 EX - Panel feed-through



1411391

<https://www.phoenixcontact.com/us/products/1411391>

## Drawings

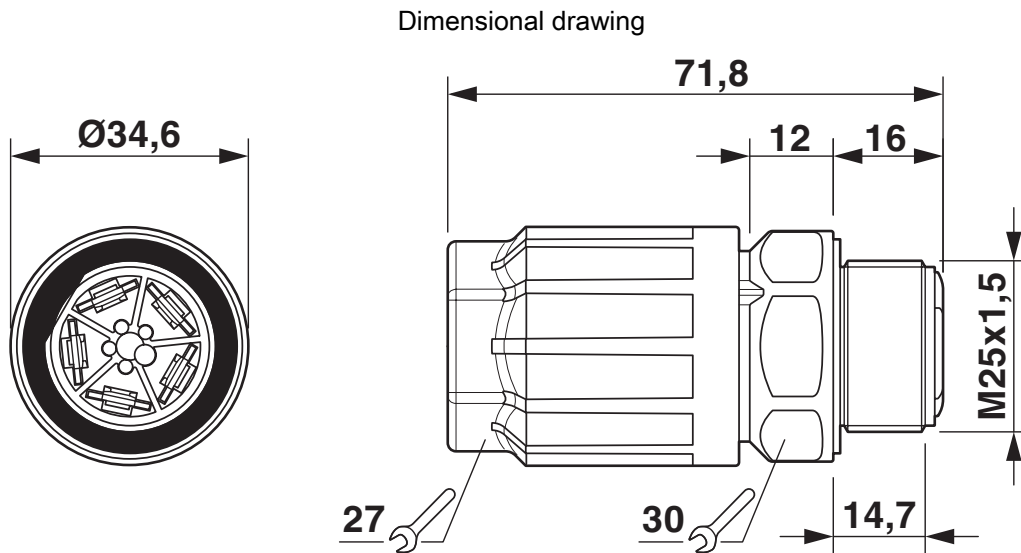

QPD W 4PE2.5 M25 dimensional drawing

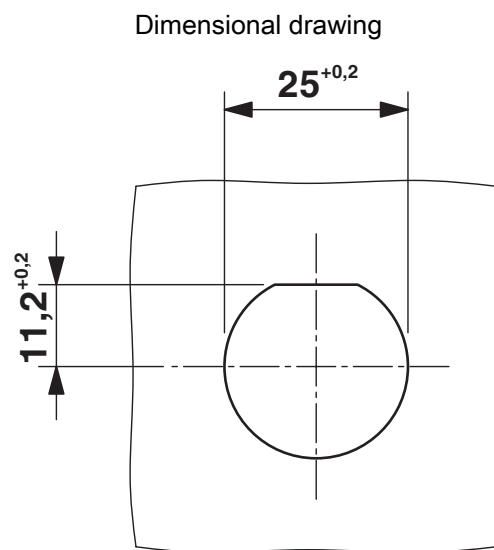

Panel cutout

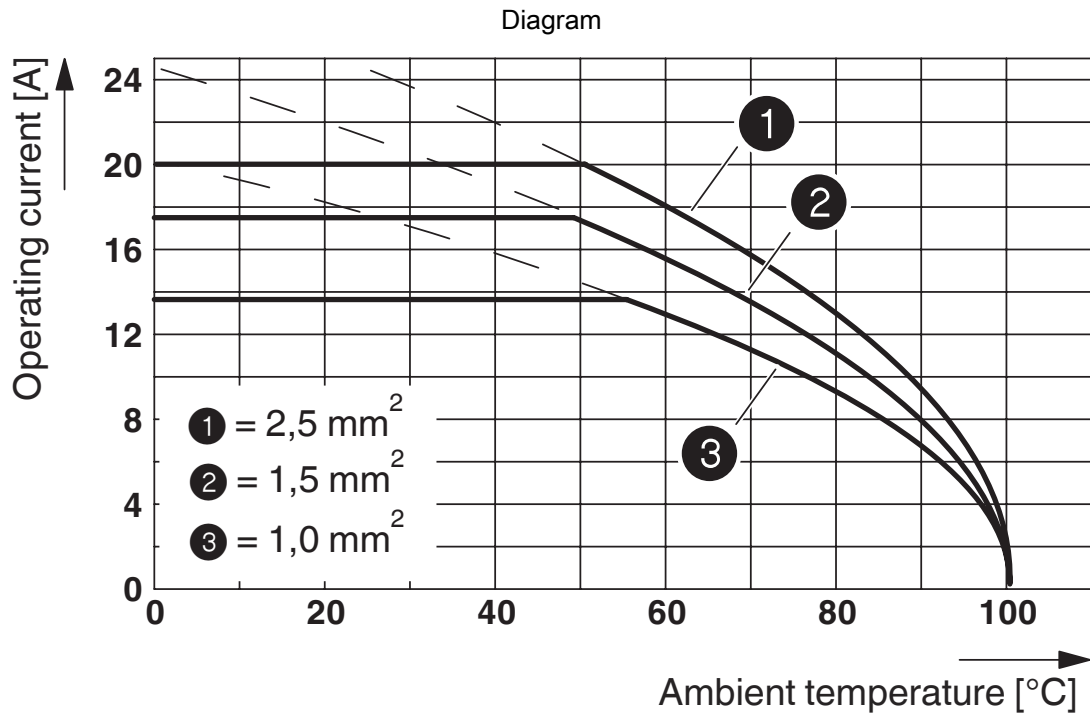

1411391

<https://www.phoenixcontact.com/us/products/1411391>

## Classifications

### ECLASS

ECLASS-13.0	27440602
ECLASS-15.0	27440602

### UNSPSC

UNSPSC 21.0	39121522
-------------	----------

1411391

<https://www.phoenixcontact.com/us/products/1411391>

## Environmental product compliance

### EU RoHS

Fulfills EU RoHS substance requirements	Yes, No exemptions
---	--------------------

### China RoHS

Environment friendly use period (EFUP)	EFUP-50
	An article-related China RoHS declaration table can be found in the download area for the respective article under "Manufacturer declaration". For all articles with EFUP-E, no China RoHS declaration table issued and required.

### EU REACH SVHC

REACH candidate substance (CAS No.)	No substance above 0.1 wt%
-------------------------------------	----------------------------

Phoenix Contact 2026 © - all rights reserved

<https://www.phoenixcontact.com>

Phoenix Contact USA  
586 Fulling Mill Road  
Middletown, PA 17057, United States  
(+717) 944-1300  
[info@phoenixcon.com](mailto:info@phoenixcon.com)