

A-INL-PG13,5-N-S - Counter nut

1411259

<https://www.phoenixcontact.com/us/products/1411259>

Please be informed that the data shown in this PDF document is generated from our online catalog. Please find the complete data in the user documentation. Our general terms of use for downloads are valid.

Counter nut, for threads Pg13.5, color: silver-colored



Commercial data

Item number	1411259
Packing unit	100 pc
Minimum order quantity	100 pc
Sales key	BF68
Product key	AF7DZX
GTIN	4046356923910
Weight per piece (including packing)	3.46 g
Weight per piece (excluding packing)	3.308 g
Customs tariff number	74198090
Country of origin	IN

A-INL-PG13,5-N-S - Counter nut

1411259

<https://www.phoenixcontact.com/us/products/1411259>

Technical data

Product properties

Product type	Flat nut
Thread type	Pg13.5

Dimensions

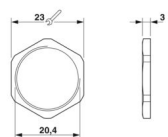
Dimensional drawing	
Length	3 mm
Diameter Connecting thread	20.4 mm
Connecting thread diameter	20.4 mm
Wrench size, counter nut	23 mm
Hexagon angular dimension	26 mm
Thread type connection side	Pg13.5

Material specifications

Material	Brass, nickel-plated
----------	----------------------

Cable/line

Halogen-free	yes
--------------	-----

Environmental and real-life conditions

Ambient conditions

Ambient temperature (operation)	-70 °C ... 220 °C
---------------------------------	-------------------

A-INL-PG13,5-N-S - Counter nut

1411259

<https://www.phoenixcontact.com/us/products/1411259>



Drawings

Dimensional drawing

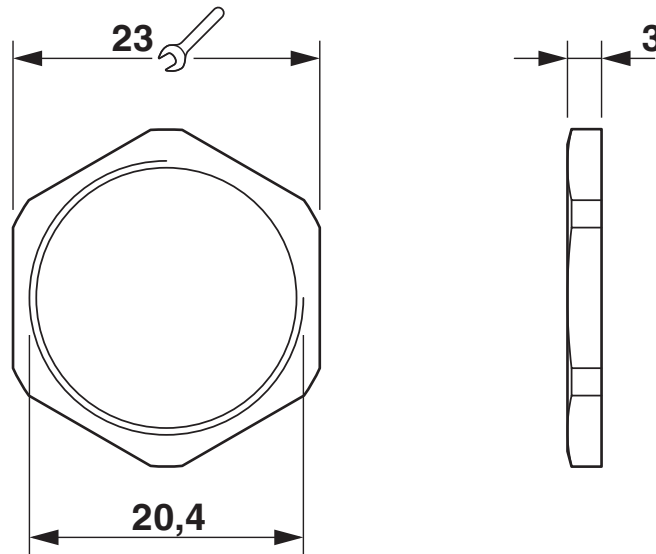

A-INL-PG13,5-N-S - Counter nut



1411259

<https://www.phoenixcontact.com/us/products/1411259>

Classifications

ECLASS

ECLASS-13.0	27140807
ECLASS-15.0	27140807

ETIM

ETIM 10.0	EC003608
-----------	----------

UNSPSC

UNSPSC 21.0	31161700
-------------	----------

A-INL-PG13,5-N-S - Counter nut



1411259

<https://www.phoenixcontact.com/us/products/1411259>

Environmental product compliance

EU RoHS

Fulfills EU RoHS substance requirements	Yes
Exemption	6(c)

China RoHS

Environment friendly use period (EFUP)	EFUP-50
	An article-related China RoHS declaration table can be found in the download area for the respective article under "Manufacturer declaration". For all articles with EFUP-E, no China RoHS declaration table issued and required.

EU REACH SVHC

REACH candidate substance (CAS No.)	Lead(CAS: 7439-92-1)
SCIP	4b8ae253-e97e-443c-83e0-47a6b97a8b98

Phoenix Contact 2026 © - all rights reserved

<https://www.phoenixcontact.com>

Phoenix Contact USA
586 Fulling Mill Road
Middletown, PA 17057, United States
(+717) 944-1300
info@phoenixcon.com