

G-EDSWU-M63-L66L-STES-S - Cable gland



1411103

<https://www.phoenixcontact.com/us/products/1411103>

Please be informed that the data shown in this PDF document is generated from our online catalog. Please find the complete data in the user documentation. Our general terms of use for downloads are valid.



Cable gland, material for screw connection: Stainless steel 316L, application: Ex, external cable diameter 54.6 mm ... 65.9 mm, shielding: yes, connecting thread: M63 x 1.5, color: silver-colored

Product description

Cable gland, for armored cables (SWA / AWA / PWA / STA / SWB / ASA / CY / SY)

Your advantages

- If space is restricted at the fixing location of the screw connection, the armor can be attached at a location where there is more room to move. Final assembly can then be easily completed in the restricted space conditions at the fixing location of the screw connection.
- Armor connected via PE cone
- Weatherproof sealing material

Commercial data

Item number	1411103
Packing unit	1 pc
Minimum order quantity	1 pc
Sales key	BF68
Product key	AF7DDX
GTIN	4046356922180
Weight per piece (including packing)	22.22 g
Weight per piece (excluding packing)	22.22 g
Customs tariff number	73269098
Country of origin	GB

Technical data

Notes

Notes on the product family	with seal for conductor outer and inner jacket
-----------------------------	------------------------------------------------

Mounting

Assembly note	With integrated grounding cones, sealed to IP66/IP67/IP68 thanks to the use of the A-SEW-63-P-W flat gasket (item 1411288)
	If space is restricted at the fixing location of the screw connection, the armor can be attached at a location where there is more room to move. Final assembly can then be easily completed in the restricted space conditions at the fixing location of the screw connection.

Product properties

Product type	Cable screw gland
Application	Ex
No. of conductors	1
Manufacturer	CMP
Manufacturer Designation	T3CDS1RA, thread size 63
Shielded	yes
Execution of the strain relief	D

Ex data

Cable types that can be used	Depending on the material of the housing wall (SWA/AWA/PWA/STA/ASA/CY/SY/SWB)
Suited for EX-applications	yes

Characteristics

Category of shock impact	8
Cable diameter without cable sheath	47.2 mm ... 56 mm
Cable diameter without armor	47.2 mm ... 56 mm (Filler beneath the armor)
Design, Strain relief	D

Dimensions

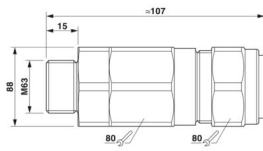
Dimensional drawing	
Length	107 mm
Length of the connecting thread	15 mm
Wrench size, union nut	80 mm
Wrench size, support	80 mm

G-EDSWU-M63-L66L-STES-S - Cable gland



1411103

<https://www.phoenixcontact.com/us/products/1411103>

Hexagon angular dimension	88 mm
Thread type connection side	M63 x 1.5
Thread pitch	1.5 mm
Armor thickness	2 mm ... 2.5 mm (Stepped cone side (SWA/...))
	0 mm ... 1.5 mm (Grooved cone side (STA/...))

Material specifications

Color	Steel/stainless steel color
Seal material Cable seal	EPDM
Material for screw connection	Stainless steel 316L

Cable/line

External cable diameter	54.6 mm ... 65.9 mm
-------------------------	---------------------

Environmental and real-life conditions

Ambient conditions

Degree of protection	IP66 (using the corresponding A-SEW-...P-W flat gasket)
	IP67 (using the corresponding A-SEW-...P-W flat gasket)
	IP68 (using the corresponding A-SEW-...P-W flat gasket)
Ambient temperature (operation)	-60 °C ... 130 °C (static)

Approvals

ATEX	Sira 13ATEX1073X
	Sira 13ATEX4079X
	Ex II 2G, II 1D, Ex d IIC Gb, Ex e IIC Gb, Ex ta IIIC Da, Ex II 3G Ex nR IIC Gc, Ex I M2, Ex d I Mb, Ex e I Mb
IECEX	IECEX SIR 13.0028X
	Ex d IIC Gb, Ex e IIC Gb, Ex nR IIC Gc, Ex ta IIIC Da, Ex d I Mb, Ex e I Mb

Standards and regulations

EN Ex

Standards/specifications	EN 60079-0, -1, -7, -15, -31
--------------------------	------------------------------

IEC Ex

Standards/specifications	IEC 60079-0, -1, -7, -15, -31
--------------------------	-------------------------------

Cable glands

Standards/specifications	EN 50262
--------------------------	----------

Cable glands

Standards/specifications	IEC 62444
--------------------------	-----------

IEC Ex

Standards/specifications	IEC 61241-0:2004
--------------------------	------------------

G-EDSWU-M63-L66L-STES-S - Cable gland



1411103

<https://www.phoenixcontact.com/us/products/1411103>

Drawings

Dimensional drawing

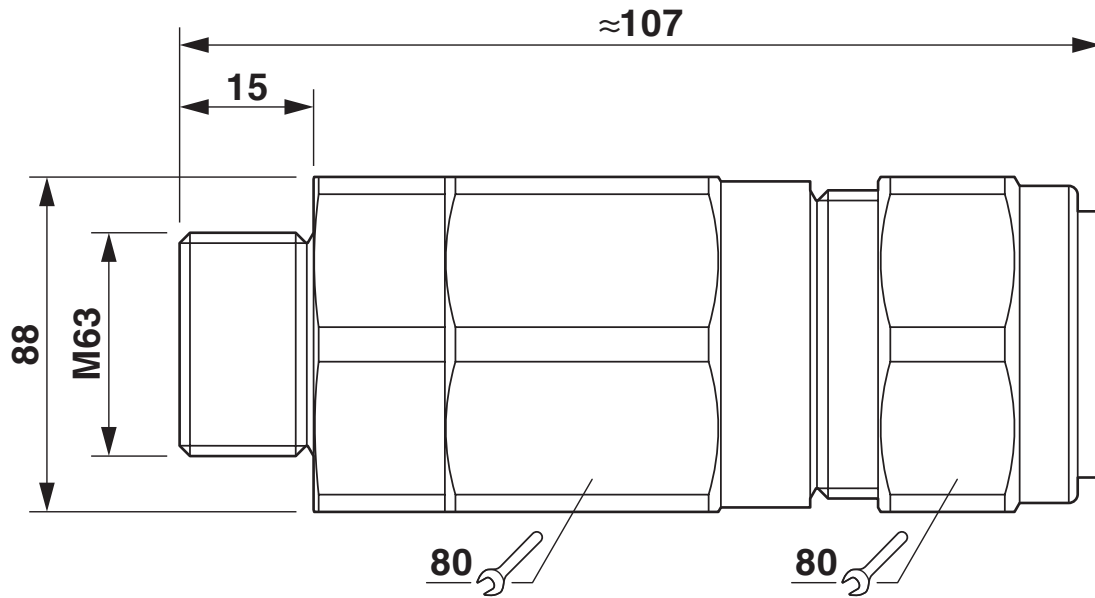

Dimensional drawing

G-EDSWU-M63-L66L-STES-S - Cable gland



1411103

<https://www.phoenixcontact.com/us/products/1411103>

Classifications

ECLASS

ECLASS-13.0	27140802
ECLASS-15.0	27140802

ETIM

ETIM 9.0	EC000441
----------	----------

UNSPSC

UNSPSC 21.0	39121300
-------------	----------

1411103

<https://www.phoenixcontact.com/us/products/1411103>

Environmental product compliance

EU RoHS

Fulfills EU RoHS substance requirements	Yes
Exemption	6(c)

China RoHS

Environment friendly use period (EFUP)	EFUP-50
	An article-related China RoHS declaration table can be found in the download area for the respective article under "Manufacturer declaration". For all articles with EFUP-E, no China RoHS declaration table issued and required.

EU REACH SVHC

REACH candidate substance (CAS No.)	Lead(CAS: 7439-92-1)
SCIP	33ade9bc-94ff-40b7-bf04-7a13a42e15a6

Phoenix Contact 2026 © - all rights reserved

<https://www.phoenixcontact.com>

Phoenix Contact USA
586 Fulling Mill Road
Middletown, PA 17057, United States
(+717) 944-1300
info@phoenixcon.com