

EV-T2M3SE24-3AC32A-0,5M6,0E11 - Infrastructure charging socket



1409681

<https://www.phoenixcontact.com/us/products/1409681>

Please be informed that the data shown in this PDF document is generated from our online catalog. Please find the complete data in the user documentation. Our general terms of use for downloads are valid.



CHARX connect, Type 2, Infrastructure charging socket, 32 A , 480 V AC, Gen 1, Single-core wires connected at one end, length: 0.5 m, locking actuator: 24 V, 4-pos., Rear panel mounting, additional splash protection at the rear with single-core wire seals, for charging electric vehicles (EV) with alternating current (AC), PHOENIX CONTACT logo, IEC 62196-2

Product description

Infrastructure charging socket for charging electric vehicles (EV) with alternating current (AC), compatible with type 2 Infrastructure Plugs, for installation at charging stations for E-Mobility (EVSE)

Your advantages

- Complete product range
- Uniform, space-saving installation space
- Available with your logo on request - for consistent branding of your charging station
- Integrated interlock during charging
- Manual emergency release of the locking actuator
- Developed and produced in accordance with the IATF 16949 automotive standard and ISO 9001

Commercial data

Item number	1409681
Packing unit	1 pc
Note	Made to order (non-returnable)
Sales key	EM01
Product key	XWBADC
GTIN	4046356872645
Weight per piece (including packing)	584.7 g
Weight per piece (excluding packing)	584.7 g
Customs tariff number	85444290
Country of origin	DE

EV-T2M3SE24-3AC32A-0,5M6,0E11 - Infrastructure charging socket



1409681

<https://www.phoenixcontact.com/us/products/1409681>

Technical data

Product properties

Product type	Infrastructure charging socket
Product family	CHARX connect
Type	Gen 1
Design	additional splash protection at the rear with single-core wire seals
Charging standard	Type 2
Charging mode	Mode 3, Case B
Affixed logo	PHOENIX CONTACT logo
Customer variations	On request

Electrical properties

Type of signal transmission	Pulse width modulation
Note on the connection method	Crimp connection, cannot be disconnected

Charging power and current (AC charging, 3-phase)

Type of charging current	AC 3-phase
Charging current	32 A AC (3-phase)
Charging power	26.6 kW (3-phase)
Charging power rating	22 kW (32 A, 3-phase)
Rated voltage	480 V

Pin assignment (Power contacts)

Number	5 (L1, L2, L3, N, PE)
Rated voltage	480 V AC
Rated current	32 A

Pin assignment (Signal contacts)

Number	2 (CP, PP)
Rated voltage	30 V AC
Rated current	2 A

Locking actuator

Locking actuator	24 V, 4-pos.
	Top center position
Possible power supply range at the motor	22 V ... 26 V
Maximum voltage for locking detection	30 V
Typical motor current for locking	0.05 A
Reverse current of the motor	max. 0.5 A
Max. dwell time with reverse current	1 s
Recommended adaptation time	600 ms
Pause time after entry or exit path	3 s
Service life insertion cycles	> 10000 load cycles

EV-T2M3SE24-3AC32A-0,5M6,0E11 - Infrastructure charging socket



1409681

<https://www.phoenixcontact.com/us/products/1409681>

Lock recognition	available
Mechanical emergency release	available
Ambient temperature (operation)	-30 °C ... 50 °C
Cable length	0.5 m
Cable structure	4 x 0.5 mm ²
Bending radius	min. 15 mm
External cable diameter	1.60 mm ±0.02 mm
Cable weight	7.00 kg/km
Cable resistance	≤ 37.1 Ω/m
Single wire, color	BU/RD, BU/GN, BU/YE, BU/BN

Dimensions

Infrastructure charging socket

Width	75 mm
Height	96 mm
Depth	76.2 mm

Bore dimensions

Width	60 mm
Height	60 mm

Cable/line

Cable length	0.5 m (AC cables)
	0.5 m (Locking actuator cables)
Cable type	Single-core wires connected at one end
Cable structure	5x 6.0 mm ² + 2x 0.5 mm ²

Mechanical properties

Mechanical data

Insertion/withdrawal cycles	> 10000
Insertion force	< 100 N
Withdrawal force	< 100 N

Environmental and real-life conditions

Ambient conditions

Ambient temperature (operation)	-30 °C ... 50 °C
Ambient temperature (storage/transport)	-40 °C ... 80 °C
Altitude	5000 m (above sea level)

Standards and regulations

Standards

Standards/regulations	IEC 62196-2
-----------------------	-------------

EV-T2M3SE24-3AC32A-0,5M6,0E11 - Infrastructure charging socket



1409681

<https://www.phoenixcontact.com/us/products/1409681>

Mounting

Mounting type Infrastructure charging socket	Rear panel mounting (0 to 90 degree frontal inclination possible)
	Front mounting (only possible when the locking actuator is removed (see EV-T2M3SE...E00 versions))
Mounting type Protective cover	rear (available separately)
Mounting hole diameter	7.00 mm (ø)

EV-T2M3SE24-3AC32A-0,5M6,0E11 - Infrastructure charging socket



1409681

<https://www.phoenixcontact.com/us/products/1409681>

Drawings

Dimensional drawing

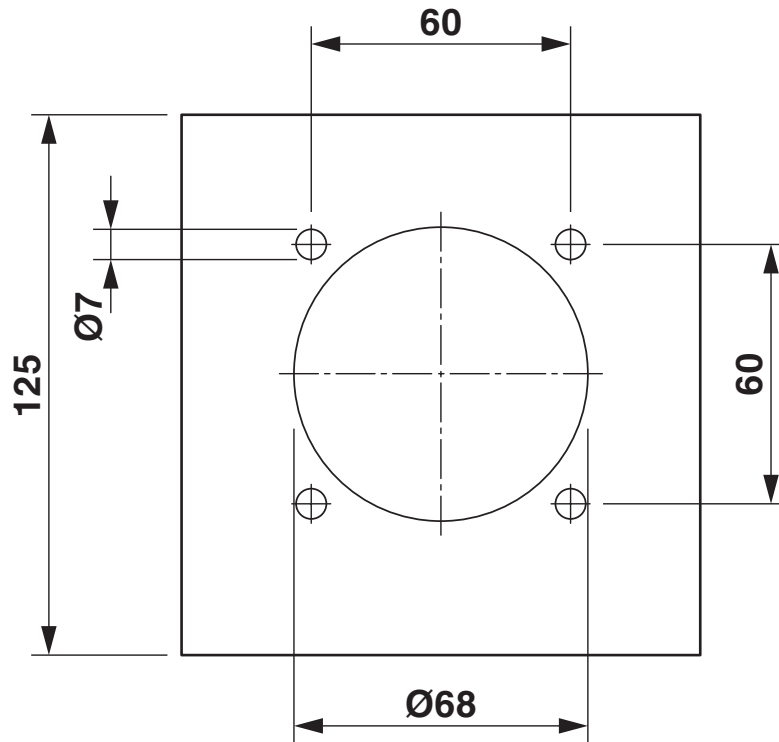

Hole image

EV-T2M3SE24-3AC32A-0,5M6,0E11 - Infrastructure charging socket

1409681

<https://www.phoenixcontact.com/us/products/1409681>

Dimensional drawing

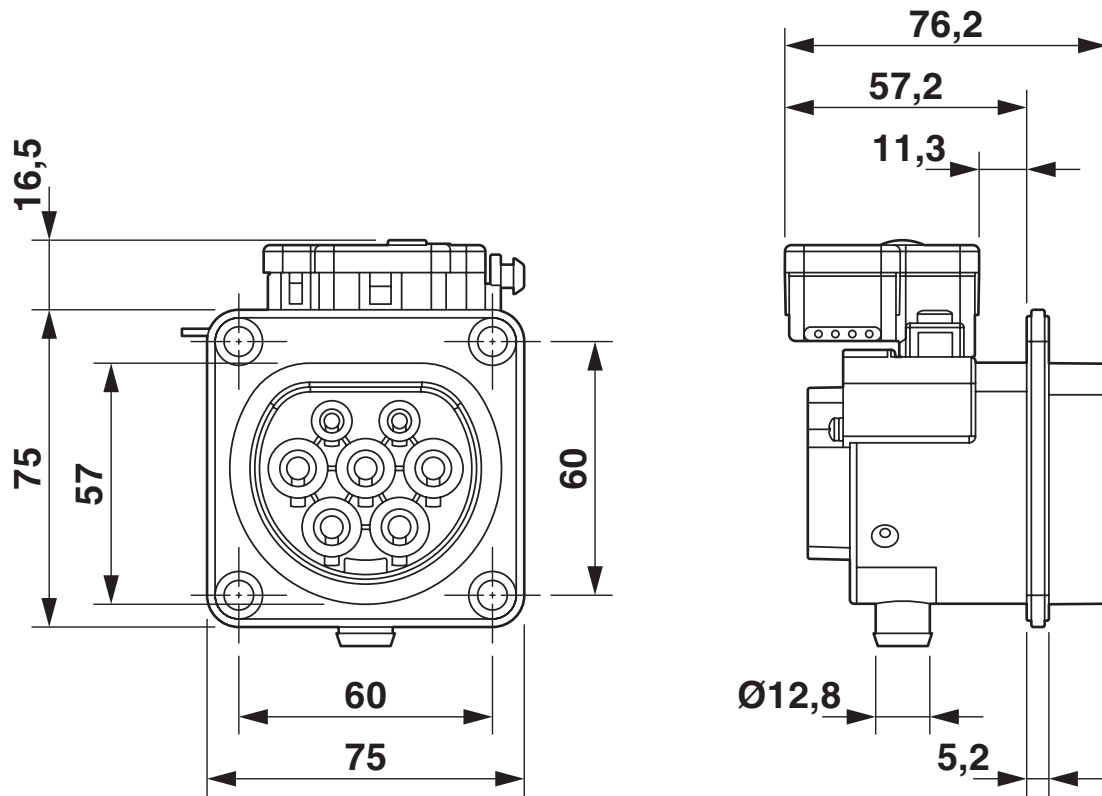

Dimensional drawing

EV-T2M3SE24-3AC32A-0,5M6,0E11 - Infrastructure charging socket

1409681

<https://www.phoenixcontact.com/us/products/1409681>

Connection diagram

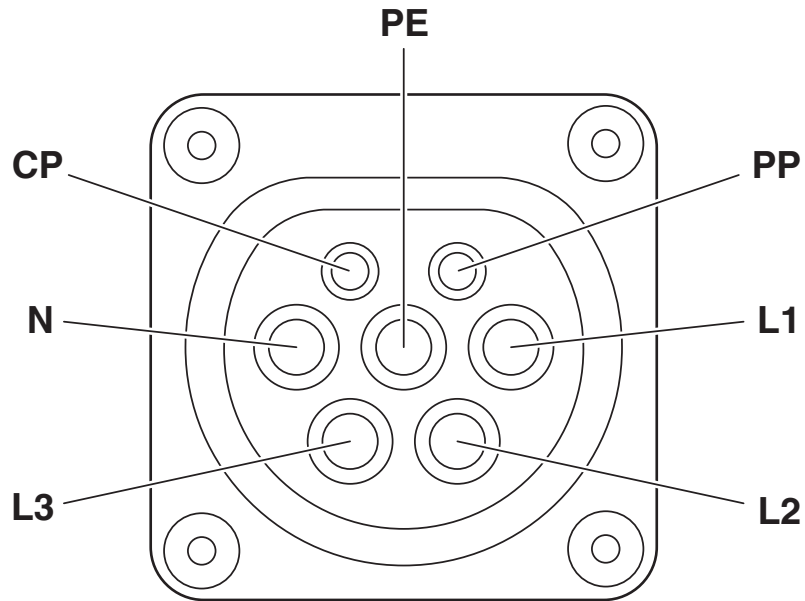

Pin assignment of infrastructure charging socket

EV-T2M3SE24-3AC32A-0,5M6,0E11 - Infrastructure charging socket

1409681

<https://www.phoenixcontact.com/us/products/1409681>

Schematic diagram

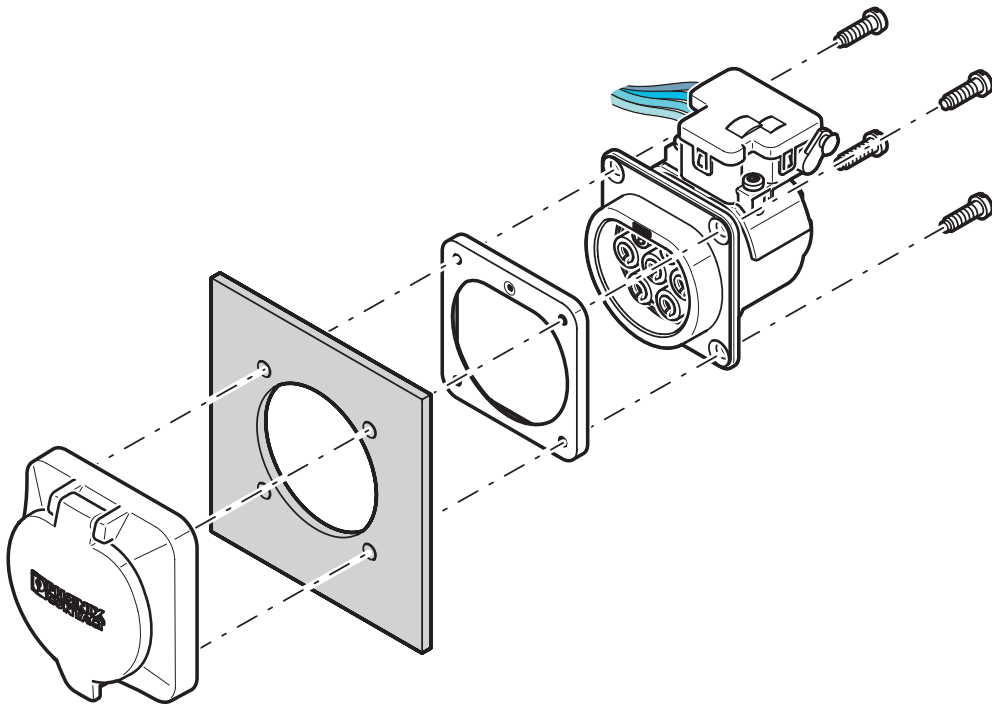

Rear mounting with rear protective cover screw connection

The screw connection for a protective cover from the accessories range (EV-T2SC) only supports rear mounting. The panel thickness must not exceed 5 mm. The sealing frame that is slid on from the rear must contact the housing panel flush with the flat side and must completely surround the infrastructure socket outlet.

EV-T2M3SE24-3AC32A-0,5M6,0E11 - Infrastructure charging socket

1409681

<https://www.phoenixcontact.com/us/products/1409681>

Schematic diagram

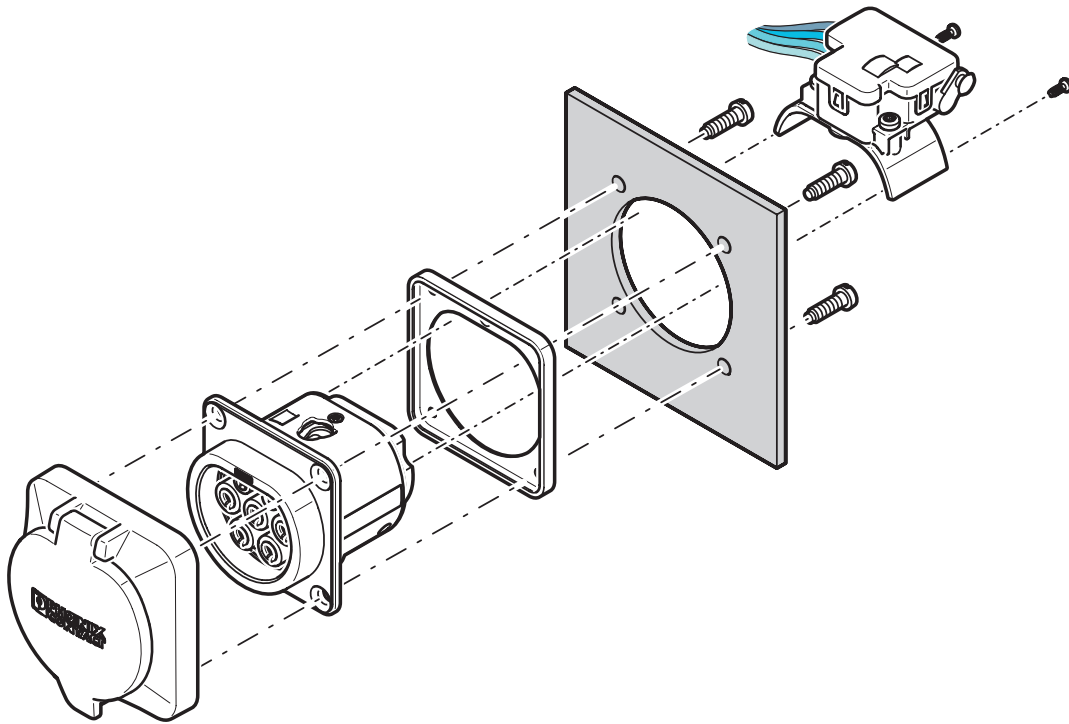

Front mounting with rear protective cover screw connection

Front mounting is only possible when the locking actuator is removed. We recommend using an infrastructure socket outlet without pre-assembled locking actuator (EV-T2M3SE-...E0..., e.g., 1621729).

The screw connection for a protective cover from the accessories range (EV-T2SC) only supports rear mounting. The panel thickness must not exceed 10 mm. The sealing frame that is slid on from the front must contact the housing panel flush with the flat side and must completely surround the infrastructure socket outlet.

EV-T2M3SE24-3AC32A-0,5M6,0E11 - Infrastructure charging socket

1409681

<https://www.phoenixcontact.com/us/products/1409681>

Schematic diagram

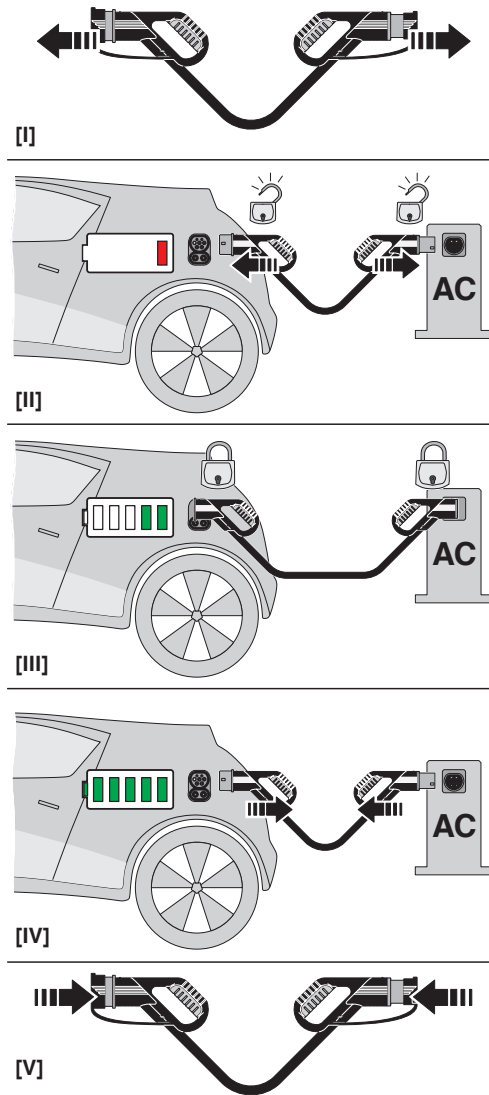

Operating instructions

EV-T2M3SE24-3AC32A-0,5M6,0E11 - Infrastructure charging socket

1409681

<https://www.phoenixcontact.com/us/products/1409681>

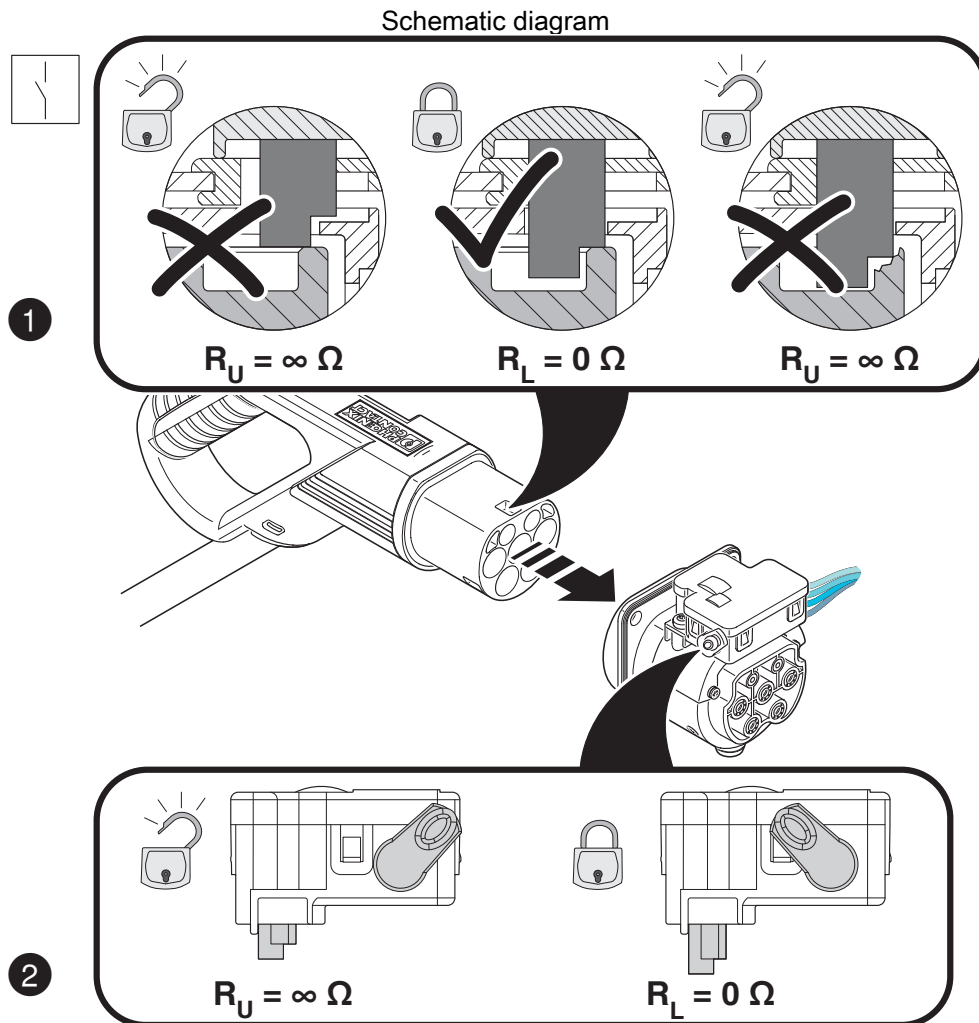

Detection of the Infrastructure Plug

Schematic diagram

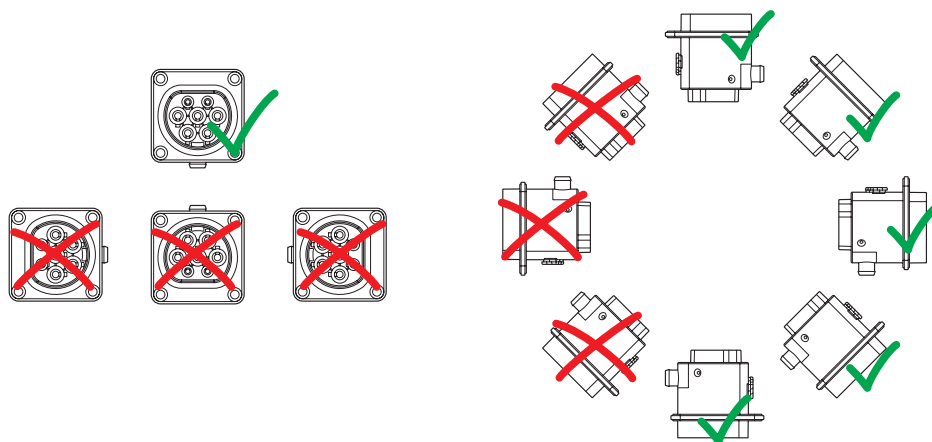

Installation positions

EV-T2M3SE24-3AC32A-0,5M6,0E11 - Infrastructure charging socket



1409681

<https://www.phoenixcontact.com/us/products/1409681>

Schematic diagram

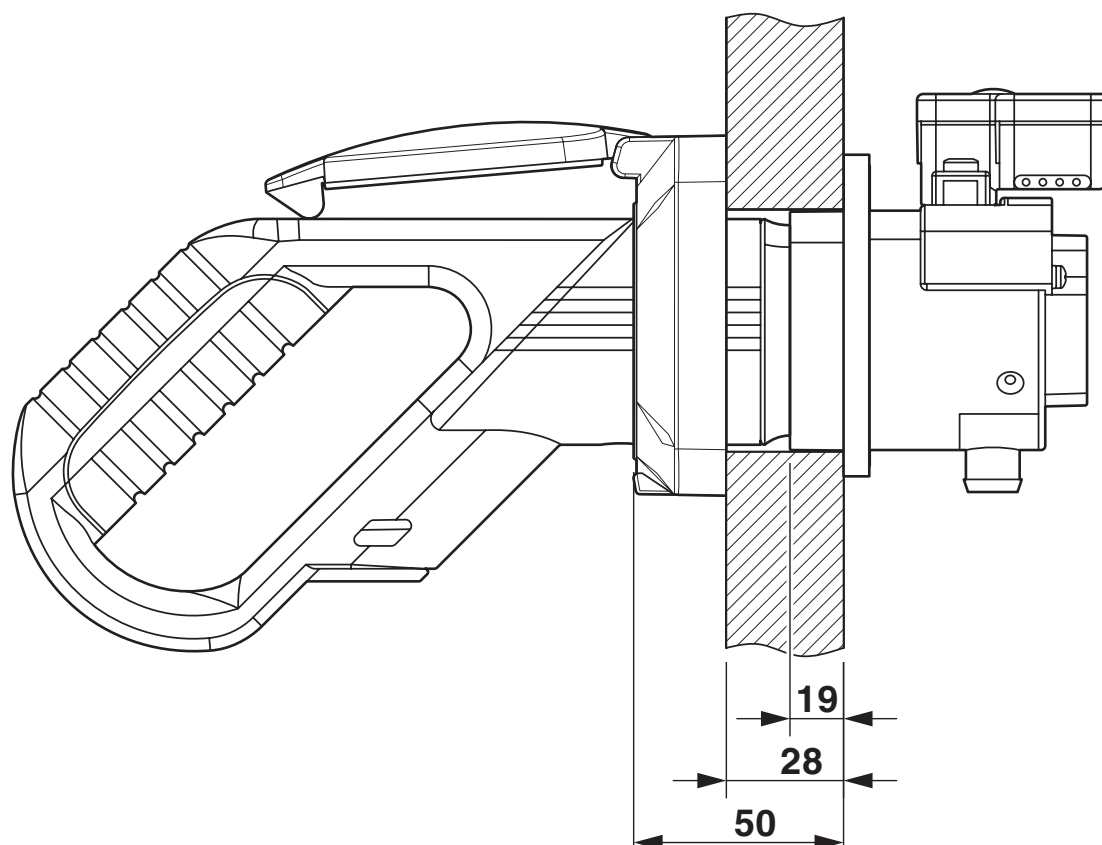

Panel thickness for rear mounting (max. 50 mm, with Phoenix Contact protective cover, max. 22 mm)

EV-T2M3SE24-3AC32A-0,5M6,0E11 - Infrastructure charging socket



1409681

<https://www.phoenixcontact.com/us/products/1409681>

Schematic diagram

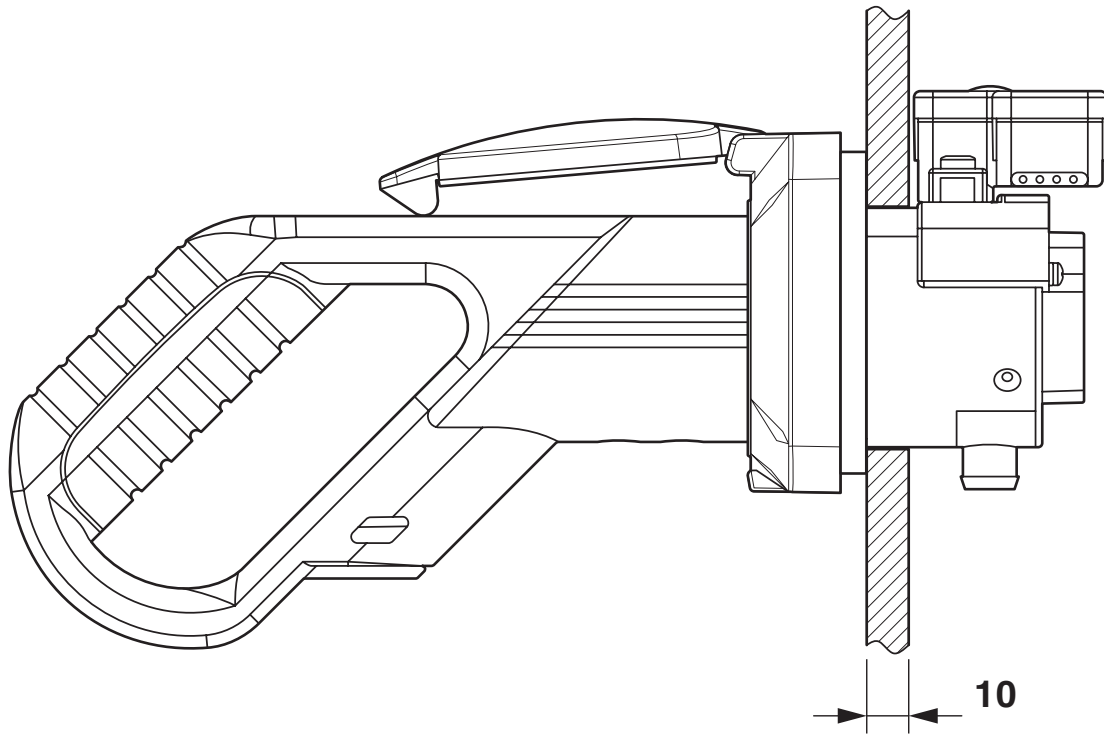

Panel thickness for front mounting (in mm)

EV-T2M3SE24-3AC32A-0,5M6,0E11 - Infrastructure charging socket

1409681

<https://www.phoenixcontact.com/us/products/1409681>

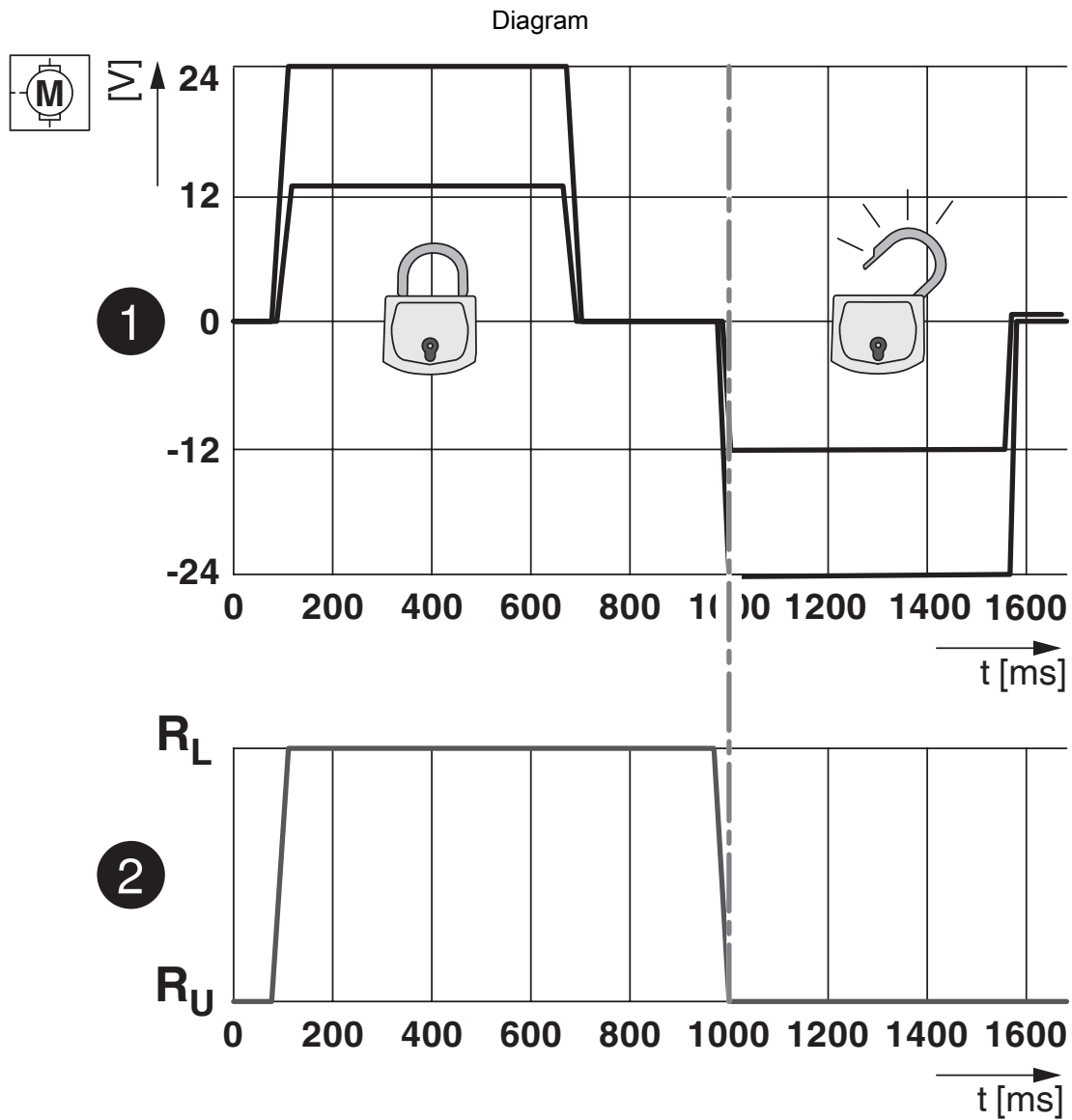

Locking states of the locking actuator

EV-T2M3SE24-3AC32A-0,5M6,0E11 - Infrastructure charging socket

1409681

<https://www.phoenixcontact.com/us/products/1409681>

Block diagram

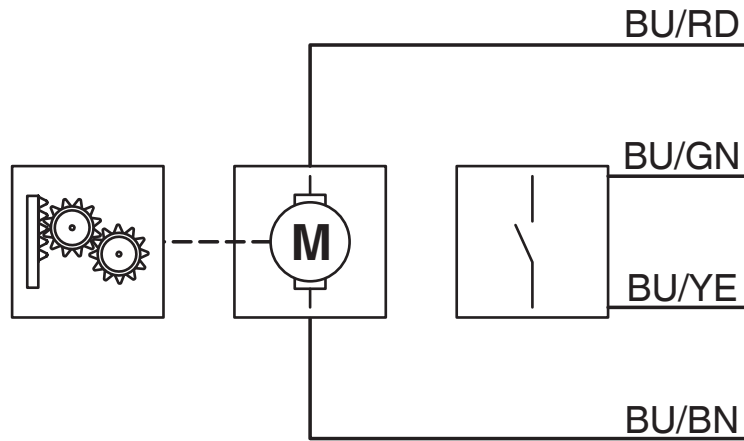

Block diagram of the locking actuator

EV-T2M3SE24-3AC32A-0,5M6,0E11 - Infrastructure charging socket



1409681

<https://www.phoenixcontact.com/us/products/1409681>

Classifications

UNSPSC

UNSPSC 21.0	39121522
-------------	----------

EV-T2M3SE24-3AC32A-0,5M6,0E11 - Infrastructure charging socket



1409681

<https://www.phoenixcontact.com/us/products/1409681>

Environmental product compliance

EU RoHS

Fulfills EU RoHS substance requirements	Yes
Exemption	6(c)

China RoHS

Environment friendly use period (EFUP)	EFUP-10
	An article-related China RoHS declaration table can be found in the download area for the respective article under "Manufacturer declaration". For all articles with EFUP-E, no China RoHS declaration table issued and required.

EU REACH SVHC

REACH candidate substance (CAS No.)	Lead(CAS: 7439-92-1)
-------------------------------------	----------------------

Phoenix Contact 2026 © - all rights reserved
<https://www.phoenixcontact.com>

Phoenix Contact USA
586 Fulling Mill Road
Middletown, PA 17057, United States
(+717) 944-1300
info@phoenixcon.com